



techsystem

automatyka klimatyzacja wentylacja

▸ zapoznaj się z naszą ofertą

HT-1000 Series

Room Humidity Sensors

The Johnson Controls HT-1000 series room humidity sensors provide active sensing of relative humidity and, on specific models, also active/passive sensing of temperature in HVAC applications.

It features a polymer capacitance humidity sensing element and provides within either $\pm 2\%$ or $\pm 3\%$ accuracy a voltage output signal proportional 0 to 100 % relative humidity.

The HT-1000 series room humidity sensors are designed for use with Johnson Controls System 91 and Facility Explorer controllers or for other systems having compatible input and output voltages.



HT-1xxx-UR
Room Humidity Sensor

- **Humidity output available with 2% accuracy**
More accurate humidity control and energy savings.
- **Modern and attractive cover with mounting base**
Blends in with room decor. Easy installation.
- **All models with wide supply voltage range**
Suitable to a large range of controllers.
- **Senses over the entire range of 0 to 100% RH (non condensing)**
More accurate humidity control.
- **Transmitter can resist many hostile environments**
Suitable for a wide range of applications.
- **Temperature measurement options**
Eliminates the need for a separate temperature sensors.
- **Polymer humidity sensing element is integrated onto a chip**
Provides stability, repeatability and linear response.

Humidity output curve

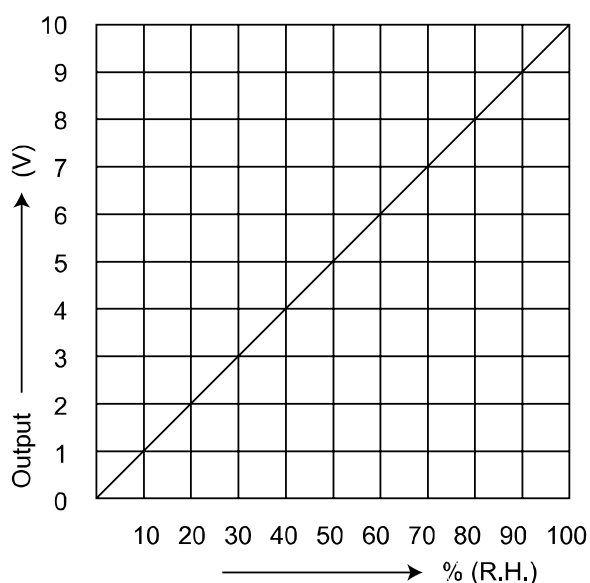

Humidity output voltage curve

Temperature vs. resistance table for HT-1000 with passive temperature output

Temperature (°C)	Resistance (Ω)	
	Pt1000	NTC K2
0	1000	7352.8
5	1020	5717.8
10	1039	4481.5
15	1058	3537.9
20	1078	2812.8
25	1097	2252.0
30	1117	1814.4
35	1136	1470.6
40	1155	1199.6
45	1175	---
50	1194	---
55	1213	---
60	1232	---

Installation

The HT-1000 room humidity sensors are designed for wall mounting in the room to be controlled. It should be placed where the temperature is representative of the general room conditions. Cold or warm air draughts, radiant heat and direct sunlight should be avoided.

The installation of electrical wiring must conform to local codes and should be carried out by authorized personnel only. Users should ensure that all Johnson Controls products are used safely and without risk to health or property.

The HT-1000 series room humidity sensors are intended to provide input to equipment under normal operating conditions. Where failure or malfunction of an HT-1000 series room humidity sensors could lead to an abnormal operating condition that could cause personal injury or damage to the equipment or other property, other devices (limit or safety controls) or systems (alarm or supervisory) intended to warn of, or protect against, failure or malfunction of the HT-1000 sensors must be incorporated into and maintained as part of the control system.

To avoid damage to the HT-1000 sensors, do not mount the unit in a location where high concentrations of corrosive vapours are present.

A short description of the effects on sensing element due to exposure to chemicals' vapour, aggressive substances and environment is reported in the table below.

Chemical	Effect
Ethilic alcohol	Unrecoverable damage after long exposure
Oxygen peroxide	No effect
Silicone	Wrong output during exposure; recovered when not exposed
Ammonia	Unrecoverable damage also after short exposure
Cigarette smoke	Output shift during exposure, recovered when not exposed
Cheese	Output shift during exposure, recovered when not exposed
Swimming pool water	No sensible effect (minimum shift during exposure)
Sodium chloride	No effect
Chlorexidine + cetrimide 1%	No sensible effect (minimum shift during exposure)
Chlorexidine + cetrimide 3.3%	Unrecoverable damage after long exposure
Glutaraldehyde 2%	Output shift during and after exposure
Sodium hypochlorite	No sensible effect (minimum shift during exposure)
Quaternary ammonium salt	Unrecoverable damage after long exposure

Mounting

Remove the base of the module from the cover by inserting the point of the special TM tool (Ordering Code TM-9100-8900) into the small hole at the center top of the cover. While pressing down gently, prise the base away from the cover. As the two parts separate, remove the tool and continue to pull the cover away from the base until the cover is free.

Mount the module base on the wall to cover the electrical outlet and secure with at least two screws. To reassemble the room command module, place the cover over the lower edge of the base and push the upper part of the cover until it "clicks" firmly in place.

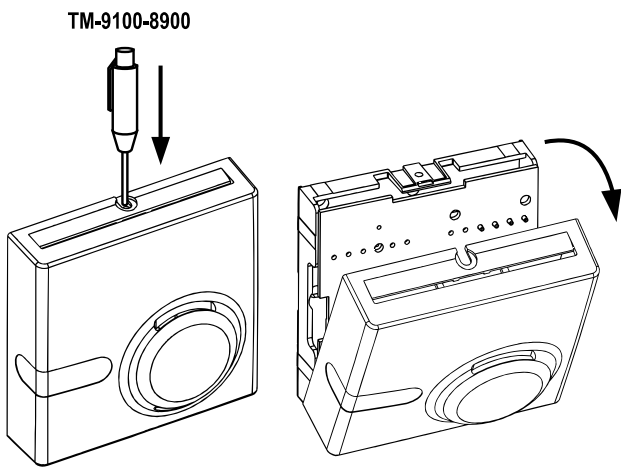

Surface Mounting with Mounting Kit (TM-1100-8931)

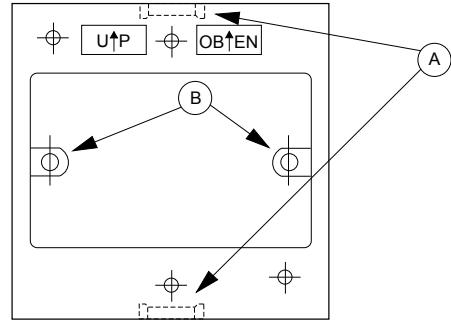

1. Remove one of the notches (A) with a suitable tool.
2. Mark the position of the holes (B) on the wall and drill holes 5 mm in diameter. Insert plastic plugs into holes.

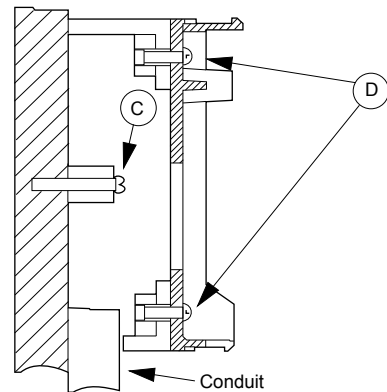

3. Position and fix the mounting base to the wall using the two long screws (C) provided in the kit.
4. Fix the base of the HT-1000 to the mounting base using the two short screws (D) provided in the kit.

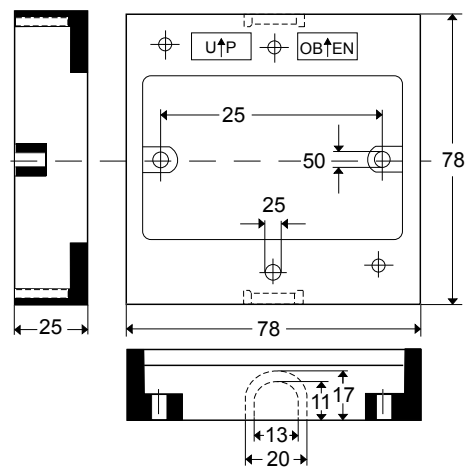

Wirings

Before connecting or disconnecting any wires, ensure that all power supplies have been switched off and all wires are potential-free to prevent equipment damage and avoid electrical shock.

Terminations are made on the terminal blocks in the base of the module, which accept up to 1.5 mm² wires.

Follow the wiring diagrams shown in the figures below. All wiring to the module is at extra low (safe) voltage and must be separated from power line voltage wiring. Do not run wiring close to transformers or high frequency generating equipment.

Complete and verify all wiring connections before applying power to the controller to which the module is connected.

Dimensions (in mm)

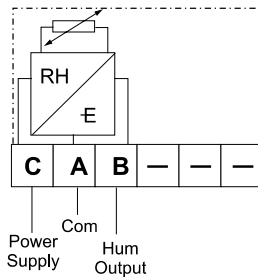
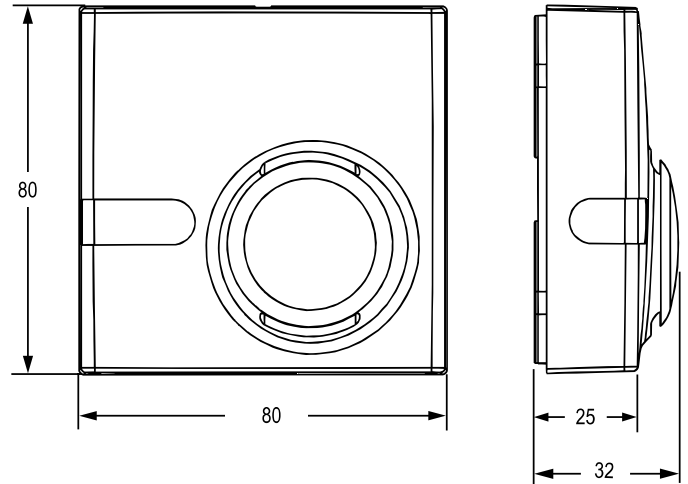

**No Temperature Output
(HT-1300-UR)**

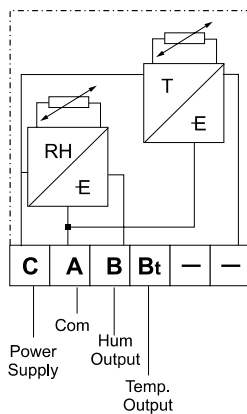

**0...10 V DC Temperature Output
(HT-1201-UR and HT-1301-UR)**

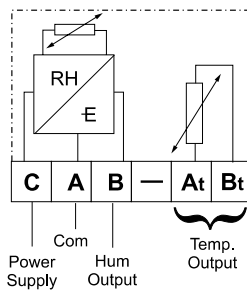

**NTC K2 or Pt1000
Passive Temperature Output
(HT-1303-UR and HT-1306-UR)**

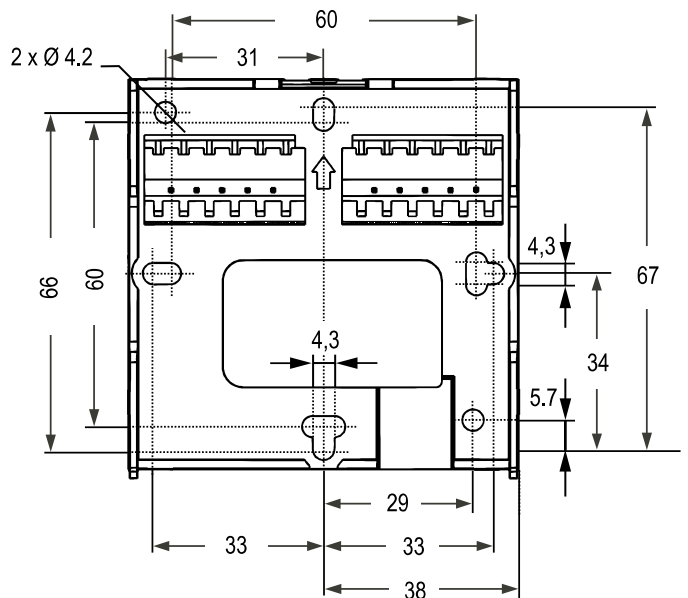

Dimensions base plate

Ordering Code

Codes	Humidity Output	Accuracy	Temperature Output
HT-1201-UR	0...10 V DC	2%	0...10 V DC
HT-1300-UR		3%	---
HT-1301-UR			0...10 V DC
HT-1303-UR			NTC K2
HT-1306-UR			Pt1000

Accessories

Codes	Description
TM-1100-8931	Surface Mounting Base
TM-9100-8900	Special Tool to Open the module

Technical Specification

Products	HT-1xxx-UR Series Humidity Sensor
Power supply	12 to 30 V DC or 24 V AC \pm 15% at 50/60 Hz
Output load	5 k Ω min (2 mA max)
Relative humidity range	0...100% RH
Humidity output signal	0...10 V DC
Humidity sensing accuracy	
	HT-1201-UR \pm 4% RH for 0% to 20% RH
	\pm 2% RH for 20% to 80% RH
	\pm 4% RH for 80% to 100% RH
	HT-130x-UR \pm 6% RH for 0% to 10% RH
	\pm 3% RH for 10% to 90% RH
	\pm 6% RH for 90% to 100% RH
Temperature Sensing Outputs (if present)	
	HT-1201-UR and HT-1301-UR 0...10 V DC (range 0...40 °C, accuracy \pm 0.5°C of full range)
	HT-1303-UR NTC thermistor 2.2K: 2252 Ω @ 25 °C (\pm 0.2°C)
	HT-1306-UR Pt1000 Class A (EN 60751)
Hysteresis	\pm 0.8% of maximum span
Linearity	\pm 0.5% RH typical
Repeatability	\pm 0.5% RH
Enclosure Protection Class	IP30 (EN 60529)
Electrical Connections	Terminal block connectors accepting 1 x 1.5 mm ² of 1 x 14 AWG or 2 x 18 AWG wires
Ambient Operating Condition	0 to +50 °C (non condensing)
Ambient Storage Condition	-20° to +70 °C (non condensing)
Enclosure Material	Self-extinguishing UL94HB ABS+PC
Weight	0.15 kg.
Dimensions (H x W x D)	80 x 80 x 32 mm
CE Compliance	EMC Directive: 89/336 EEC (EN 61000-6-3, EN 61000-6-2)

The performance specifications are nominal and conform to acceptable industry standards. For applications at conditions beyond these specifications, consult the local Johnson Controls office or representative. Johnson Controls shall not be liable for damages resulting from misapplication or misuse of its products.

