



# techsystem

automatyka klimatyzacja wentylacja

▸ zapoznaj się z naszą ofertą

## VA1000 Electric Actuator with Spring Return and Non-Spring Return Function

### Introduction

The VA1000 2500N thrust and 2000N thrust (spring return) valve-actuators are used to control valves in HVAC systems. This new actuator is self-adjusting and therefore has a greatly reduced installation and commissioning time. They are of modular construction so that for instance, the required type of control signal is achieved simply by fitting a module with the required function in-situ.

Valves intended for use with the VA1000 are the Johnson Controls VG9000 PN6 & PN10 flanged valves and the VG8000 / VG8300 series PN16 & PN25 flanged valves.

All actuators are self adjusting, have a manual operation capability and a maximum stroke of 49mm.



VA1000 Actuator with VG8000N mixing valve

### Features and Benefits

<input type="checkbox"/> <b>Automatic stem coupling</b>	Provides quick and easy mounting of the actuator to valves. Cuts installation costs
<input type="checkbox"/> <b>Actuator fixed to valve with one ring nut</b>	Fast and secure attachment to valve
<input type="checkbox"/> <b>Self adjusting, automatic stroke adjustment, calibrated pressure control at the end positions</b>	No input signal change necessary for calibration, considerable time saved
<input type="checkbox"/> <b>Additional modules for 230V, 2 aux. switches, feedback potentiometer and split range unit available</b>	One basic standard actuator, small storage space and quick availability
<input type="checkbox"/> <b>IP66</b>	High protection class, greater area of application
<input type="checkbox"/> <b>Selectable characteristic curve</b>	Simpler solving of control tasks in-situ
<input type="checkbox"/> <b>Selectable running time</b>	Possible through DIP switch setting in-situ

## Ordering data

### 24V Actuators

VA1125-GGA-1	2500N; Non-spring return
VA1220-GGA-1	2000N; Spring return retracts
VA1420-GGA-1	2000N; Spring return extends

### Accessory modules for in-situ installation

VA1000-M230	AC 230V module
VA1000-P2	2k $\Omega$ feedback potentiometer
VA1000-S2	2 SPDT aux. switches
VA1000-SRU	Split range unit module for proportional actuators only
VA1000-EP	Extension kit for applications with temperatures greater than 140°C up to 200°C
111 6348 011	Cable adaptor M20x1.5
111 6349 011	Cable adaptor M16x1.5

**Note:** Either feedback potentiometer or aux. switches can be fitted not both.

## Ordering Procedure

The valves and actuators can be ordered separately or factory mounted. When factory mounted, please add “+M” to the order code for the actuator.

### For example:

For a 2-way valve, DN 65,  $k_{VS}$  63, PN 16 plus 24 V 2500N actuator, order:

Item 1 **VG82G1S1N** (valve body)  
 Item 2 **VA1125-GGA-1** (actuator)

Alternatively, if actuator is requested to be factory mounted, order:

Item 1 **VG82G1S1N** (valve body)  
 Item 2 **VA1125-GGA-1+M** (actuator)

## Actuator - Valve combinations

The VA1000 spring return and non-spring return electric actuators are intended for use in conjunction with the VG9000 and VG8000 valve series. The ordering data for these valve bodies are as follows:

- **VG9000 series** PN6 (K) and PN10 (L)

2-way PDTC      **DN 65...100**  
 3-way mixing      **DN 65...100**

- **VG8000V series** PN16 flanged valves

2-way PDTC      **DN 15...150**  
 3-way mixing      **DN 15...150**

- **VG8000N series** PN16 flanged valves

2-way PDTC      \*) **DN 15...150**  
 3-way mixing      \*) **DN 15...150**  
 3-way diverting \*) **DN 15...150**

\*) Here DN 15  $k_{VS}$  starts at 2.5

- **VG8000H series** PN25 flanged valves

2-way PDTC      \*) **DN 15...150  $k_{VS}$**   
 3-way mixing      \*) **DN 15...150  $k_{VS}$**   
 3-way diverting \*) **DN 15...150  $k_{VS}$**

\*) Here DN 15  $k_{VS}$  starts at 2.5

- **VG8300N + H series** (PN16 and PN25 pressure balanced flanged valves)

2-way PDTC      **DN 40...150  $k_{VS}$**

Please refer to the relevant flanged valve product bulletins for complete ordering information.

For use with non-Johnson Controls valves please contact Johnson Controls.

## Actuator – valve designation, close-off pressures

Model	DN	k <sub>vs</sub> (m <sup>3</sup> /h)	Close-off pressure (kPa)	
			Non-Spring return actuator	Spring return actuator
			VA1125-GGA-1	VA1220-GGA-1 / VA1420-GGA-1
<b>VG9000 PN6 Heating valve</b>				
VG9xGxS1K	65	63	620	470
VG9xHxS1K	80	100	400	300
VG9xJxS1K	100	160	240	180
<b>VG9000 PN10 Heating valve</b>				
VG9xGxS1L	65	63	620	470
VG9xHxS1L	80	100	400	300
VG9xJxS1L	100	160	240	180
<b>VG8000V PN16 Heating valve</b>				
VG8xAxV1N	15	2.5/4	1600	1600
VG8xBxV1N	20	6.3	1600	1600
VG8xCxV1N	25	10	1600	1600
VG8xDxV1N	32	16	1600	1600
VG8xExV1N	40	25	1600	1600
VG8xFxV1N	50	40	1080	800
VG8xGxV1N	65	63	830	620
VG8xHxV1N	80	100	390	280
VG8xJxV1N	100	160	230	160
VG8xKxV1N	125	250	140	90
VG8xLxV1N	150	350	75	40

## Actuator – valve designation, close-off pressures (continued)

Model	DN	kvs (m <sup>3</sup> /h)	Close-off pressure (kPa)	
			Non-Spring return actuator	Spring return actuator
			VA1125-GGA-1	VA1220-GGA-1 / VA1420-GGA-1
<b>VG8000N PN16 System valves</b>				
VG8xAxS1N	15	2.5 – 4	1600	1600
VG8xBxS1N	20	6.3/4	1600	1600
VG8xCxS1N	25	10/6.3	1600	1600
VG8xDxS1N	32	16/10	1600	1600
VG8xExS1N	40	25/16	1600	1600
VG8xFxS1N	50	40/25	1080	800
VG8xGxS1N	65	63/40	830	620
VG8xHxS1N	80	100/63	390	280
VG8xJxS1N	100	160/100	230	160
VG8xKxS1N	125	250/160	140	90
VG8xLxS1N	150	350/250	75	40
<b>VG8000H PN25 System valves</b>				
VG8xAxS1H	15	2.5 – 4	2500	2500
VG8xBxS1H	20	6.3/4	2500	2500
VG8xCxS1H	25	10/6.3	2500	2500
VG8xDxS1H	32	16/10	2500	2500
VG8xExS1H	40	25/16	2000	1550
VG8xFxS1H	50	40/25	1020	750
VG8xGxS1H	65	63/40	790	580
VG8xHxS1H	80	100/63	370	260
VG8xJxS1H	100	160/100	210	140
VG8xKxS1H	125	250/160	120	80
VG8xLxS1H	150	350/250	70	40
<b>VG8300N PN16 pressure balanced valves</b>				
VG83ExS1N	40	25/16	1600	1600
VG83FxS1N	50	40/25	1600	1600
VG83GxS1N	65	63/40	1600	1600
VG83HxS1N	80	100/63	1600	1600
VG83JxS1N	100	160/100	1600	1500
VG83KxS1N	125	250/160	1500	1400
VG83LxS1N	150	350/250	1400	1000
<b>VG8300H PN25 pressure balanced valves</b>				
VG83ExS1H	40	25/16	2500	2500
VG83FxS1H	50	40/25	2500	2500
VG83GxS1H	65	63/40	2500	2500
VG83HxS1H	80	100/63	2500	2500
VG83JxS1H	100	160/100	2500	2000
VG83KxS1H	125	250/160	1900	1400
VG83LxS1H	150	350/250	1500	1000

# A djustments

The actuator characteristic curve (proportional) and the actuator running time with regard to the application can be re-set prior to installation. The factory setting is a linear characteristic curve and 6s/mm running time.

Running time per mm	Switch configuration	Running time for 14 mm stroke	Running time for 25 mm stroke	Running time for 42 mm stroke
2s		28s ± 1	50s ± 1	84s ± 2
4s		56s ± 2	100s ± 2	168s ± 4
6s	 	84s ± 4	150s ± 4	252s ± 8

See actuator Service and Data Sheet: SDS 111 6340 010 & SDS 111 6341 010

At this point, if required, additional modules can be fitted to the actuator and the cable adapters screwed in: 1xM20 x 1.5 and 1xM16 x 1.5 as delivered.

## Mounting instructions

When mounting the actuator on a valve, please follow the instructions below:

- Valve sizes DN 15 to DN 40 actuator flanges are to be loosened, turned 90° and re-tightened. The actuator is then set on to the valve and fixed into position using the ring nut provided. The automatic coupling can now be put into the open position if not already so.
- It is recommended that the valves be mounted in the upright position in a conveniently accessible location.

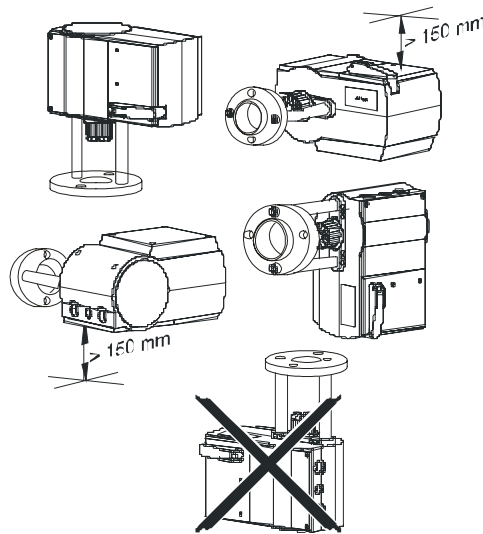

- The actuator must not be covered with insulating material
- Sufficient clearance must be allowed for actuator removal (refer to the dimension drawings)
- The valve must be fitted so that the plug seats against the flow as indicated by the arrow(s) on the valve body.
- All work is to be carried out by qualified personnel in accordance with the relevant **Service and Data Information** listed below:

Order numbers	Device	Service and Data Sheets
VA1125-GGA-1	<b>Non-spring-return actuator</b>	<b>SDS 111 6340 010</b>
VA1220-GGA-1	<b>Spring-return actuator</b>	<b>SDS 111 6341 010</b>
VA1420-GGA-1		<b>SDS 111 6341 010</b>
	<b>Modules</b>	
VA1000-M230	AC 230V module	<b>SDS 111 6342 010</b>
VA1000-P2	2kΩ feedback potentiometer	<b>SDS 111 6343 010</b>
VA1000-S2	2 SPDT aux. switches	<b>SDS 111 6344 010</b>
VA1000-SRU	Split range unit module for proportional actuators only	<b>SDS 111 6345 010</b>
VA1000-EP	Extension kit for applications with temperatures greater than 140°C up to 200°C	<b>SDS 111 6346 010</b>

# Wiring instructions

- All wiring must be in accordance with local regulations and national electrical codes, and should be carried out by authorised personnel only.
- Make sure that the line power supply is in accordance with the power supply specified on the device.

## WARNING

### Shock Hazard

Disconnect the power supply before wiring connections are made to avoid personal injury.

### Equipment Damage Hazard

Make and check all wiring connections before applying power to the system. Short circuited or improperly connected wires may result in permanent damage to the unit

#### ◆ VA1125-GGA-1 Non-Spring-Return

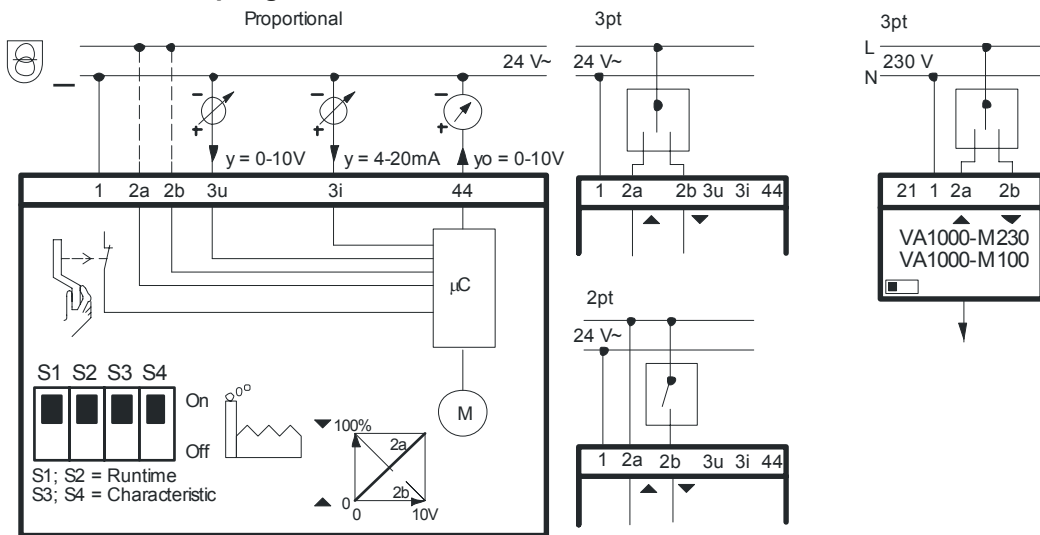

#### ◆ VA1220-GGA-1 and VA1420-GGA-1 Spring-Return

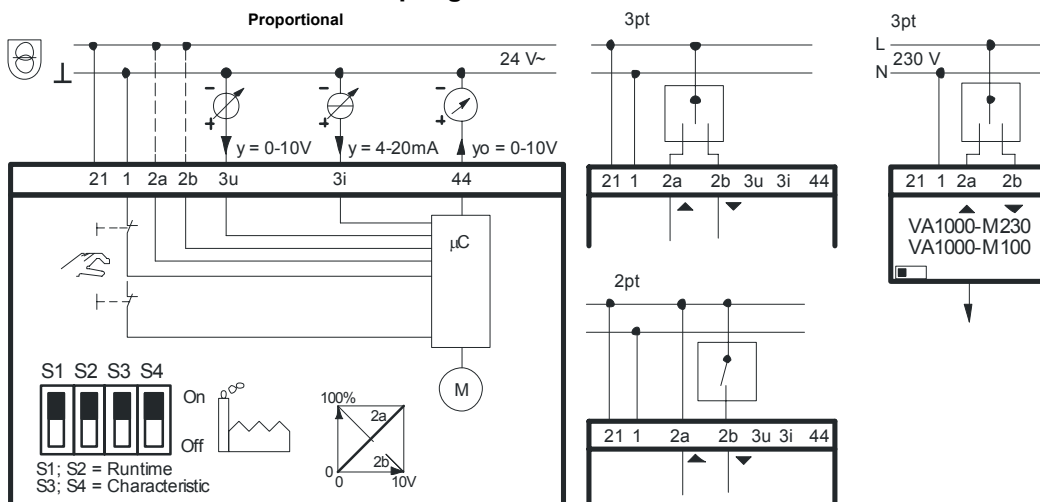

◆ VA1000-SRU (for 24 V proportional only)

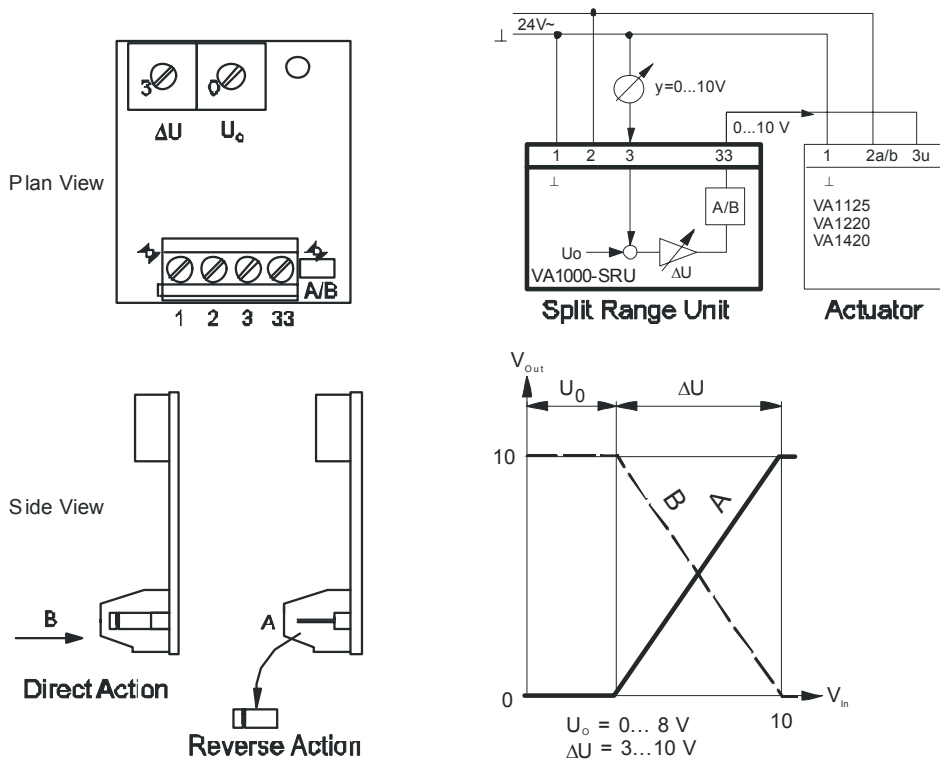

◆ VA1000-S2 Auxiliary Switches

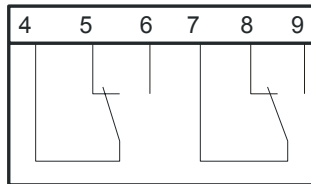

◆ VA1000-P2 Potentiometer

s (mm)	Connection			Connection terminal
40	10	11a	12a	top
20	10	11b/c	12c	down
14	10	11b/c	12b	top
		100%	0%	

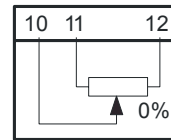

# Dimensions in mm

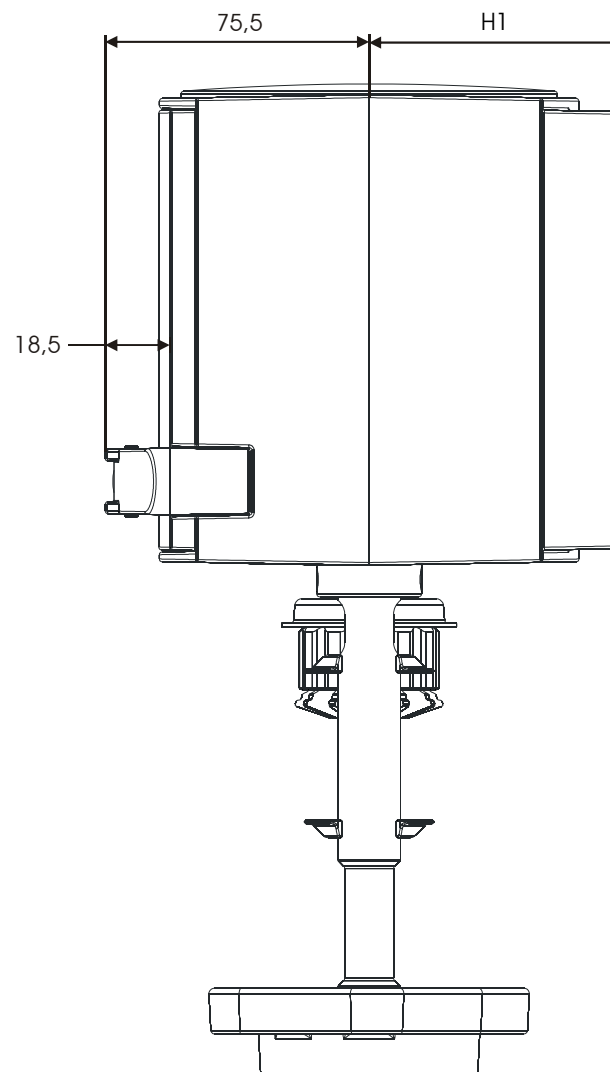
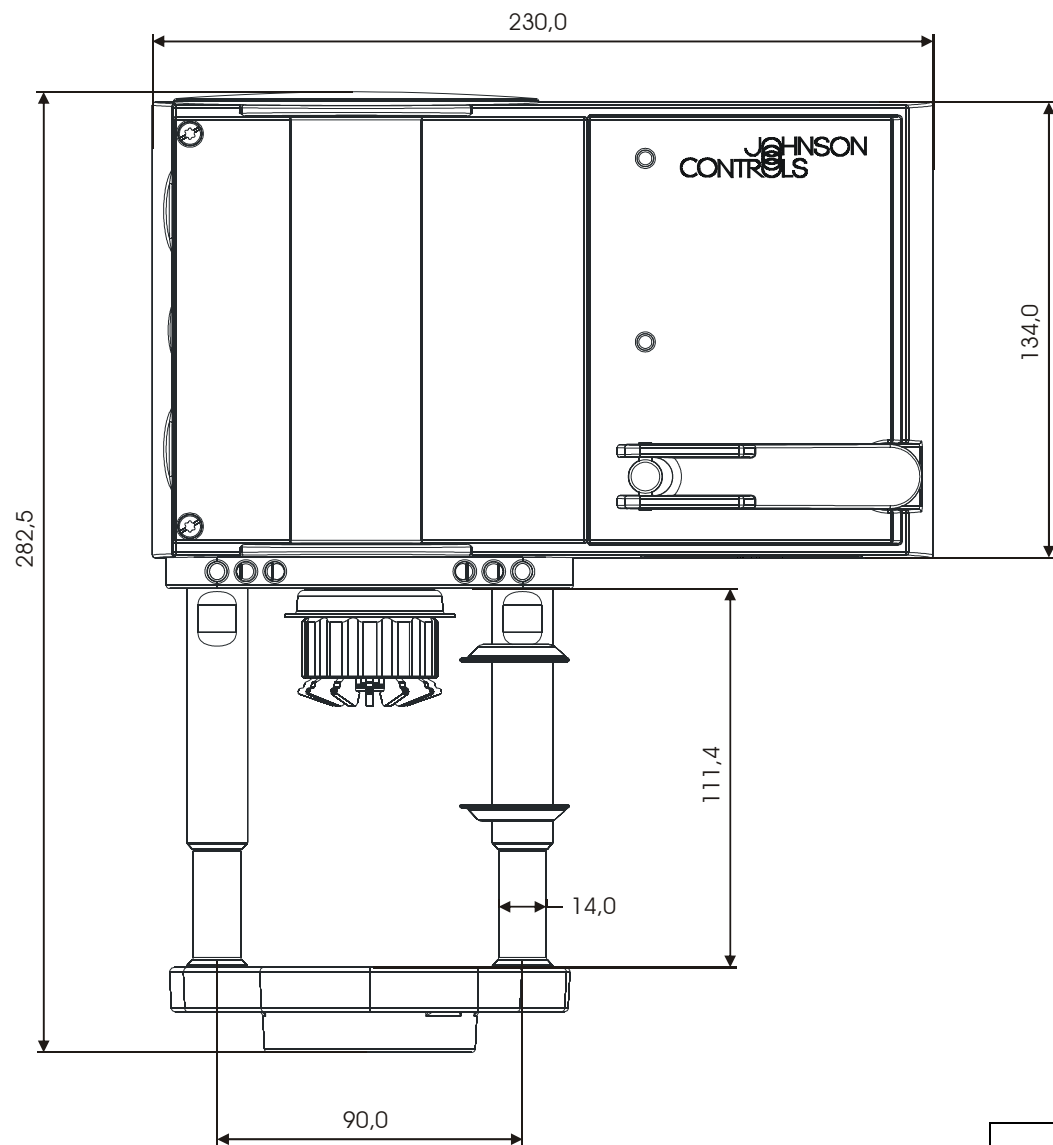

	<b>VA1125-GGA-1</b>	<b>VA1220-GGA-1 &amp; VA1420-GGA-1</b>
<b>H1</b>	60 mm	73 mm

## Specifications

Actuator models	VA1125-GGA-1 Non-Spring-Return	VA1220-GGA-1 Spring-Return retracts VA1420-GGA-1 Spring-Return extends
<b>Associated valve series and body sizes</b>	VG9000K PN6, DN65...DN100,	Two way & mixing valves.
	VG9000L PN10, DN65...DN100,	Two way & mixing valves.
	VG8000V PN16, DN15...DN150,	Two way & mixing valves.
	*)VG8000N PN16, DN15...DN150	Two-way, mixing & diverting valves.
	*)VG8000H PN25, DN15...DN150	Two-way, mixing & diverting valves.
	VG8300N PN16, DN40...DN150	Two way pressure balanced valves.
	VG8300H PN25, DN40...DN150	Two way pressure balanced valves.
<b>Control</b>	2-point, 3-point, Proportional, 0...10 V DC, 4...20mA	
<b>Impedance</b>	100 kΩ @ DC 0...10 V - 50Ω @ 4...20mA	
<b>Hand crank</b>	Standard	
<b>Supply voltage and frequency</b>	AC 24 V ±20%, (50/60 Hz), DC 24 V ±15% Module AC 230 V ±15%, (50/60 Hz)	
<b>Power consumption (Idling)</b>	20.5 VA (1.5 VA)	17 VA (9.3 VA)
<b>Nominal Thrust</b>	2500 N	2000 N
<b>Nominal stroke</b>	49 mm	
<b>Nominal running speed</b>	2 / 4 / 6 s/mm – Factory setting = 6 s/mm	
<b>Enclosure Protection / Class</b>	IP 66 / III as per EN60730	
<b>Spring-return running time</b>	15s for 13mm valve stroke; less than 35s for 42mm valve stroke	
<b>Operation</b>	-10...+55 °C	
<b>Storage</b>	-30...+80 °C	
	R.H. < 95 %, non condensing	
<b>Electrical Connection</b>	6 Terminals max. 2.5mm <sup>2</sup>	7 Terminals max. 2.5mm <sup>2</sup>
<b>Cable adapter</b>	2xM20 x 1.5 and 1xM16 x 1.5 (1 of each included in delivery)	
<b>Noise level</b>	60 dB (A) @ 1 meter	65 dB (A) @ 1 meter
<b>Life time</b>	Tested for 100 000 full cycles	Tested for 40 000 full cycles
<b>Net weight</b>	4.2 kg	5.7 kg
<b>Approvals</b>	European Directives: EMC (89 / 336 / EEC) LVD (73 / 23 / EEC) EN6100-6-1...4 EN60730-1 EN60730-2-14	

\*) Here DN 15 k<sub>vs</sub> starts at 2.5.

The performance specifications are nominal and conform to acceptable industry standards. For application at conditions beyond these specifications, consult the local Johnson Controls office. Johnson Controls, Inc. is not liable for damages resulting from misapplication or misuse of its products.



**Johnson Controls International, Inc.**

Headquarters:  
European Distribution Centre:  
European Factories:  
Branch Offices

Milwaukee, Wisconsin, USA  
Westendhof 3, D-45143 Essen, Germany  
Essen (Germany) and Lomagna (Italy)  
Principal European Cities.