



techsystem

automatyka klimatyzacja wentylacja

▸ zapoznaj się z naszą ofertą

VA-7150 Electric Valve Actuator

Introduction

The VA-7150 series synchronous motor driven actuator provides floating or proportional control of valves with up to 19mm stroke in heating, ventilation and air conditioning applications.

This compact, non-spring return actuator has 500 N nominal thrust and responds to a variety of input signals.

The VA-7150 series can be easily installed on site or ordered pre-fitted to VG7000, VGS800W1N and VBF flanged valve series in accordance with the specified maximum close-off pressure ratings (see pertinent valve bulletins)



**VA-7150 valve-actuator with VBF flanged valve
and VG7010 threaded valve**

Features and Benefits

<input type="checkbox"/> 500 N force output in a compact unit	Covers a wide range of applications with one actuator
<input type="checkbox"/> Magnetic clutch	Provides constant output force for closeoff of valves, and protects motor in stall conditions
<input type="checkbox"/> Unique Yoke Design	Easy in-situ fitting reduces installation and stroke adjustment time
<input type="checkbox"/> Coupler for simple actuator attachment to flanged valves	Quick and easy fitting of the actuator to valves with slotted stem
<input type="checkbox"/> Positioner with adjustable starting point and span, reverse and direct action modes	Easy setup and installation and allows sequence control
<input type="checkbox"/> “Signal fail” safe position	Valve safety position after control signal failure, the safety position, up / down, is selectable in-situ

Ordering data

VA-715	-	0	
Voltage supply			
1	24 VAC, 50 / 60 Hz		
3	230 VAC, 50 / 60 Hz (only for floating models)		
Valve type			
10	VG7000, VG7010 with threaded stem connection		
82	VBF PN6 and PN10 flanged valves and VGS800W1N male threaded valves		
Control Type			
0	Floating		
2	Proportional 0...10V		

Note: floating models with 2kΩ feedback and auxiliary switches are available on request

Ordering procedure

The actuator can be ordered as a separate unit or a factory fitted valve-actuator combination. Should the latter be required, please just add “+M” to the end of the actuator ordering code.

For example:

Item 1 **VG7203AT** (valve body)

Item 2 **VA-7152-1001** (actuator)

Alternatively, to order a factory fitted combination.

Item 1 **VG7203AT** (valve body)

Item 2 **VA-7152-1001+M** (actuator)

Repair Information

Do not attempt local repair. For a replacement actuator, contact the nearest Johnson Controls representative.

Actuator / valve combinations

The VA-7150 can be combined with the following valve ranges:

● VG7000 and VG7010 series

Female and male threaded valves

VG7 T all body types DN 15...50

● VGS800W1N Mixing + mod kit = 2-way PDT0

VGS8 W1N DN 15...50

● VBF series, PN6 and PN10

VBF 4-5200 Two-way PDT0 DN 15...50

VBF 8-5200 Mixing DN 15...40

For complete ordering information, please refer to the relevant product bulletin

Operation

The VA-715x Series actuators use a reversible synchronous motor and magnetic clutch to accurately position the valve. The combination can reliably generate 500 N of force in either direction.

When the signal is removed the shut-off force is maintained until the controller sends signal for actuator stem to retract.

The magnetic clutch maintains a constant load at the end of travel, which ensures tight valve shutoff and compensates for seat wear.

Floating Control VA-7150

A controller provides 24 VAC to the “extend stem”, “retract stem” and common terminals depending upon the required valve position. The signal causes the motor to rotate in the desired direction. The gear train and drive screw extends or retracts the stem.

When the controller signal ceases, the valve stem position is maintained until the next control signal is received.

Note: In incremental application, there is no direct correlation between valve position and controller output (0 to 100 %). If correlation is important, use proportional control or actuators that provide position feedback.

Proportional Control VA-7152

The VA-7152 provides a proportional stroke in relation to the input control signal of 0 to 10, 0 to 5, or 5 to 10 VDC jumper selectable input control signals. It also features stroke selection and Direct Acting (DA) or Reverse Acting (RA) jumpers.

An electronic controller provides the proportional input signal to the VA-7152. The signal is compared to the actual valve position via internal feedback potentiometer.

The internal circuit activates the motor, which rotates in the desired direction. The gear train and drive screw move the valve stem to the position called for by the input signal.

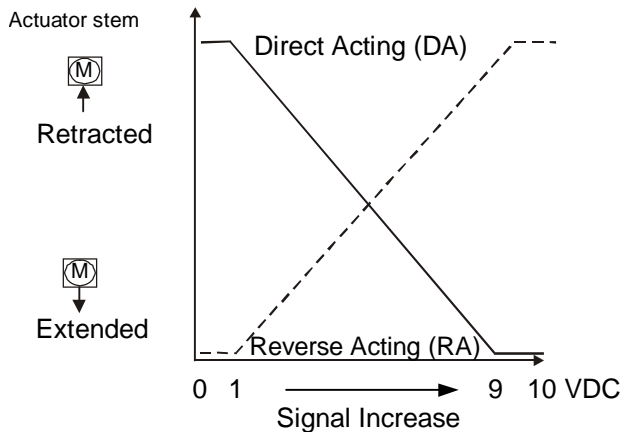

“Signal Fail” safe position

A signal failure on proportional models will cause the actuator to automatically move the stem to a (via jumper) pre-selected position (completely extended or completely retracted).

Mounting instructions

When mounting the actuator on a valve, please follow the instructions below:

- It is recommended that the valves be mounted upright in an easily accessible location.

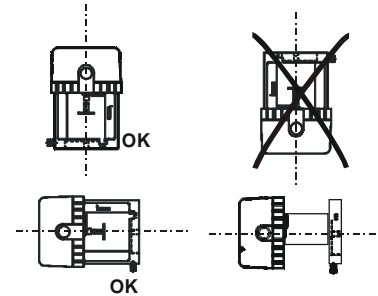

- The actuator must be protected against dripping water, which could enter the housing and damage the mechanism or motor.
- Do not cover with insulating material.
- Sufficient clearance must be allowed for actuator removal (refer to the “Dimension” drawings).
- The valve must be installed so that the plug seats against the flow, as indicated by the arrows on the valve.

Wiring instructions

- All wiring must be in accordance with local regulations and national electrical codes and should be carried out by authorised personnel only.
- Make sure that the line power supply is in accordance with the power supply specified on the device.

WARNING

Shock Hazard

Disconnect the power supply before wiring connections are made to prevent personal injury.

Equipment Damage Hazard

Make and check all wiring connections before applying power to the system. Short circuited or improperly connected wires may result in permanent damage to the unit.

Wiring Diagrams:

Floating models 24 VAC

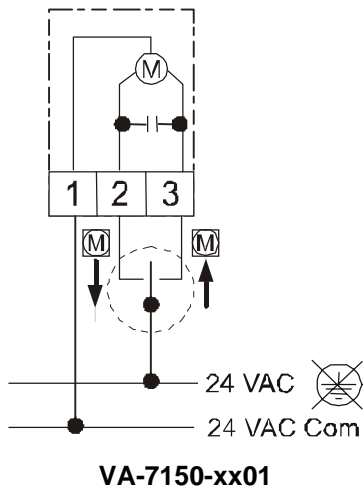

Proportional model 24 VAC

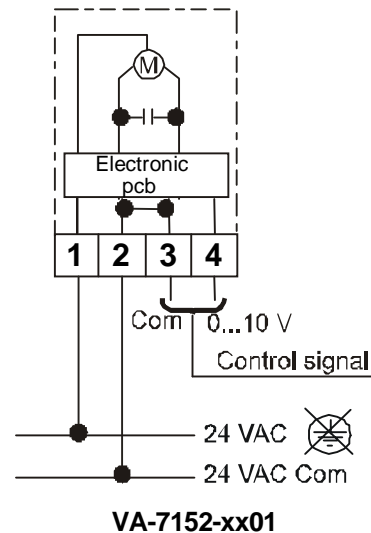

Floating models 230VAC

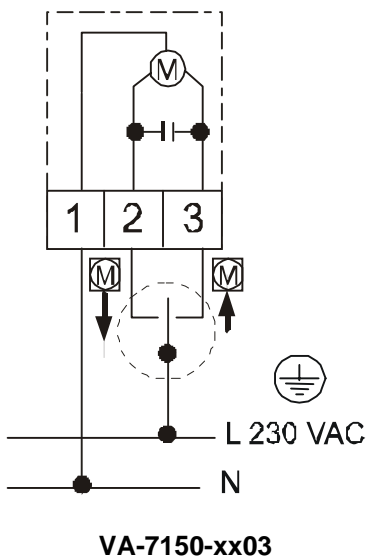

Adjustments for proportional models

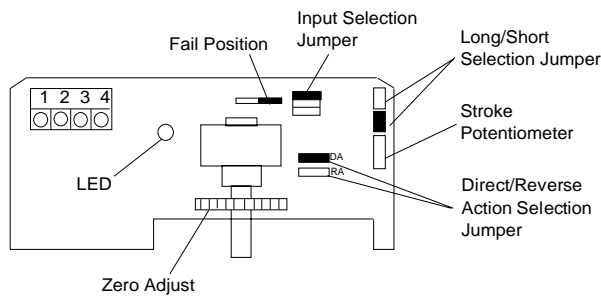

4. Set the signal fail position jumper to select default position fully retracted or fully extended. If the signal is lost at the actuator (open connection), the actuator will default to this pre-designated position.
5. Apply voltage specified by application requirements to drive the actuator stem to the fully retracted position using the following chart:

VA-7152 Components

The setting from the factory is: Direct acting mode, 1 to 9 ± 0.5 VDC for use with 0 to 10 VDC controller, 19 mm stroke and "signal fail" safe position jumper is set for fully retracted.

Application Values	Calibration Values
0-10	1-9
0-5	1-4
5-10	6-9

Note: Use of the calibration values will ensure proper shutoff throughout the life of the valve (compensates seat wear).

DA: fully retracted (minimum voltage)

RA: fully retracted (maximum voltage)

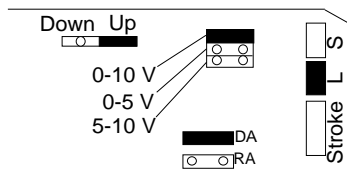

VA-7152 Calibration Values

Jumpers

Calibration

1. Set the input selection jumpers to match the desired operating range:
 - Top Jumper = 0 to 10 V
 - Center Jumper = 0 to 5 V
 - Bottom Jumper = 5 to 10 V
2. Set the short/long stroke selection jumper:
 - Short for 13 mm or less
 - Long for over 13 mm
3. Set the direct/reverse action jumper so that the valve stem travels in the desired direction (per changes in control signal):
 - Direct Action DA (Top jumper) = stem extends on signal increase
 - Reverse Action RA (Bottom jumper) = stem retracts on signal increase

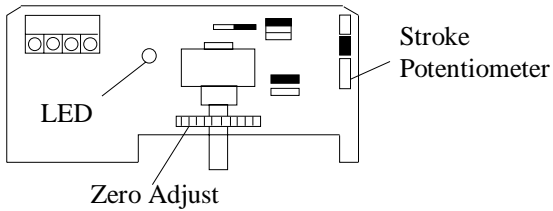

VA-7152 Adjustments

6. To ensure that the valve stem is in fully extended position, turn the zero-adjust knob anti-clockwise, until the valve stem reaches the end of stroke.
7. Slowly turn the zero-adjust knob clockwise and stop as soon as the LED flashes or extinguishes.

Note: The LED will illuminate while the actuator is in operation. The actuator circuit contains a time out feature. If calibration takes longer than 3 - 10 minutes, the LED extinguishes, indicating a false satisfied condition. If this occurs, turn off the power, wait several seconds, turn the power on, and then readjust the zero-adjust knob.

8. Apply the input voltage specified by application requirements to drive the valve stem to the fully retracted position per calibration value.
9. To ensure that the valve stem is in the fully retracted position, adjust the stroke potentiometer fully clockwise until the valve stem reaches the end of stroke.
10. Slowly turn stroke potentiometer anti-clockwise until LED extinguishes.
11. Adjust voltage to drive actuator to the fully retracted position. Verify zero adjustment.

12. Check for proper operation using the desired minimum and maximum operating voltages. Allow the actuator to operate through several complete cycles.

Note: The LED will remain illuminated for 3-10 minutes after the actuator has completed operation cycle.

13. Replace the cover and secure with the screw. The unit is ready for operation.

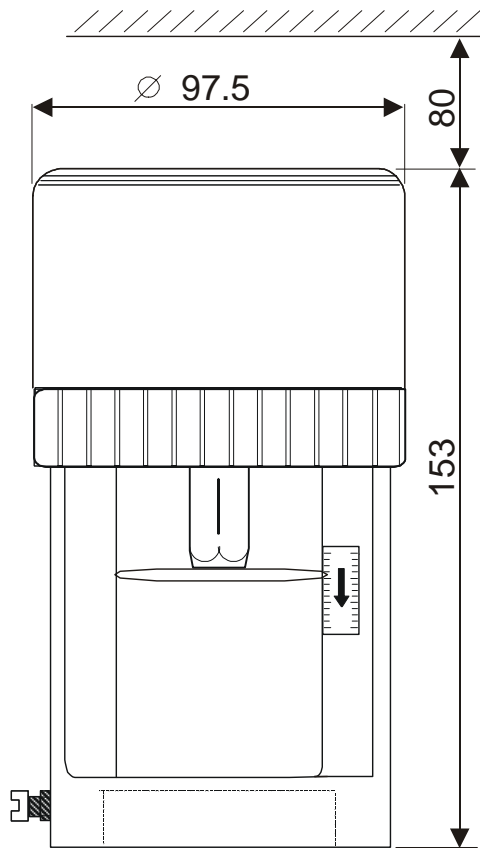
Dimensions (in mm)

VA-715x-100x

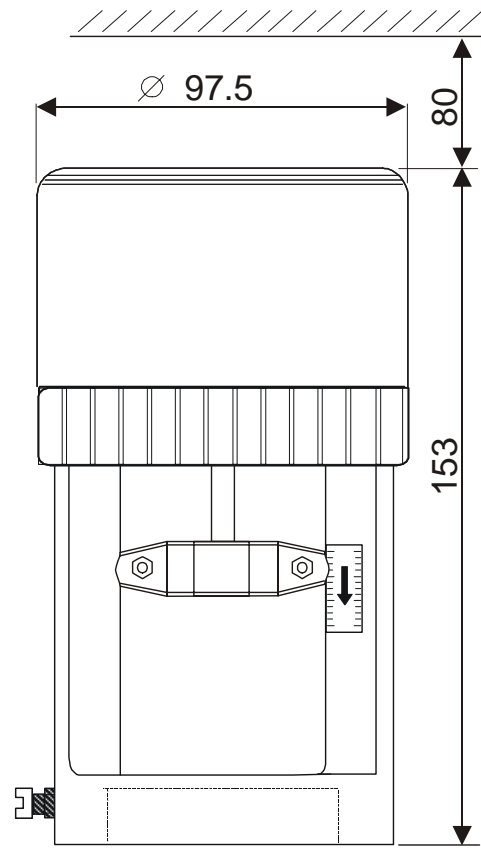

VA-715x-820x

Specifications

Models:	Floating		Proportional
Action / control:	Optional 0...10 VDC feedback Optional 2 k Ω feedback Optional 1 aux. switch		0...10 VDC
Type of motor:	Synchronous / reversible		
Supply voltage (50/60 Hz):	230 V \pm 15%	24 V \pm 15%	24 V \pm 15%
Motor ratings:	2.7 VA	2.7 VA	2.7 VA
Electronic positioner ratings:	-		2 VA 100 k Ω input impedance
Actuator force:	500 N \pm 20%		
Stroke:	20 mm maximum		
Nominal speed at 50 Hz (60 Hz):	10 (8.5) s/mm		
Enclosure protection:	IP 40 (IEC 60529)		
Materials:	Self extinguishing VO-UL 94 ABS + PC		
Enclosure:	Die cast aluminium		
Yoke:			
Ambient Operating condition:	-5 to +55 $^{\circ}$ C, non condensing		
Ambient Storage condition:	-20 to +65 $^{\circ}$ C, non condensing		
Electrical connections:	2.5 mm ²	2.5 mm ²	1.5 mm ²
Optional pcb:	-	1.5 mm ²	1.5 mm ²
Net weight:	0.8 kg		
CE Compliance:	European Directives: EMC (89 / 336 EEC) according to standard EN 50081-1 and EN 50082-1 LVD (73 / 23 EEC) according to standard EN 60335		

*The performance specifications are nominal and conform to acceptable industrial standards. For application at conditions beyond these specifications, consult the local Johnson Controls office.
Johnson Controls, Inc. are not liable for damages resulting from misapplication or misuse of its products.*

**JOHNSON
CONTROLS**

Johnson Controls International, Inc.

Headquarters:

European Customer Service Center:

European Factories:

Branch Offices

Milwaukee, Wisconsin, USA

Westendhof 3, D-45143 Essen, Germany

Essen (Germany), Leeuwarden (The Netherlands) and Lomagna (Italy)

Principal European Cities.

: Printed in Germany