



techsystem

automatyka klimatyzacja wentylacja

▸ zapoznaj się z naszą ofertą

VA-7310 Electric Valve Actuator

Introduction

The VA-7310 electric valve actuator is available with 3-point (floating), 3-point with feedback signal or proportional control.

These actuators are available with 100 N and 150 N nominal force. They can be used in combination with the: VB-5040-S, VB-5030, VB-7040 and VG7000 series valves, in accordance with the specified maximum close-off pressure ratings (see the pertinent valve bulletin).

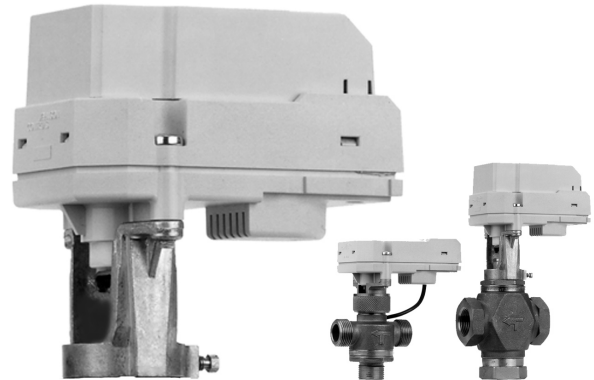

VA-7310 with VB-5040 (left) and VG-7000

Features and Benefits

- | | |
|----------------------------------------------------------------------------------------------------------------|--------------------------------------------------------------|
| <input type="checkbox"/> Only one Setscrew for in-situ installation | Easy installation, greater flexibility in actuator selection |
| <input type="checkbox"/> 3-point models with position switches, 0...10 V or 2 kΩ feedback are available | Flexibility in application |
| <input type="checkbox"/> Magnetic clutch and built-in electronic timer | Constant close-off force and long life design |
| <input type="checkbox"/> Manual override using standard 5-mm Allen key | Allows easy manual positioning |
| <input type="checkbox"/> Proportional 0...5, 0...10, or 5...10 V control selectable in-situ | Allows sequence control |

Ordering data

VA-7310-801

Valve Type	
0	VB-5030, VB-7040 and VG7000
8	VB-5040-S
Options	
Floating models	
0	None
1	0...10 V feedback *
3	2 kΩ feedback potentiometer *
4	Sequence limit switch *
5	Auxiliary Switch *
Proportional (0...10 V) models	
2	None

* on request

Ordering procedure

The actuator can be ordered as a separate unit or a factory fitted valve-actuator combination. Should the latter be requested, please just add “+M” to the end of the actuator ordering code.

For example:

Item 1 **VG7201AS** (valve body)
 Item 2 **VA-7312-8001** (actuator)

Alternatively, to order a factory fitted combination.

Item 1 **VG7201AS** (valve body)
 Item 2 **VA-7312-8001+M** (actuator)

Actuator-Valve combinations

The VA-7310 can be combined with the following valve ranges:

● VB-5040-S Series forged brass valves

- VB-5440-S 2-way Push Down To Open (PDTO)
- VB-5540-S 3-way mixing with built-in Normally Open bypass
- VB-5840-S 3-way mixing

● VB-5030 Series forged brass valves

- VB-5239-10 2-way Push Down To Close (PDTC)
- VB-5439-10 2-way Push Down To Open (PDTO)
- VB-5539-10 3-way mixing with built-in Normally Open bypass
- VB-5639-10 3-way mixing with built-in Normally Closed bypass
- VB-5839-10 3-way mixing

● VB-7040 Series bronze valves

- VB-7249-000 2-way Push Down To Close (PDTC)
- VB-7449-000 2-way Push Down To Open (PDTO)
- VB-7849-000 3-way mixing

● VG-7000 Series Bronze Valves / slotted stem

Only DN 15 and DN 20 valves with brass trim can be combined with the VA-7310.

- VG721S 2-way Push Down To Close (PDTC)
- VG741S 2-way Push Down To Open (PDTO)
- VG782S 3-way mixing

Operation

Floating models.

See also the pertinent valve product bulletin for valve operation.

Red cable energised:



Actuator stem extends.

White cable energised:



Actuator stem retracts.

Proportional models

Jumper function	Input control signal	Actuator Stem
Direct action	increases	extends
	decreases	retracts
Reverse action	increases	retracts
	decreases	extends

“Signal fail” position.

A signal failure on proportional models, will cause the actuator to automatically take the minimum.

Timer function

All models (Proportional and 3-point) are equipped with an internal electronic timer which prevents the motor from running in the same direction continuously for more than 2 minutes.

Mounting instructions

When mounting the actuator on a valve, please follow the instructions below:

- It is recommended that the valves be mounted upright in an easily accessible location. When mounted horizontally, the yoke should be fitted such that the stanchions are aligned vertically, one above the other.

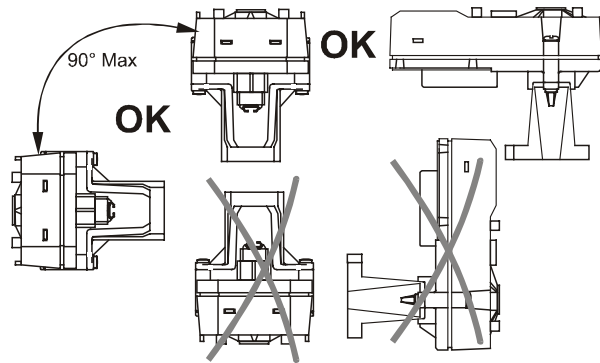

- The actuator must be protected against dripping water, which could enter the housing and damage the mechanism or motor.
- Do not cover with insulating material.
- Sufficient clearance must be allowed for actuator removal (refer to the dimension drawings).
- The valve must be installed so that the plug seats against the flow, as indicated by the arrows on the valve.

Wiring instructions

- All wiring must be in accordance with local regulations and national electrical codes and should be carried out by authorised personnel only.
- Make sure that the line power supply is in accordance with the power supply specified on the device.
- See also the instructions in paragraph "Application".

Note: The actuator stem must be completely retracted before installation is carried out.

WARNING

Shock Hazard

Disconnect the power supply before wiring connections are made to prevent personal injury.

Equipment Damage Hazard

Make and check all wiring connections before applying power to the system. Short circuited or improperly connected wires may result in permanent damage to the unit.

Wiring Diagrams:

Proportional model

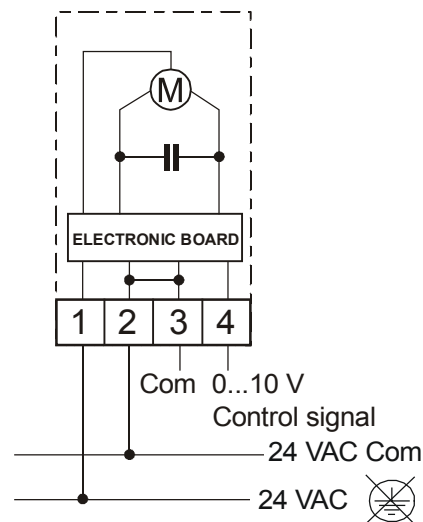

VA-7312

Floating models.

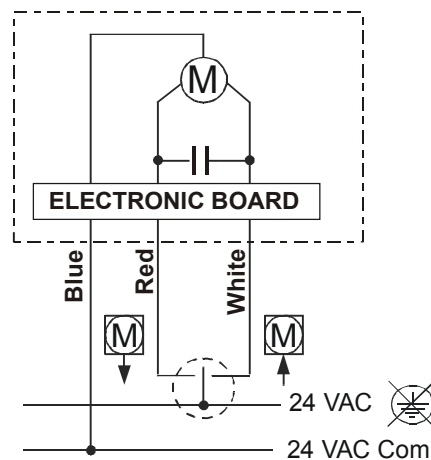

VA-7310

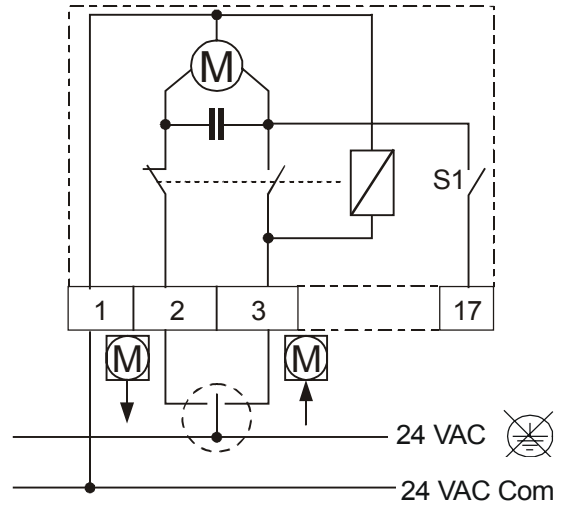
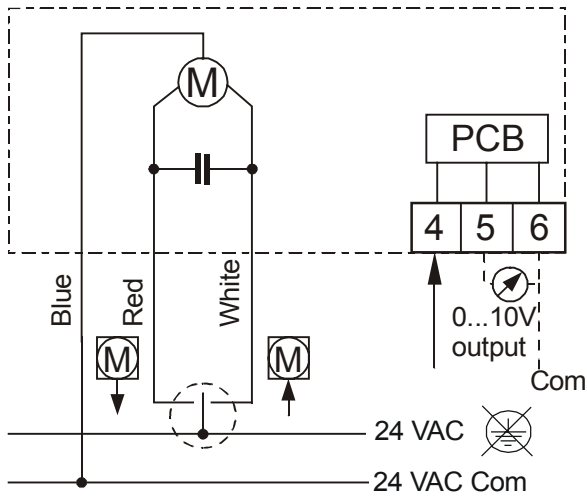

VA-7314

Actuator Stem	Feedback signal 5 (Jumper selection)	
	D.A.	R.A.
Extends	Increases	Decreases
Retracts	Decreases	Increases

VA-7311

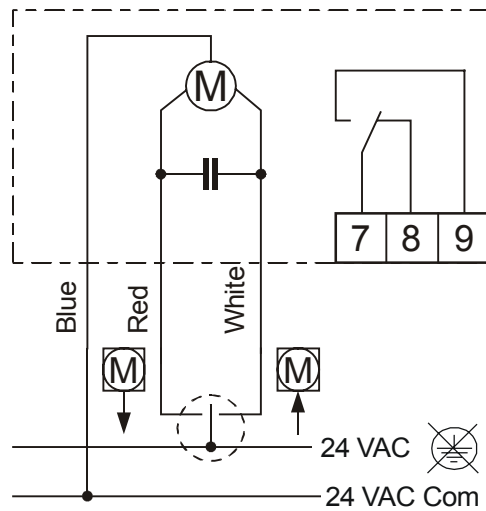

VA-7315

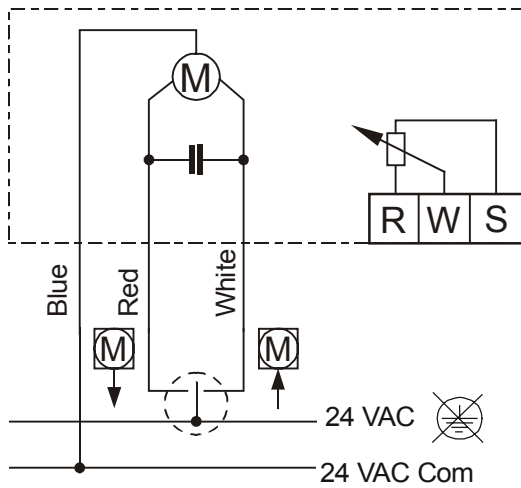

Actuator Stem	Feedback signal	
	R-W	R-S
Extends	Decreases	Increases
Retracts	Increases	Decreases

VA-7313

Adjustments

⚠ WARNING

Shock Hazard

Great care must be taken when the cover is removed (by authorised personnel only) for adjustment or inspection.

In all other cases when the cover is removed the power must be switched off.

Do not touch or attempt to connect or disconnect wires when the electrical power is on.

VA-7311 Jumper Settings

The feedback signal 0...10 V is proportional to the actuator stroke of 8 mm. Fine adjustment is carried out through 2 potentiometers and D.A. or R.A. which are selected by jumper:

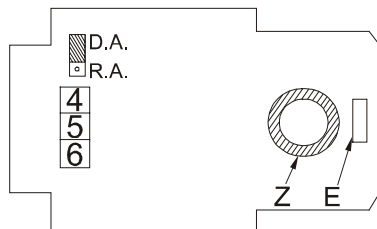

Z: Potentiometer for starting point fine adjustment.

E: Potentiometer for span fine adjustment.

Note: The feedback signal is factory set at 1...9 V, D.A.

VA-7312 Jumper Settings

The actuator stroke is proportional to the input control signal (0...5 V, 0...10 V or 5...10 V) and selectable in-situ through a jumper, with fine adjustment through a potentiometer. The action (D.A. or R.A.) is also selectable through jumper.

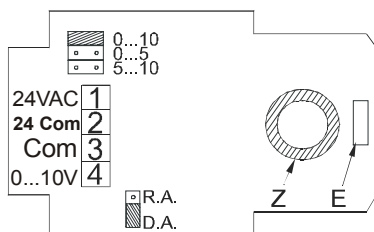

Z: Potentiometer for starting point fine adjustment.

E: Potentiometer for span fine adjustment.

Note: The control signal is factory set at 0...10V (1...9 V effective), D.A.

Applications

Sequential operation of proportional VA-7312

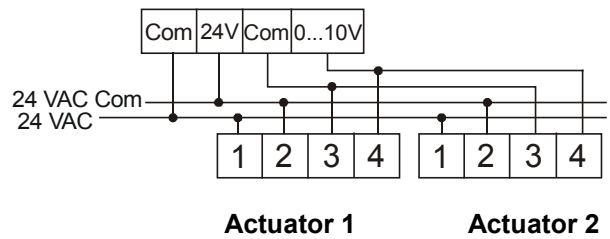

Example: 1 Heating- and 1 Cooling PDTC (NO) valve in sequential operation.

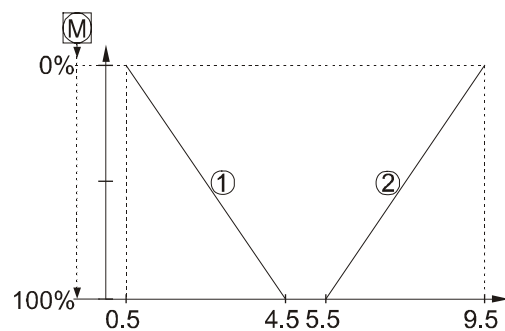

Adjustments	Jumper "DA-RA"	Jumper "Control signal"
Actuator 1	DA	0...5
Actuator 2	RA	5...10

Sequential operation of two floating actuators with a floating controller, type TC-8803:

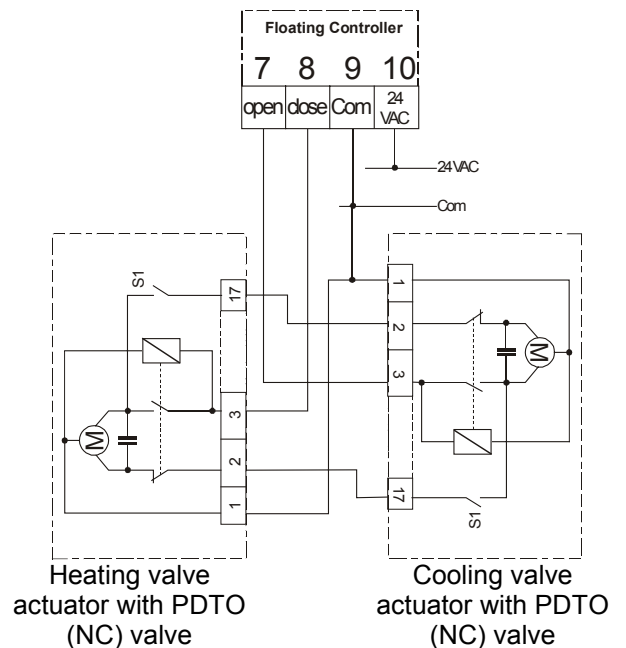

Dimensions (in mm)

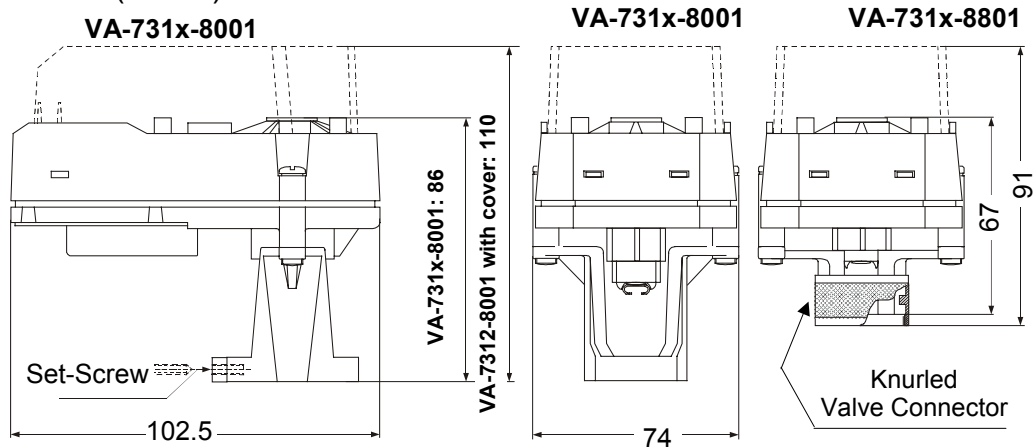

Specifications

Models:	VA-7310 / -7313 / -7314 / -7315	VA-7311	VA-7312
Type of motor:	Synchronous with magnetic clutch		
Control:	Floating		Proportional 0...10 V
Options:	VA-7313: 2 k Ω feedback pot. VA-7314: Sequence limit switch VA-7315: Auxiliary switch	0...10 VDC position feedback signal, max 1 k Ω	
Motor rating:	24 VAC \pm 15%, (2VA)		
Additional circuit board Power supply:		15 VDC \pm 10%, 5 mA	24 VAC \pm 10% 2 VA
Input Signal:			0...5, 0...10, 5...10 VDC, 100 k Ω input impedance
Limit of auxiliary switch:	SPDT 2 (1) A, 24 VAC		
Manual override:	Standard 5 mm Allen key (not supplied with delivery)		
Nominal force:	VA-731x-8001:	150 N \pm 20%	
	VA-731x-8801:	90 N \pm 15%	
Nominal stroke:	VA-731x-8001:	8 mm (max 10 mm)	
	VA-731x-8801:	3 mm	
Nominal running speed:	50 Hz:	7.5 s / mm	
	60 Hz:	6.3 s / mm	
Enclosure protection:	IP40 (EN 60529)		
Materials			
Gears:	Acetal resin		
Enclosure:	Thermoplastic PPO glass filled -UL 94 V0		
Yoke:	Aluminium		
Ambient operating condition:	-5 to +55 $^{\circ}$ C, 10...90% RH non condensing		
Ambient Storage condition:	-20 to +65 $^{\circ}$ C, 10...90% RH non condensing		
Net weight:	0.28 Kg		
CE Compliance:	EMC 89/336 EEC according to the standard EN 50081-1 EN 50082-1		

The performance specifications are nominal and conform to acceptable industry standards. For application at conditions beyond these specifications, consult the local Johnson Controls office.
Johnson Controls, Inc. shall not be liable for damages resulting from misapplication or misuse of its products.

Johnson Controls International, Inc.
Headquarters: Milwaukee, WI, USA
European Headquarters: Westendhof 8, 45143 Essen, Germany
European Factories: Lomagna (Italy), Leeuwarden (The Netherlands) and Essen (Germany)
Branch Offices: Principal European Cities.
This document is subject to change

Printed in Europe