



# techsystem

automatyka klimatyzacja wentylacja

▸ zapoznaj się z naszą ofertą

## VA-7700 Series Electric Valve Actuator

The VA-77xx Series synchronous motor driven actuator, for valves in heating, ventilation and air conditioning applications, is available for floating (3-point) control or proportional control with 0-10 V position feedback signal. It provides a stroke capability of 8 mm to a maximum 20 mm. This compact, non-spring return actuator has a 500 N nominal force and responds to a variety of input signals. The actuator can be combined with VG7000, VG9000 and VGS8... valves in accordance with the maximum close-off pressure ratings specified (see pertinent valve product bulletins). They can be ordered as a separate unit or as a factory fitted valve / actuator combination.



**VA-7700 with VGS800W1N**

### Features and Benefits

<input type="checkbox"/> <b>Self adjusting proportional actuators</b>	Easy, quick and precise commissioning servicing
<input type="checkbox"/> <b>Column of 5 Light Emitting Diodes</b>	Allows easy visualisation of actuator stroke position and of the actuator status
<input type="checkbox"/> <b>Optional models with mechanical manual override</b>	Allows manual positioning independent of the power supply
<input type="checkbox"/> <b>Manual contact micro switch on all models with manual override</b>	Signals actuator mode status (automatic or manual) to external supervisory system.
<input type="checkbox"/> <b>IP54 protection class</b>	Allows installation in a wide range of environments
<input type="checkbox"/> <b>Unique "C" shaped yoke design</b>	Allows lateral mounting of the actuator reducing the vertical space over the valve needed for installation.
<input type="checkbox"/> <b>Positioner with selectable starting point and span, direct and reverse action modes</b>	Enables sequence control
<input type="checkbox"/> <b>Magnetic clutch</b>	Provides constant output force for close-off of valves, and protects motor in stall conditions
<input type="checkbox"/> <b>"Control-Signal failure" stem to pre-determined position</b>	Actuator pre-set position after a control signal failure (extended/retracted), is selectable in-situ

## Ordering data

### For VG7000 and VG9000 Series Valves:

Device code	Power supply	Manual override
<b>Floating models (3-point)</b>		
<b>VA-7700-1001</b>	24 VAC	None
<b>VA-7700-1003</b>	230 VAC	None
<b>VA-7740-1001</b>	24 VAC	Mechanical
<b>VA-7740-1003</b>	230 VAC	Mechanical
<b>Proportional models (0...10 VDC / 0 (4)...20mA)</b>		
<b>VA-7706-1001</b>	24 VAC	Electrical
<b>VA-7746-1001</b>	24 VAC	Electrical and Mechanical

These actuators can be combined with the following valve ranges:

- **VG7000 Series Threaded Valves**

Female and male threaded valves

**VG7** □□□□ T all body types DN 15...50

### For VGS8... Series Valves:

Device code	Power supply	Manual override
<b>Floating models (3-point)</b>		
<b>VA-7700-8201</b>	24 VAC	None
<b>VA-7700-8203</b>	230 VAC	None
<b>VA-7740-8201</b>	24 VAC	Mechanical
<b>VA-7740-8203</b>	230 VAC	Mechanical
<b>Proportional models (0...10 VDC / 0 (4)...20mA)</b>		
<b>VA-7706-8201</b>	24 VAC	Electrical
<b>VA-7746-8201</b>	24 VAC	Electrical and Mechanical

These actuators can be combined with the following valve ranges:

- **VGS8... Series Male Threaded Valves**

Male threaded valves

**VGS8** □□ W1N 3-way DN 15... 40  
2-Way DN 15... 50

- **VG9000 Series Flanged Valves**

Flanged valves

**VG9** □□□□ S1 □□ all body types DN 15...50

## Ordering procedure

The actuator can be ordered as a separate unit or a factory fitted valve-actuator combination. Should the latter be requested, please just add “+M” to the end of the actuator ordering code.

### For example:

Item 1 **VG7203NT** (valve body)

Item 2 **VA-7746-1001** (actuator)

Alternatively, to order a factory fitted combination.

Item 1 **VG7203NT** (valve body)

Item 2 **VA-7746-1001+M** (actuator)

## Operation

### Floating models

Connections	Actuator Stem
1-2	Extends
1-3	Retracts

### Proportional models

#### (0...10 VDC or 0(4)...20 mA)

The VA-77x6 provides a proportional stroke corresponding to the control signal.

Following control signals are defined as standard:

- 0...10 VDC
- 0...5 VDC
- 5...10 VDC
- 0...20 mA
- 4...20 mA

Action (DIP switch set)	Input control signal	Actuator Stem	position at control-signal failure *
Direct (DA)	Increases	Extends	Selectable*
	Decreases	Retracts	Selectable*
Reverse (RA)	Increases	Retracts	Selectable*
	Decreases	Extends	Selectable*

\* "Signal failure" position pre-set does not operate when 0...20 mA control is selected.

The action mode, **DA** (direct acting) and **RA** (reverse acting) is set through the .DIP switches (see paragraph "**DIP switch settings**").

The actuator control signal has a buffer zone, at each end of the span, of 0.3 V or 0.3 mA. This ensures definite valve close-off.

### Control signal failure pre-set position

(not functional with 0...20 mA control selected)

A control-signal failure on proportional models will cause the actuator to automatically move the stem to a (via DIP-switches) pre-selected position (100% extended or 100% retracted).

### Auto Calibration procedure with standard input signal ranges.

The standard control signals are selected by setting DIP switches 3 and 4 switch (see paragraph "**DIP switch settings**").

It is recommended to set the actuator to the desired control signal and action before fitting to the valve (see paragraph "**DIP switch settings**").

Power must be connected before the auto-calibration cycle can be started.

**Procedure:** Actuator is mounted on valve.

- Verify that with the stem fully retracted, there is a minimum distance of 1 mm between the top of the actuator stem nut and the stem guide bush in the actuator motor housing base plate. If necessary correct the distance by adjusting the actuator / valve stem connection.
- To start the auto calibration cycle, push both calibration buttons for at least 5 seconds. The actuator will make a full cycle to detect the stem extended and retracted limits.

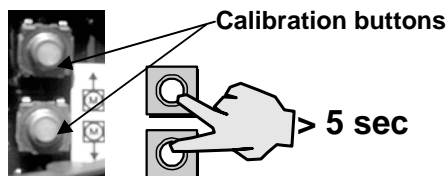

During auto-calibration cycle all five status indication LED flash simultaneously.

- When the auto calibration cycle is completed the LED stop flashing, the actuator stem moves to the position that corresponds to the control signal and the five LED indicate the stem position.
- When the control signal changes the actuator stem moves to the new position this is indicated by one flashing LED. The LED stops flashing when the position corresponding to the control signal has been reached.

**Note:** When ever the actuator is newly placed on a valve, auto – calibration must be carried out.

### Auto-calibration procedure for freely defined control signal ranges

Non standard control signals for example 2...8 VDC are applied by setting the DIP switches 3 and 4 (see paragraph "DIP switch settings").

It is recommended to set the actuator to the desired control-signal type and action before fitting to valve (see paragraph "DIP switch settings"). Power must be connected before the auto-calibration cycle can be started. It is recommended that the signal span is always set superior or equal to 3V or 6 mA in order to keep acceptable proportional characteristics.

**Procedure:** (Actuator is mounted on valve)

- Verify that with the stem fully retracted, there is a minimum distance of 1 mm between the top of the actuator stem nut and the stem guide bush in the actuator motor housing base plate. If necessary correct the distance by adjusting the actuator / valve stem connection.
- The auto calibration cycle is started by pushing both calibration buttons, on the pcb, simultaneously for at least 5 seconds. The actuator will then make a full cycle to detect the stem extended and retracted limits.

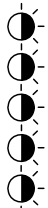
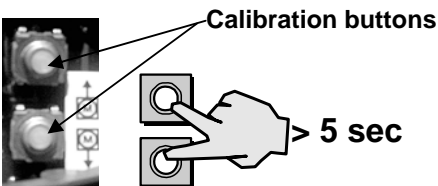

During auto-calibration cycle all five status indication LED flash simultaneously.

- Apply one of the control signal values **and confirm by pressing one of the two calibration buttons for 2 seconds (the 5 LED will illuminate for 5 sec to confirm the setting)**. Now apply the second control signal value and again **confirm by pressing one of the two calibration buttons for 2 seconds (the 5 LED will illuminate for 5 sec to confirm the setting)**.
- Both the minimum and the maximum control signal values are stored in the memory of the actuator.
- When the auto calibration cycle is completed the LED stop flashing, the actuator stem moves to the position that corresponds to the control signal and the five LED indicate the stem position.
- When the control signal changes the actuator stem moves to the new position this is indicated by one flashing LED. The LED stops flashing when the position corresponding to the control signal has been reached.

### Position feedback

The position feedback signal is for monitoring the actuator stroke position. It feeds information internally to the positioner and a 0-10 VDC signal can supply an external supervisory system.

### Electrical manual override

To select electrical manual override DIP switch 7 must be switched to "on" (right hand position; see paragraph "DIP switch settings"). The actuator stem can now be driven via the calibration buttons. The upper button retracts the stem and the lower button extends the stem. The stem remains in the position at which the button is released. Switch DIP switch 7 to "off" to return to automatic drive. The five LED indicate the stem position.

### Mechanical manual override

To select manual override turn the override knob from "AUT" to "MAN", the hand wheel is then engaged and power disconnected internally. Turning the hand wheel clockwise extends the stem and anti-clockwise retracts the stem. Turning the override knob to AUT disengages the hand wheel and reconnects the power.

- **The auxiliary switches (terminals 10, 11, and 12) can be used to indicate manual override or automatic mode.**

## DIP switches settings (Proportional models only)

The DIP switches are accessed by removing the transparent cover.

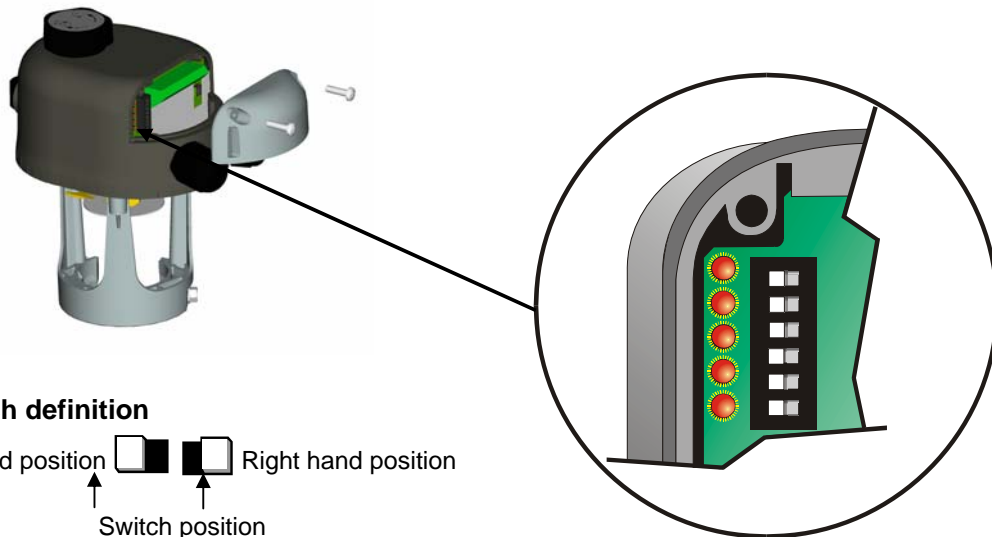

### DIP switch definition

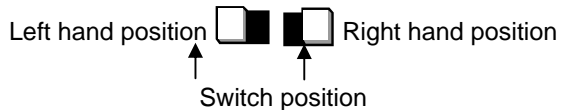

<b>1, 2: Control signal type</b>	1 <input type="checkbox"/> VDC	1 <input type="checkbox"/> mA
	2 <input type="checkbox"/> VDC	2 <input type="checkbox"/> mA
<b>3, 4, 5: Control signal ranges</b>	3 <input type="checkbox"/> 0..10 VDC	---
	4 <input type="checkbox"/> 0..10 VDC	
	3 <input type="checkbox"/> 0.5 VDC	---
	4 <input type="checkbox"/> 0.5 VDC	
	3 <input type="checkbox"/> 5..10 VDC	---
	4 <input type="checkbox"/> 5..10 VDC	
3 <input type="checkbox"/> Free Range	4 <input type="checkbox"/> Free Range	5 <input type="checkbox"/> 0..20 mA
	---	5 <input type="checkbox"/> 4..20 mA
<b>6: Action</b>	6 <input type="checkbox"/> DA	6 <input type="checkbox"/> RA
<b>7: Electrical Manual override</b>	7 <input type="checkbox"/> OFF	7 <input type="checkbox"/> ON
<b>8: Control-signal failure position pre-set*</b>	8 <input type="checkbox"/> Up	8 <input type="checkbox"/> Down

**Default setting from factory:** All switches in left hand position.

- 1. } Voltage control
- 2. }
- 3. } 0...10 VDC
- 4. }
- 5. ----
- 6. **Direct Acting mode**
- 7. Electrical manual override "off"
- 8. "Signal failure position" pre-set = "Up"

\* Does not operate with mA control.

### Standard operating mode

The LED display indicates the actuator stem position. The LED stops flashing when the position corresponding to the control signal has been reached.

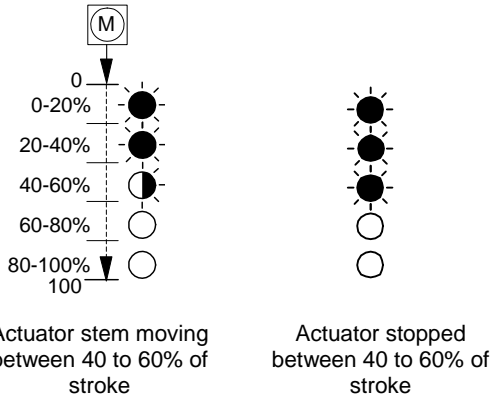

### Actuator status indication (Proportional models only)

The actuator microprocessor carries out a failure diagnosis when a failure has been detected. The actuator status is indicated by the LED display

#### LED definition

	LED permanently ON
	LED flashing
	LED permanently OFF

When the micro processor detects that the stem has come to an unexpected stop it initiates a retry cycle, this is repeated three times and if unsuccessful the actuator status is switched to **fault mode** and the LED indicate a general alarm code. If the problem is cleared however, the actuator continues normal function

### Fault mode

If the actuator enters fault mode, the LED will flash as shown. The indication is general and is displayed when:

- Stem comes to unexpected stop; retry cycle fails to clear problem.
- Freely defined control-signal settings are incomplete or not stored.
- Invalid E<sup>2</sup>PROM parameters

#### Specific fault indication

To indicate the specific fault press one of the calibration buttons for **2 seconds**. A fault diagnosis is displayed:

Specific alarm codes displayed by LED			
A	B	C	D
<b>Diagnosis</b>			
<b>A</b>	Calibration interrupted before completion or values missing		
<b>B</b>	Invalid E <sup>2</sup> PROM parameters		
<b>C</b>	Actuator stalled due to valve blockage		
<b>D</b>	Default E <sup>2</sup> PROM parameters defective		

When the problem has been solved, pressing **one of the calibration buttons** for at least 5 seconds will cause the actuator to leave the fault mode and the LED will show present actuator status. Standard operating mode.

## Applications: Parallel and sequential operation

### Actuators without built-in positioner for controllers with PAT (Positioning Adjusting Time) output in parallel operation

Although synchronous motors have the same running speed (rate of travel), deviation in travel between motors can accumulate during starts and stops because of varying loads. This deviation depends on the number of on/off cycles. By periodical switching of the actuators to end of travel, actuators running in parallel can be reasonably synchronous.

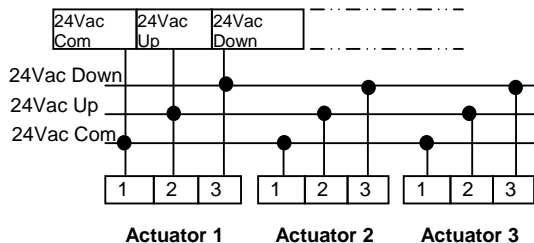

The number of actuators that can be linked to a single controller depends on the controller's active power in relation to the actuators power consumption.

### Actuators with built-in positioner for controllers with 0...10V output in parallel operation

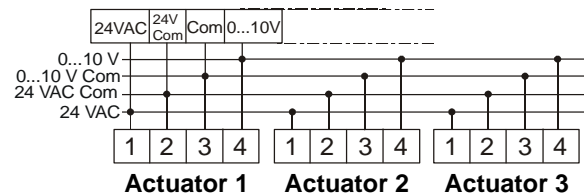

The controller 0...10 V output can operate several actuators with built-in electronic positioner. The number of actuators that can be linked to a single controller depends on the controller's active power in relation to the actuators power consumption. Each positioner has its own adjustment for starting point between 0...10 V. Each actuator can have a different input (for instance 0...5 VDC / 5...10 VDC) Each positioner can be switched for direct or reverse action.

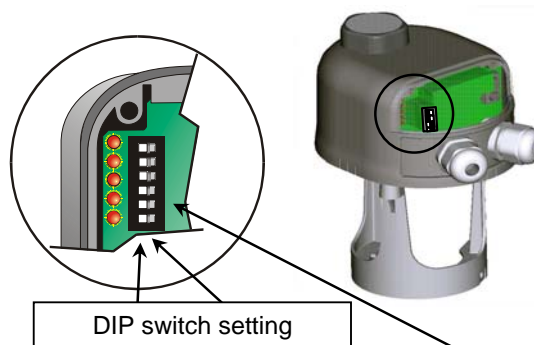

	Starting Point	End Point (Starting Point + Span)	Positioner Action	
Y1	0.3 V	9.7 V	DA	Factory Setting
Y2	5.3 V	9.7 V	RA	
Y3	6.0 V	8.0 V	DA	

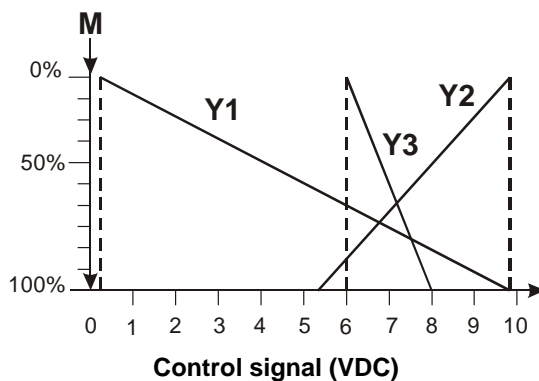

## Mounting instructions

When mounting the actuator on a valve, please follow the instructions below:

- It is recommended that the valves be mounted upright or at angles not greater than 90° in an easily accessible location.

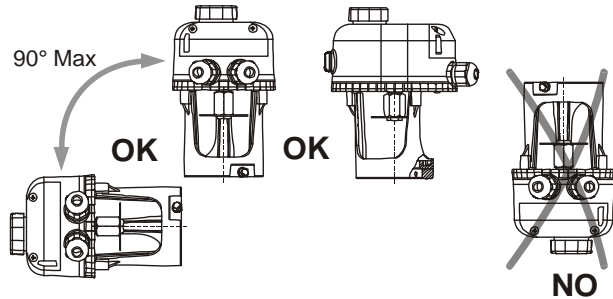

- The actuator must be protected against dripping water, which could enter the housing and damage the mechanism or motor.
- Do not cover with insulating material.
- Sufficient clearance must be allowed for actuator removal (refer to the dimension drawings).
- The valve must be installed so that the plug seats against the flow, as indicated by the arrows on the valve.



### CAUTION

- These actuators are intended to control equipment under normal operating conditions. Where failure or malfunction of the actuator could lead to an abnormal operating condition that could cause personal injury or damage to the equipment or other property, other devices (limit or safety controls) or systems (alarm or supervisory systems) intended to warn of or protect against failure or malfunction of the actuator must be incorporated into and maintained as part of the control system.

## Wiring instructions

- All wiring must be in accordance with local regulations and national electrical codes and should be carried out by authorised personnel only.
- Make sure that the line power supply is in accordance with the power supply specified on the device.
- See also the instructions in paragraph "Application".



### WARNING

#### Shock Hazard

- Disconnect the power supply before wiring connections are made to prevent personal injury.

#### Equipment Damage Hazard

- Make and check all wiring connections before applying power to the system. Short circuited or improperly connected wires may result in permanent damage to the unit.

## Wiring Diagrams

(Models with mechanical manual override)

### CAUTION

#### Equipment Damage Hazard

- On 24 V models with manual override, it is not permitted to connect voltages greater than 24 V to terminals 10, 11, and 12

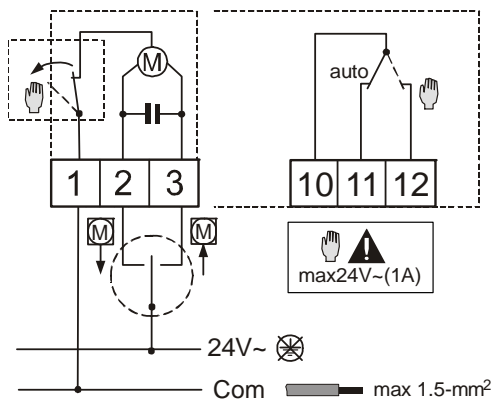

**VA-7740-xx01**  
Floating models, 24 VAC supply

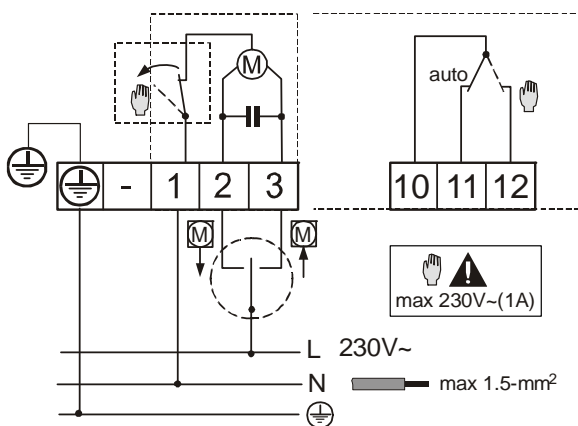

**VA-7740-xx03**  
Floating models, 230 VAC supply

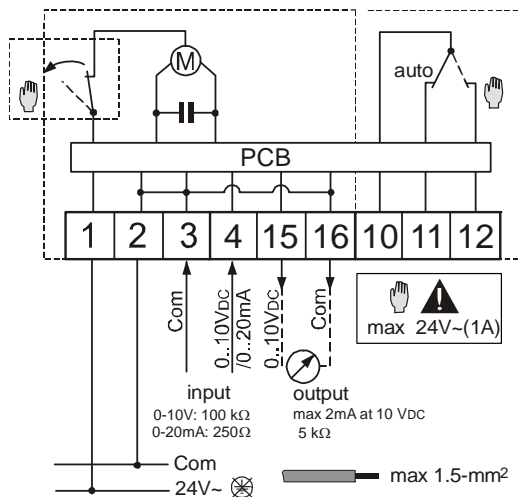

**VA-7746-xx01**  
Proportional models, 24 VAC supply

## Wiring Diagrams

(Models without mechanical manual override)

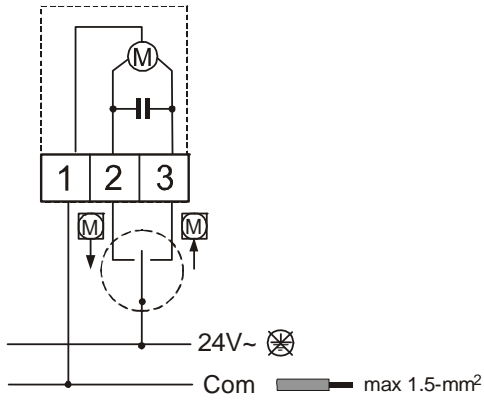

**VA-7700-xx01**  
Floating models, 24 VAC supply

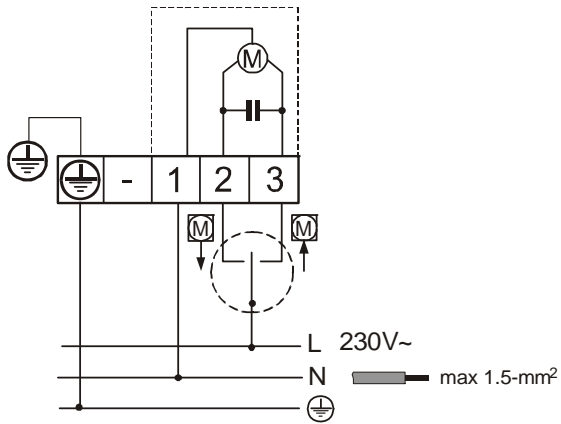

**VA-7700-xx03**  
Floating models, 230 VAC supply

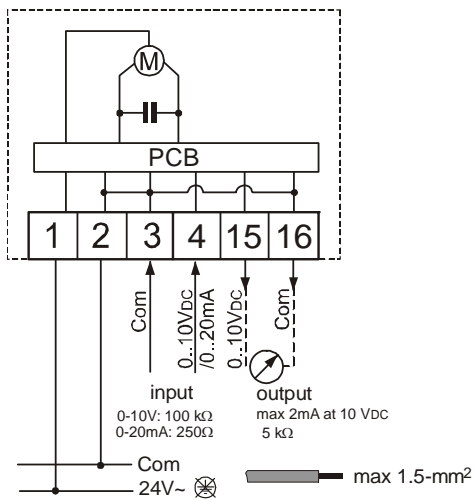

**VA-7706-xx01**  
Proportional models, 24 VAC supply

**Dimensions (in mm)**

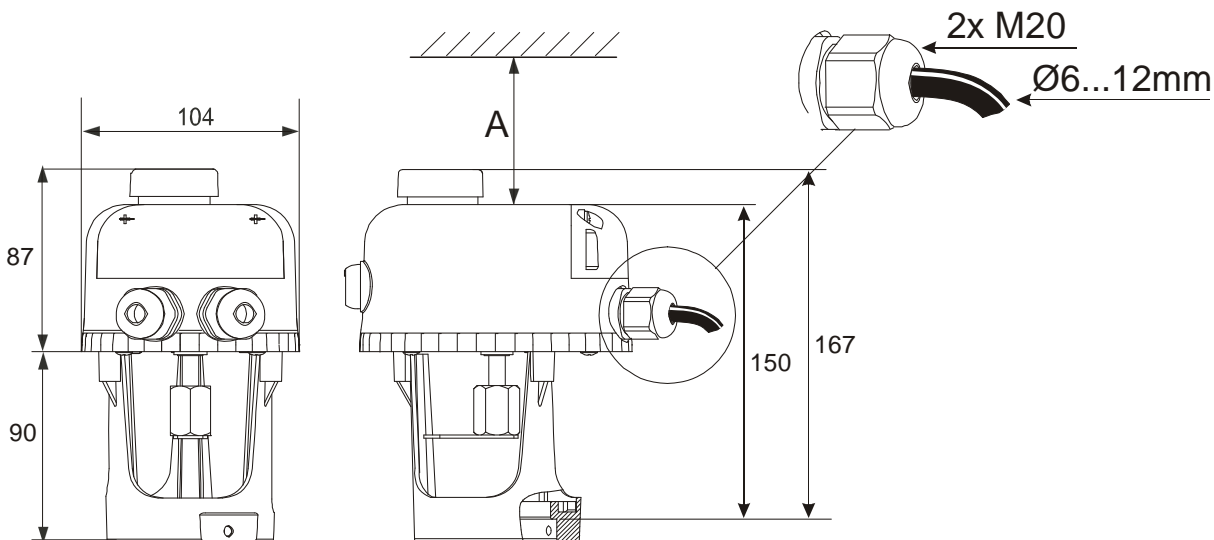

**VA-77xx-10xx**

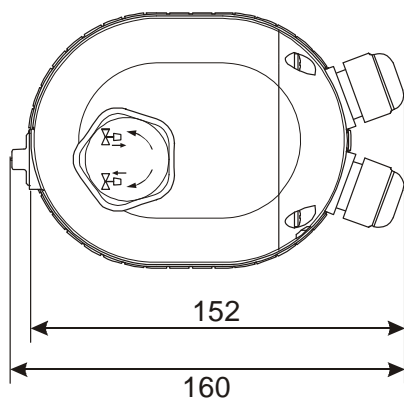

A	25 mm	VA-770x actuators without manual override
A	80 mm	VA-774x actuators with manual override

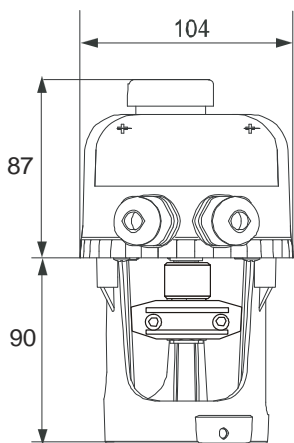

**VA-77xx-82xx**

## Technical Specifications

Product		VA-7700		
Models		Floating		Proportional
Supply voltage	230 V ± 15 % 50/60 Hz	24 V ± 15% 50/60 Hz		24 V ± 15% 50/60 Hz
Control signal	Positioner Adjustment Time (PAT)			0...10 VDC or 0(4)...20 mA
Feedback signal	0...10 VDC			
Mechanical Manual override				Electrical
VA-770x	None			
VA-774x	Mechanical			Electrical + Mechanical
Type of motor	Synchronous / reversible			
Max. Power Consumption				
active	3.5 W	2.6 W		3.2 W
apparent	3.9 VA	2.6 VA		4.7 W
Electronic positioner Input impedance	-			100 kΩ min. (0...10 VDC) 250 Ω (0(4)...20 mA)
Resolution	0.5 % (up to 200 steps on 20 mm stroke)			
Feedback ratings	max 2mA at 0..10 VDC, 5 kΩ			
Manual contact micro-switch max. load	2A Resistive 1A Inductive, 24 VAC (24 V switch) 2A Resistive 1A Inductive, 230 VAC only for VA-7740-1003			
Force	500 N ± 20%			
Stroke	20-mm maximum			
Nominal full stroke time	mm	50 Hz	60 Hz	
	8	84 s	70 s	
	13	137 s	114 s	
	19	200 s	167 s	
Enclosure protection	IP54 (IEC 60529)			
Materials	<b>Cover:</b> Self extinguishing ABS + polycarbonate PC <b>Wiring Cover:</b> Polycarbonate <b>Hand wheel:</b> Polyamide PA66 <b>Yoke:</b> Die cast aluminium <b>Plates:</b> Zinc plated steel <b>Gears:</b> Acetylic resin			
Ambient Operating Condition	-5 to +55, °C, 10...90% RH non condensing			
Ambient Storage Condition	-20 to +65 °C, 10...90% RH non condensing			
Wiring	2.5 mm <sup>2</sup> terminal block			
Wiring entrance	(2) M20x1.5 cable conduit adapters – for separated power/accessories wiring access (cables from Ø6-mm to Ø12-mm)			
Net weight	0.8 kg			
Life time	tested for 250,000 full cycles			
CE Compliance	89/336 EEC directive: EN 50081-1, EN 50082-1 73/23 EEC directive: EN 60730			

The performance specifications are nominal and conform to acceptable industry standards. For application at conditions beyond these specifications, consult the local Johnson Controls office. Johnson Controls, Inc. shall not be liable for damages resulting from misapplication or misuse of its products.



Johnson Controls International, Inc.  
 Headquarters: Milwaukee, Wisconsin, USA  
 Branch Offices: Principal Cities World-wide