



techsystem

automatyka klimatyzacja wentylacja

▸ zapoznaj się z naszą ofertą

VA-747x Electronic Terminal Unit Valve Actuator

Product Bulletin

PB_VA-747x
Issue Date 03 2008

The VA-747x Series provides incremental or proportional control in HVAC applications. The compact design of this actuator makes it suitable for installation in confined spaces, such as fan coil applications.

The VA-747x Series actuator is designed for field mounting onto VG6000 and V5000 Terminal Unit Valves (see *pertinent bulletin*).



VA-747x series actuator

Table 1: Features and Benefits

Features	Benefits
Compact design	Allows installation in confined spaces (fan coils, etc.).
Auto-commissioning	Simplifies installation because models require no adjustments in the field.
Motor Time-out feature	Extends actuator life by reducing drive time and therefore motor wear.
Can be mounted on site	Simplifies installation; allows application flexibility.
Periodic full cycle (anti-sticking) option	Keeps plug and seat clear of impurities.
LED operating status display	Reduces the commissioning time and displays operating status.

Ordering Codes

Codes	Control Type	Supply voltage	Configuration Options
VA-7470-1001	Floating	24 VAC \pm 15%	---
VA-7472-1001	Proportional		---
VA-7472-9001			<ul style="list-style-type: none">• Selectable input signals for range splitting (0 to 10, 0 to 5, 5 to 10 VDC).• Direct or Reverse Action• Selectable Anti-sticking cycle

All actuators fitted with 1.5 m cable.

Models with other cable lengths are available on request.

Actuator combinations



The VA-747x series electronic valve actuators are designed to be used with VG6000 valve series.

Please refer to the "VG6000 Series Forged Brass Valves" and "V5000 Terminal Unit Valves Series" Product Bulletin for complete ordering informations.

Operation

Floating model (VA-7470-1001)

Please refer to the "VG6000 Series Forged Brass Valves" and "V5000 Terminal Unit Valve Series" Product Bulletin for valve operation.

Red cable energised		Actuator stem extends
White cable energised		Actuator stem retracts

When the signal is applied to the blue and red wires, the actuator stem extends. When the signal is removed the actuator remains in position.

If the signal remains applied to the red or to the white wire, the actuator will time out and shut off the motor after approximately 80 seconds.

When the signal is applied to the blue and white wires, the actuator stem retracts. When the signal is removed the actuator remains in position.

If the signal remains applied to the blue or to the white wire, the actuator will time out and shut off the motor after approximately 80 seconds.

End of stroke Confirmation: When the signal is applied continuously in the same direction, the actuator turns on every 2 hours and drives in the signal direction for approximately 80 seconds to confirm the end of stroke position.

Proportional models (VA-7472-1001 and VA-7472-9001)

Please refer to the "VG6000 Series Forged Brass Valves" and "V5000 Terminal Unit Valve Series" Product Bulletin for valve operation.

VA-7452-1001 has fixed settings

(see curve ①)

VA-7452-9001 configurable:

Action: When the signal increases in Direct Action (DA) configuration or decreases in Reverse Action (RA) configuration, the actuator motor drives the gear assembly, pushing down on the valve return spring. When the signal decreases in DA configuration or increases in RA configuration, the actuator retracts and allows the valve return spring to move the valve stem in the direction of its normal position or up.

Jumper 5 "Direct Action"

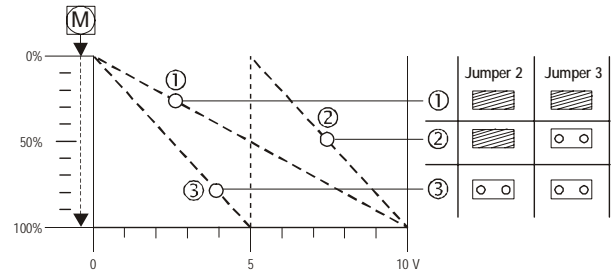

Jumper 5 "Reverse Action"

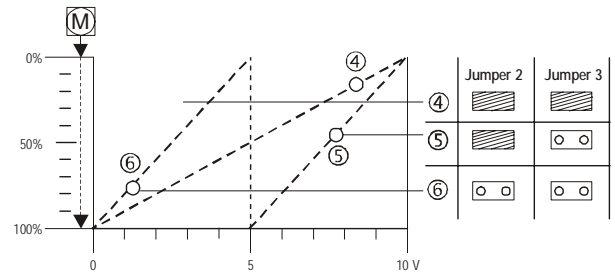





End of stroke confirmation: When the input signal is at 0 or 100% continuously, the actuator turns on every 2 hours and drives in the signal direction for approximately 80 seconds to confirm the end-of-stroke position.

Self-Calibration cycle: when the power is applied, the actuator self-calibrates to the full stroke end position by performing a complete cycle. The actuator drives in the stem down direction for approximately 80 seconds, then drives to the input signal command position.

Anti-Sticking Cycle (VA-7472-9001): When the anti-sticking cycle is enabled (ON), the actuator performs one complete cycle every 24 hours to clear possible accumulation of impurities from the valve plug and seat. The anti-sticking feature is selectable through jumper 1.

Operating status indication

ON		Power supply present, motor not running. <ul style="list-style-type: none"> Floating actuators: time out Proportional actuators: actuator is in control
Single Blinking		Motor is running
Double Blinking		Actuator performs an end-of-stroke confirmation cycle or an anti-sticking cycle
OFF		Power supply is not present

Mounting instructions

When mounting the actuator on a VG6000 and V5000 valve, please follow the instructions below:

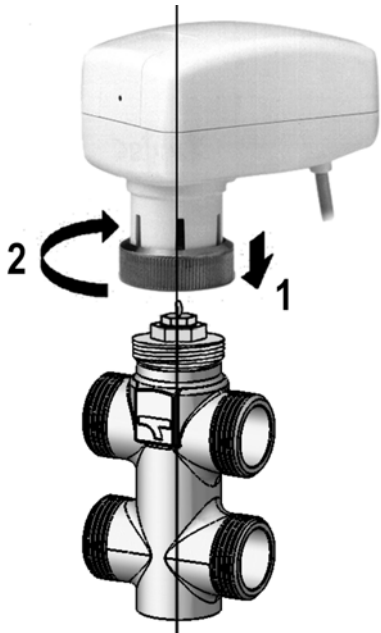

- Never use the actuator as a mounting lever.
- Mounting position:

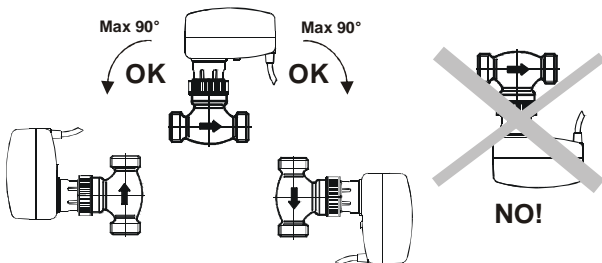

Wiring instructions

WARNING

When servicing make sure that:



- The electric supply to the actuator is switched off to avoid possible damage to the equipment, personal injury or shock.
- You do not touch or attempt to connect or disconnect wires when electric power is on.

When wiring the actuator, please follow the instructions below:

- Before mounting, wiring or adjusting the actuator, make sure that the power supply has been disconnected to avoid possible harm to material or person.
- Make sure that the line power supply is in accordance with the power supply specified on the actuator.

All wiring should conform to local codes and must be carried out by authorised personnel only.

Wiring Diagrams

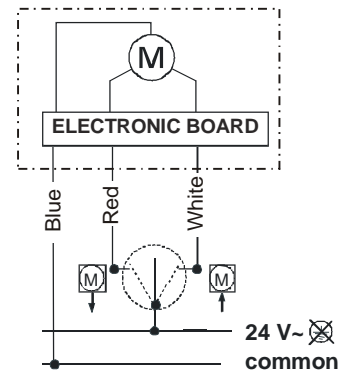

VA-7470-1001 Floating Model

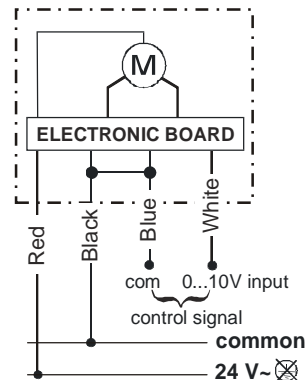

VA-7472-1001 and VA-7472-9001
Proportional Models

Adjustments (jumper settings) of proportional models

VA-7472-9001 is configurable. This is how the jumpers are positioned on the board: 6



Jumper in place:

Jumper removed:

Function	Jumper No.	VA-7472-9001 (adjustable)	
		Factory setting	Alternative setting
Anti-sticking	1	enabled	disabled
Input control signal	2	0...10 V	5...10 V 0...5 V
	3		5...10 V 0...5 V
No Function	4	No function	---
Action	5	Direct (DA)	Reverse (RA)
No Function	6	No function	---

Dimensions in mm

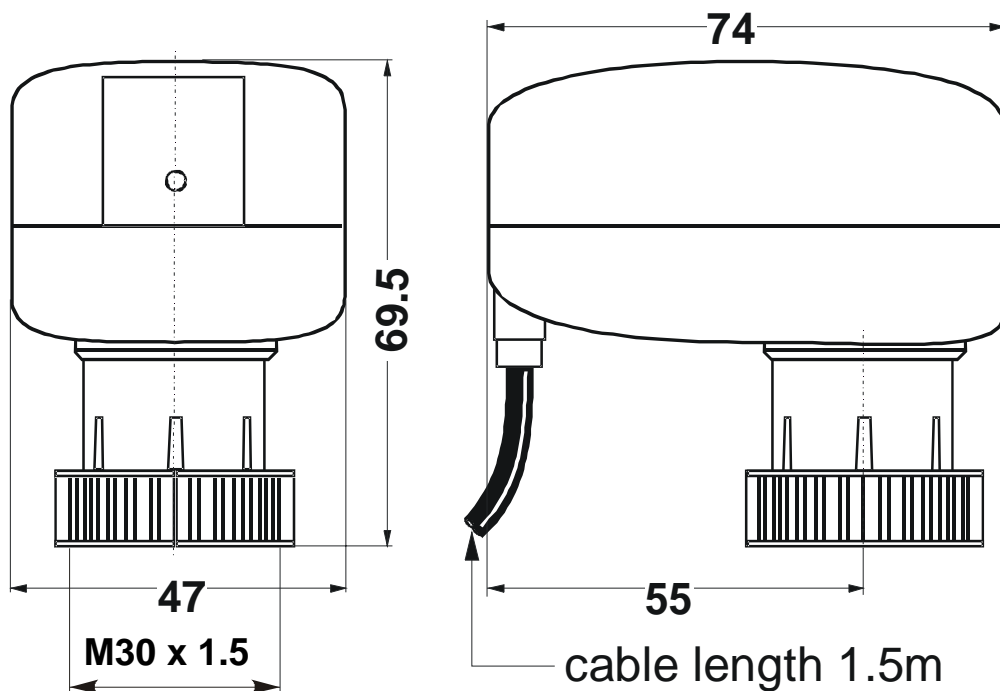

Technical Specifications

Models	VA-7470-1001	VA-7472-1001: Fixed settings (not configurable) VA-7472-9001: Configurable
Action/Control	Floating or PAT	Proportional (0...10 V, 0...5 V or 5...10 V)
Supply voltage (50/60 Hz)	24 VAC ±15%	
Input impedance	---	80 kΩ
Power consumption	Apparent: 2.7 VA at max. power supply Active: 2 W	
Nominal force	120 N +30% / -20%	
Maximum stroke	5 mm	
Running Time	15 s/mm	
Protection	IP40 (EN 60529)	
Material	Housing / Yoke: PA66 - Glass + Mineral filled (30% total) Kelon A FR CETG/300-V0 Fitting: Brass CuZn40Pb2	
Fitting thread	M30 x 1.5	
Housing colour	RAL7035	
Ambient Operating Condition	0°C to 50°C, non condensing	
Ambient Storage Condition	-20°C to 65°C, non condensing	
Max. fluid temperature	95°C	
Electrical connections	1.5 m flexible cable, Ø 4.5 mm	
Operating status indication	LED	
Audible Noise Rating	<30 dB(A)	
Shipping Weight	0.15 Kg	
CE Compliance	Directive 89/336 EEC: EN 61000-6-1; EN 61000-6-3	

The performance specifications are nominal and conform to acceptable industry standards. For application at conditions beyond these specifications, consult the local Johnson Controls office. Johnson Controls, Inc. shall not be liable for damages resulting from misapplication or misuse of its products.

Johnson Controls International, Inc.

Headquarters: Milwaukee, Wisconsin, USA

Branch Offices: Principal Cities World-wide

