



techsystem

automatyka klimatyzacja wentylacja

▸ zapoznaj się z naszą ofertą

Proportional Actuators AC 230 V
2.26 N

Application

The **JOHNSON CONTROLS STANDARD** electric damper actuator series is designed to operate air dampers in ventilation and air conditioning systems.

The compact design and universal adapter fitted with limitation of rotation angle make this JOHNSON CONTROLS actuator highly versatile.

Features

- DC 0(2)...10 V control signal
- Up to 5 actuators in parallel operation possible
- Plug-in terminal block connection
- Simple direct-mount with universal adapter on 10...20 mm Ø round-axis or 10...16 mm square shaft
- 48 mm minimum damper shaft length
- Selectable direction of rotation
- Limitation of rotation angle
- Manual release button
- 2 adjustable auxiliary switches
- Automatic shut-off at end position (overload switch)
- Actuators available with 1m cable
- Customized versions available
- Devices meet CE requirements

Accessories

- M9000- ZK Damper linkage selection
- M9000- ZKG Ball joints

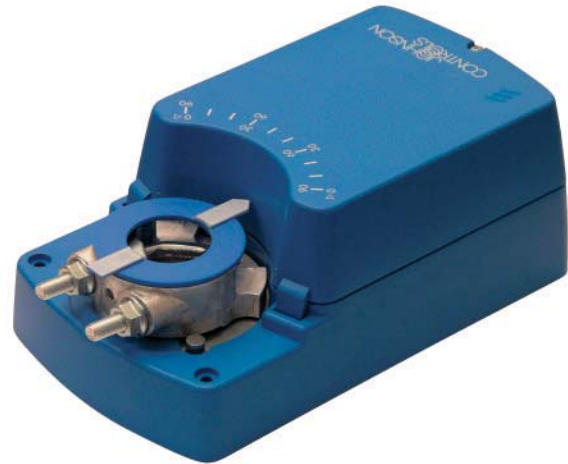

Ordering Codes

Codes	Descriptions
M91...-GDA-1N	AC 230 V
M91...-GDC-1N	AC 230 V, with 2 auxiliary switches
M91...-GD...-N-K	with 1 m halogen-free cable

Technical Specifications

Actuator	M9108-GD..	M9116-GD..	M9124-GD..
Torque	8 Nm	16 Nm	24 Nm
Damper area*	1.5 m ²	3.0 m ²	4.5 m ²
Running time OPEN	30...45 s	80...110 s	125...160 s
Running time CLOSE	30...45 s	80...110 s	125...160 s
Supply Voltage	AC 230 V		
Frequency	50-60 Hz		
Power Consumption	- Running 5.5 W - At end position 0.6 W		
Dimensioning	6.0 VA / 0.1 A @ 2 ms		
Weight	1.2 kg		
Control signal Y1	DC 0(2)...10 V		
Input resistance Y1	Ri 100 Ω		
Position signal U	DC 0...10 V		
Load resistance	>50 k Ω		
Angle of rotation/working range	90° (93 °mech.)		
Angle of rotation/limitation	5°...85° in 5°< steps		
Auxiliary Switches	3(1.5)A, AC 230 V		
- S1 setting range	5°...85°< adjustable		
- S2 setting range	5°...85°< adjustable		
Cable	1.0 m halogen-free		
- Motor	6-Wire 1-2-3-4-5-6		
- Switches	5-Wire 21-22-23-24-25		
Lifetime	60'000 Rotations		
Noise level	45 dB (A)		
Protection class	II		
Degree of protection	IP 54		
Mode of action	Type1		
Ambient conditions	- Operating temperature -20...+50°C / IEC 721-3-3 - Storage temperature -30...+60°C / IEC 721-3-2 - Humidity 5...95% r.F. no condensed		
Service	Maintenance-free		
Standards	- Mechanics EN 60 529 / EN 60 730-2-14 - Electronics EN 60 730-2-14 - EMC Emissions EN 50 081-1:92 / IEC 61000-6-3:96 - EMC Immunity EN 50 082-2:95 / IEC 61000-6-2:99		

Proportional Actuators AC 230 V
2.26 N

Wiring Diagram

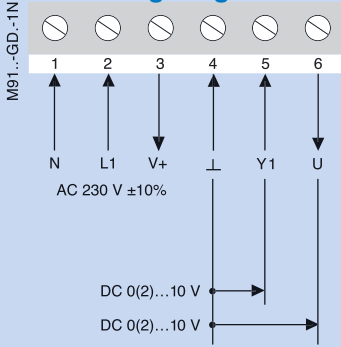

Parallel Connections

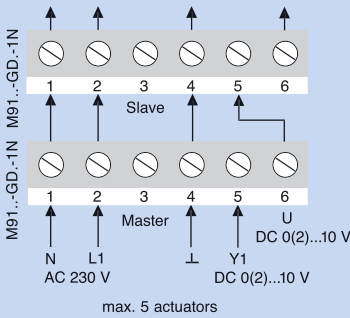

Position transmitter

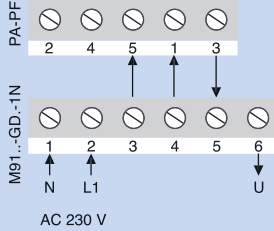

Auxiliary Switches (S)

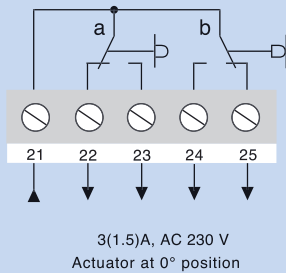

Override Control

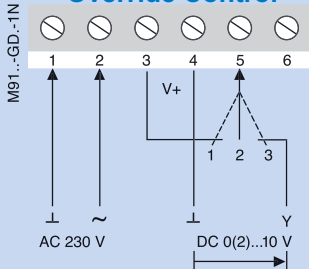

Dimensions in mm (inches)

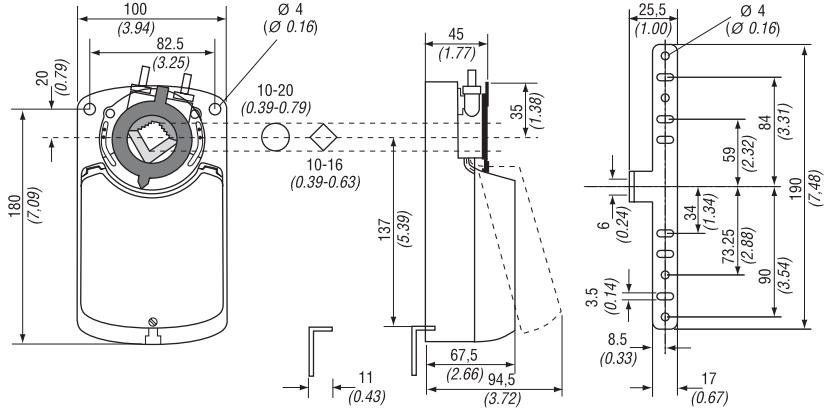

Setting the control Signal

Control signal Y1 DC 0(2)...10 V
Input resistance Ri 100 kΩ

Position signal U DC 0(2)...10 V
Load resistance > 50 kΩ

Switching microswitch d1 to the ON position will change the control signal to DC2...10 V

Microswitch d
DC 0...10 V

Microswitch c
DC 0...10 V

Changing the direction of rotation

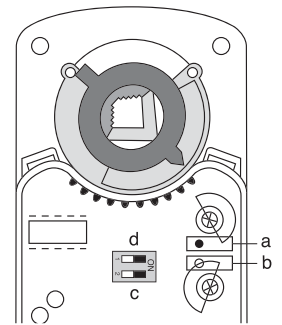

Position transmitter

The M91...GD.-1N can also be controlled using the JOHNSON CONTROLS Positioner (PA/PF) with control signal of DC 0(2)...10 V. For further information concern the PA and PF positioner please refer to sheet 6.20.

Caution: A maximum of 5 actuators can be controlled in parallel operation.

Setting the auxiliary switches

Factory setting:

Switch a at 10°
Switch b at 80°

The switching position can be manually changed to any required position by turning the ratchet.

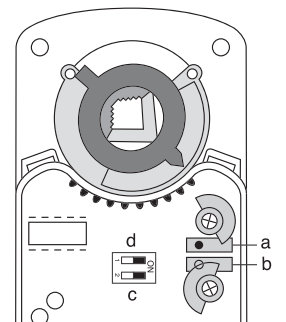

Override control

The actuator M91...GD.-1N can be forced to override control when wired in accordance with the relevant diagram on the left.

Switch position:
1 = Actuator runs at 10 V
2 = Actuator runs at 0(2) V
3 = Automatic control

Rotation Angle

The limitation or rotation angle can be set in 5° steps by moving the adapter.

The adapter can be removed simply by pressing the adapter clip on the underside of the actuator.

Limitation of rotation angle

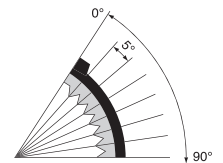

Adapter release

