



techsystem

automatyka klimatyzacja wentylacja

▸ zapoznaj się z naszą ofertą

**XT-9100 Extension Module
 XP-910x Expansion Modules**

Introduction	5
<i>Features</i>	7
<i>Model Codes</i>	7
Design Considerations	9
<i>Hardware Configurations</i>	9
<i>Analog Inputs</i>	10
<i>Digital Inputs</i>	12
<i>Digital Counters</i>	12
<i>Analog Outputs</i>	12
<i>Digital Outputs</i>	13
Installation	15
<i>General Guidelines</i>	15
<i>Mounting Instructions</i>	16
<i>Wiring</i>	16
Software Configuration	21
<i>Description of Items</i>	21
<i>Item Address</i>	21
<i>Item Type</i>	21
<i>Item Tag</i>	22
<i>Read/Write Data</i>	22
<i>XT-9100 Type Settings</i>	23
<i>Power Line Frequency (50 or 60 Hz)</i>	23
<i>User Name and Description (GX Tool Only)</i>	23
<i>XT Address</i>	23
<i>Maximum Time Between Communications</i>	23
<i>Operational Mode (SX Only)</i>	24

<i>XT-9100 Configuration Settings</i>	24
<i>Analog Input Configuration</i>	26
<i>AI User Name and Description (GX Tool Only)</i>	26
<i>AI: Input Signal and Range</i>	26
<i>AI: Measurement Units</i>	28
<i>AI: Enable Square Root</i>	28
<i>AI: Alarm on Unfiltered Value</i>	28
<i>AI: Alarm Limits</i>	29
<i>AI: Filter Time Constant</i>	30
<i>AI: Offset Value</i>	*30
<i>AI Notes</i>	30
<i>Binary (Digital) Input Configuration</i>	31
<i>DI User Name and Description (GX Tool Only)</i>	31
<i>DI: Input Type</i>	31
<i>DI: Counter Prescaler</i>	31
<i>DI Notes</i>	32
<i>Analog Output Configuration</i>	32
<i>AO User Name and Description (GX Tool Only)</i>	32
<i>AO: Output Type</i>	32
<i>AO: Source</i>	33
<i>AO: Range</i>	33
<i>AO Notes</i>	33
<i>Binary (Digital) Output Configuration</i>	34
<i>DO User Name and Description (GX Tool Only)</i>	34
<i>DO: Output Type</i>	34
<i>DO: Pulse Time</i>	34
<i>DO: Status on Comm. Failure</i>	35
<i>DO: Source</i>	35
<i>DO Notes</i>	36

*Indicates changes made in the document since the last release.

Specifications and Technical Data	37
<i>XT-9100-8304</i>	37
<i>TR-9100-8001 (Not available in North America)</i>	38
<i>XP-9102-8304</i>	38
<i>XP-9103-8304</i>	39
<i>XP-9104-8304</i>	39
<i>XP-9105-8304</i>	40
<i>XP-9106-8304</i>	40
<i>XP-9107-8304</i>	41
Commissioning and Troubleshooting	43
<i>XP-9102 Jumper Settings</i>	43
<i>XT-9100 Switch Settings</i>	44
<i>Power Up</i>	44
<i>LEDs</i>	44
<i>Supply Protection</i>	45
<i>Download/ Upload</i>	46
<i>Via the GX Tool</i>	46
<i>Via the SX Tool</i>	47
Appendix A—Item Table	49
<i>Items</i>	49
<i>Item Types</i>	49
<i>Floating Point Numbers</i>	49
<i>Item Table</i>	*50

*Indicates changes made in the document since the last release.

Introduction

The XT-9100 Extension Module and XP-910x Expansion Modules have been designed to provide additional input and output capacity within Metasys networks, specifically for the DX-9100 and DX-912x (LonWorks) Extended Digital Plant Controllers. The XT-9100 module provides the communications interface, and the XP modules provide the analog and digital inputs and outputs.

A Supervisory System communicates with the XT-9100 via the N2 Bus. See *Figure 2: General Application*. Each XT-9100 can have up to 16 inputs/outputs, eight of which may be analog.

The DX controller communicates with the XT-9100 via the XT-Bus. When the DX controller is connected to the N2 Bus, data from the XT-9100 is available to a Supervisory System. See *Figure 3: DX-9100/DX-912x Application*. Up to eight XT-9100 modules can be connected to the XT-Bus. Each XT-9100 provides, depending on the type of the connected XP expansion modules, eight analog or eight digital points, extending the input/output of a DX controller by up to 64 remote input/outputs. Modules with 16 input/outputs may also be connected, provided that the total number of remote input/output points on the DX controller does not exceed 64.



Figure 1: XT-9100 Extension Module and XP-910x Expansion Modules

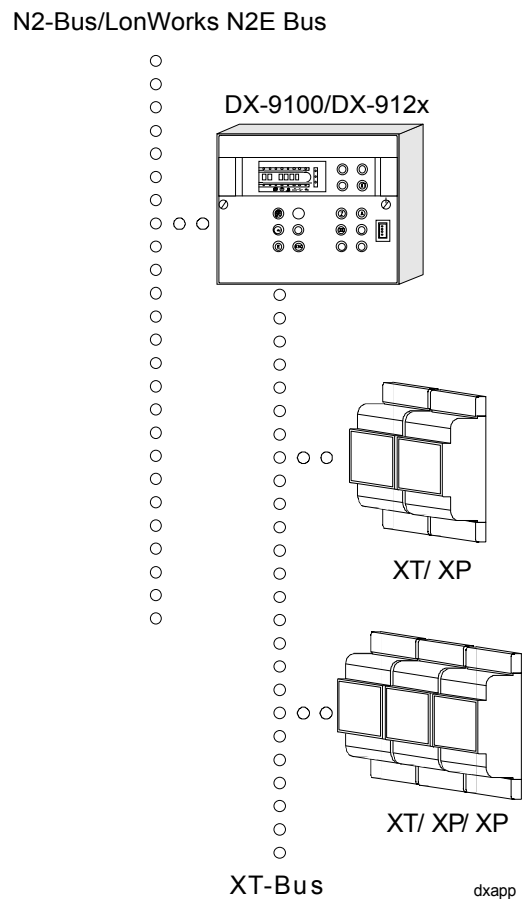
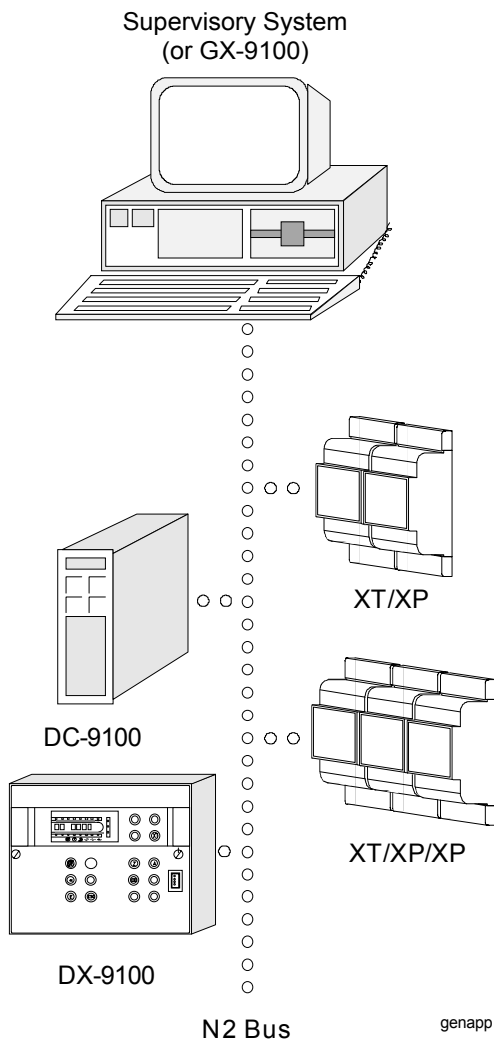

Figure 2: General Application

Figure 3: DX-9100/DX-912x Application

Configuration of the XT-9100 is achieved by using a personal computer with GX-9100 Graphic Configuration Software (GX Tool) supplied by Johnson Controls. When the serial interface of the XT-9100 is connected directly to an N2 Bus, the GX-9100 downloads and uploads configurations over the N2 Bus. When the serial interface of the XT-9100 is connected to the XT Bus of a DX controller, the GX-9100 downloads and uploads configurations via the DX which retransmits configuration data to the XT-9100 on its XT-Bus.

The XT-9100 may also be configured item by item, using an SX-9120 Service Module (SX Tool) connected to the DX controller.

Table 1: Related Information

Description	Document
Downloading and uploading via the DX controller	<i>DX-9100 Configuration Guide (MN-9100-4103)</i>
Configuring the XT module	<i>GX-9100 Software Configuration Tool for Windows (MET-CTW-05); SX-9120 User's Guide (MN-9100-6103)</i>

Features

- Range of I/O submodules (XPs) for flexible configuration of 4, 8, 12, or 16 data points.
- Analog inputs 0 to 10 V, 0/4 to 20 mA, or RTD.
- Analog outputs 0 to 10 V, or 0/4 to 20 mA.
- Digital inputs with digital counter option.
- Digital outputs; triacs or relay contacts.
- I/O data point configurable by using GX-9100 Graphic Configuration Software.
- Communications bus (RS-485) for Supervisory System/GX-9100.
- LED status indicators.
- Transformer module for 230 VAC supply.
- Enclosure material of self-extinguishing ABS polycarbonate.
- DIN rail mounting.

Model Codes**Table 2: XT/XP/TR Model Codes**

XT-9100-8304	Extension Module	24 VAC supply
XP-9102-8304	Expansion Module	6 analog inputs 2 analog outputs
XP-9103-8304	Expansion Module	8 digital outputs (triacs)
XP-9104-8304	Expansion Module	4 digital inputs 4 digital outputs (triacs)
XP-9105-8304	Expansion Module	8 digital inputs
XP-9106-8304*	Expansion Module	4 digital outputs (relay)
XP-9107-8304	Expansion Module	4 digital outputs (relay - 24 VAC only)
TR-9100-8001*	Transformer, 24 V/12 VA	Primary: 230 VAC
* Not available in North America.		

Design Considerations

Hardware Configurations

An XT-9100 combined with expansion modules provides the following configurations:

- Eight analog inputs/outputs.
- or • Eight digital inputs/outputs, with digital counters associated with the digital inputs.
- or • Eight analog inputs/outputs and eight digital inputs/outputs.
- or • 16 digital inputs/outputs, with digital counters associated with the digital inputs within the first eight inputs/output points.

The **extension module address** is set with the address switches on the XT-9100. When connected to a DX controller, the address must be unique not only on the XT-Bus, but also on the N2 Bus to which the DX controller is connected.

The XT-9100 must be supplied with a 24 VAC power source. All models are suitable for 50 Hz or 60 Hz through software configuration.

For the analog inputs and outputs, the **input and output type** are set by jumpers on the analog expansion module board. These settings must comply with the software configuration settings.

Note: When an extension module is configured with 16 inputs/outputs, the DX controller considers the single physical module as two logical modules, each with eight inputs/outputs. The DX controller can communicate with up to eight logical modules, with a maximum of 64 inputs/outputs.

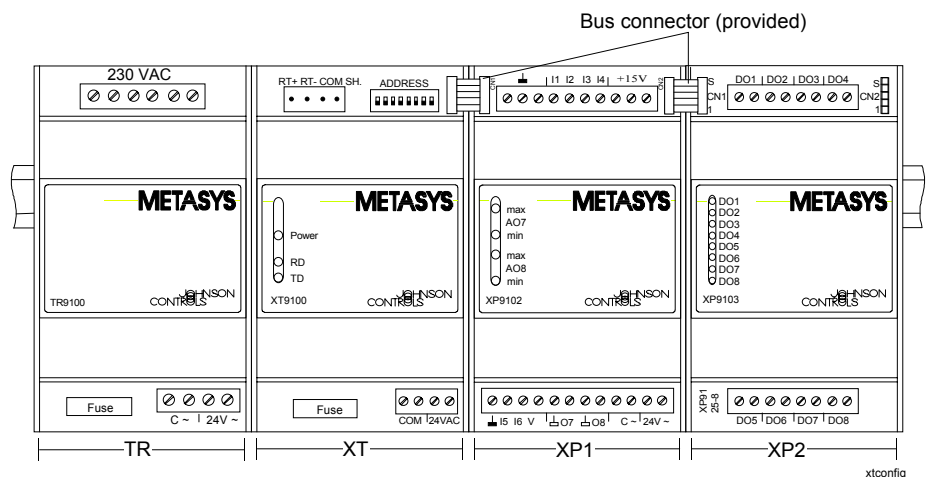

Figure 4: Typical XT-9100 Configuration

Table 3: XT Configurations

TR	Transformer	TR-9100-8001 (Not available in North America)	(optional)
XT	Processor	XT-9100	
XP1	Analog or Digital (See Note 4)	XP-9102 XP-9103 XP-9104 XP-9105 1 or 2 x XP-9106*	(See Note 1) (See Note 2)
XP2	Digital	XP-9103 XP-9104 XP-9105 1 or 2 x XP-9106*	(optional) (optional) (optional) (optional) (See Notes 2 and 3)

*XP-9107 in North America

Notes:

1. The analog XP-9102 must be placed in Position XP1.
2. Two XP-9106 modules are considered as one XP module when installed next to each other in Position XP1 or XP2. The first XP-9106 in position XP1 or XP2 controls points DO1-DO4 and the second XP-9106 controls points DO5-DO8.
3. The XP-9106 can only be placed in Position XP2 when Position XP1 is filled by an analog XP. A maximum of two XP-9106 modules may be installed in one XT configuration for CE Compliance. (When more than eight relays are required, use the XTM-905 and XPE-444 modules, or take further suitable measures to protect against EMC.)
4. Digital modules with counters must be in position XP1.

Analog Inputs

Expansion modules with analog inputs accept 0 to 10 V, 0 to 20 mA, or passive RTD sensors by jumper configuration. For 0 to 20 mA DC inputs, a zero offset to 4 mA may be set by software configuration. The measurement unit of each RTD input can be configured for degrees Celsius or degrees Fahrenheit. Voltage and current inputs can be ranged using the programmable range parameters as follows:

Lower end of range (LR) for 0 V/ 0 mA/ 4 mA

Higher end of range (HR) for 10 V/ 20 mA

Voltage and current inputs from differential pressure sensors can be linearized by a square root function that operates over the complete range of the input:

$$AI = [\text{sqrt}(\text{PR}\%/100)] \times (\text{HR} - \text{LR}) + \text{LR}$$

Where PR% = the analog value in percent of the physical range (0 to 10 V, 0 to 20 mA, 4 to 20 mA).

A configurable filter is incorporated for the reduction of signal instability. The filter function is:

$$FV_t = FV_{t-1} + \frac{1}{1+T_s} (AI_t - FV_{t-1})$$

where: FV_t = Filtered Analog Value at Current Time
 FV_{t-1} = Filtered Analog Value at previous poll
 AI_t = Actual Analog Value at current time
 T_s = Filter Time Constant (seconds)

A T_s value of “0” disables the filter.

Expansion modules with analog inputs will accept Ni1000 (JCI type), Pt1000, and A99 passive RTD sensors. For these sensors, the measurement range is fixed for each input type.

Table 4: RTD Sensor Measurement Ranges

RTD Sensor	Range
Ni 1000 Regular Sensor (JCI)	-45 to +121 °C/-50 to +250 °F
Ni 1000 High Temperature Sensor (JCI)	+21 to +288 °C/+70 to +550 °F
Platinum 1000 (DIN) Sensor	-50 to +200 °C/-58 to +392 °F
A99 Sensor (JCI)	-50 to +100 °C/-58 to +212 °F

Expansion modules with analog inputs provide a 15 VDC supply for analog input sensors. *The maximum current supplied from this power supply must not exceed 30 mA.*

A high and low alarm limit setting with alarm limit differential can be assigned to each analog input.

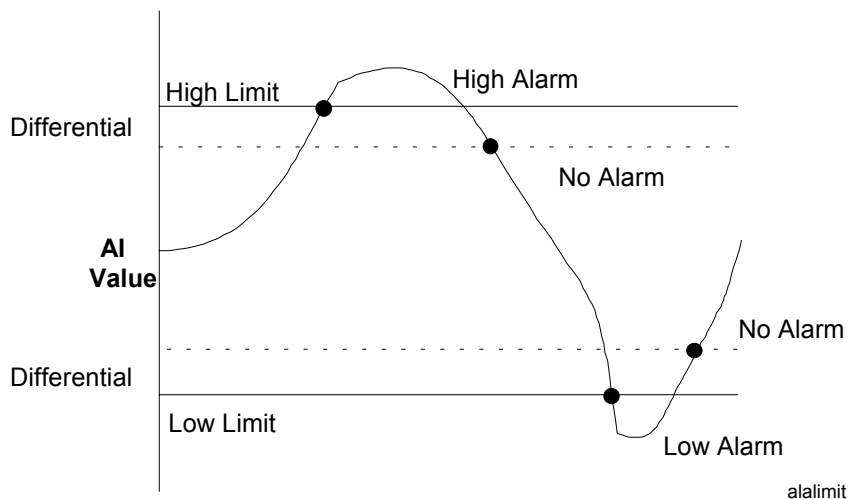

Figure 5: How Alarm Limits Function

When connected to a DX controller, each analog input value can be assigned to any of the 12 programmable function modules, and high and low alarms are available as logic variables.

Digital Inputs

A digital input is active when connected to the digital input common via an external potential-free contact.

A digital input may be defined as maintained or pulse type by configuration. With maintained type contacts, the extension module status follows the status of the contact. With pulse type contacts, the extension module sets and resets the status at each pulse of the input contact.

The status of each input on a digital expansion module is indicated by an LED.

When connected to a DX controller, each of the digital inputs can be assigned to any of its 12 programmable function modules, or to its programmed logic control module.

Digital Counters

Digital counters are available on modules with digital inputs when installed in the first expansion module position (XP1). The number of transitions of the physical digital input required to increment the counter can be set in the extension module. Counter values are stored in a four-byte RAM memory location, and on power failure are automatically saved in EEPROM and restored to RAM when power returns. The maximum value of each counter displayed on the DX controller is limited to 9,999,999.

Analog Outputs

Expansion modules with analog outputs provide 0 to 10 V or 0 to 20 mA outputs by jumper configuration (*see Figure 17: Jumper Details for the XP-9102*), and a 4 mA zero offset by software configuration.

Each output level on the XP-9102 is indicated by two LEDs, one for 0% and one for 100%. The LEDs are equally bright at 50% output. Analog outputs have a fixed range of 0 to 100% in the expansion module.

When connected to a DX controller, the outputs can be connected to the outputs of its programmable function modules.

Digital Outputs

The physical output may be a triac or a relay contact.

Each digital output can be configured to provide one of the following output types:

- On/off

The triac or relay is switched on or off in accordance with the digital output command. On power failure the triac will go off, and on power restoration will remain off until commanded on. On XT Bus/N2 Bus communication failure, the output will be switched off or remain in its current state, depending on the software configuration.

- Pulse

The triac or relay is switched on for a configurable period (0 to 1250 ms) for each state transition of the digital output command.

The status of each output on a digital expansion module is indicated by an LED.

When connected to a DX-9100 controller, the digital outputs may be driven by any logic variable or output of the programmable function modules, programmable logic module, or time schedule modules.

Installation

General Guidelines

While every reasonable precaution has been taken to prevent electrical disturbances from adversely affecting the operation of modules, lack of attention to generally accepted control wiring installation practices can lead to module problems in high electromagnetic field environments. In general, follow the guidelines below.

- Do not mount the modules in heavy-duty switch gear cabinets or in cabinets with frequency converting or phase-cutting equipment.
- Low-voltage wiring in electrical cabinets must be physically separated from line-voltage and power wiring, and a distinctive color (e.g., white or pink) is recommended.
- To avoid electrical interference in field cables:
 - Keep input and output point cable runs as short as possible (<50 m/160 feet).
 - Use twisted pair cables.
 - Run low-voltage cables separately from line-voltage/power cables. Maintain a minimum separation of > 30 cm/12 in for 220 V 30 A circuits.
 - Do not run low-voltage cables parallel to power cables for long distances (>3 m/10 feet).
 - Do not run cables close to transformers or high frequency generating equipment.
 - In high electromagnetic field environments, use shielded cable, grounding the shield at one end, preferably to the modules cabinet only.
 - For the communication bus (N2 Bus) and extension module bus (XT-Bus) use a cable recommended for RS-485 transmission. The cable must be shielded and grounded at one end only. (See the technical bulletin on the Metasys N2 Bus.)
- If a TR-9100 transformer is used for the XT-9100 and the XPs, an additional supply should be used for the external devices. Do not connect switched inductive loads to the 24 V transformer that supplies the modules, and cable each connected load from the transformer separately.

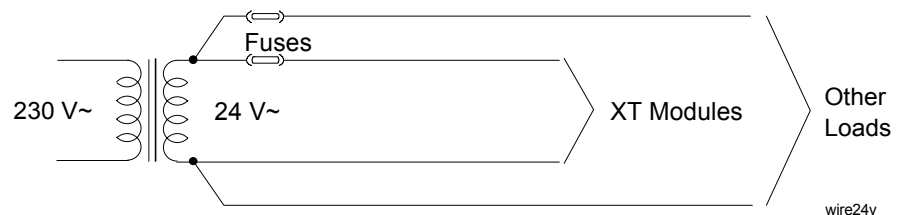

Figure 6: Wiring of Module to a 24 V Transformer

Mounting Instructions

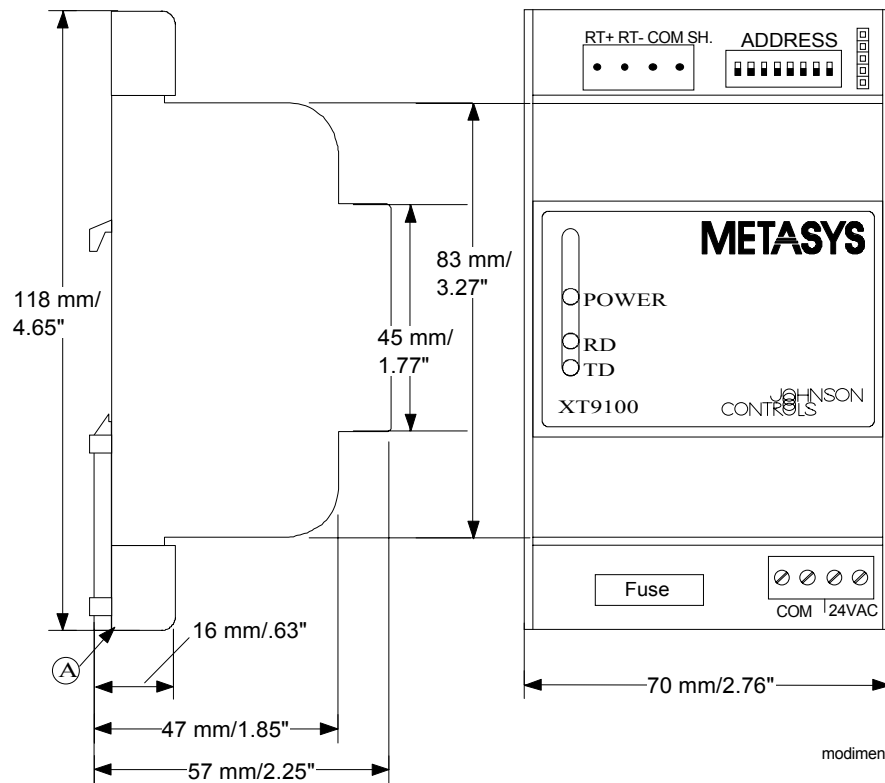



Figure 7: Module Dimensions

Snap the module onto the 35-mm/1 3/8-inch DIN rail. To release the module, insert a screwdriver at the base of the module (A) to release the retaining clip and pull forward. *Or* lift the module upwards against the spring of the retaining clip and pull forward from the top.

Wiring

 **CAUTION:** Connections to the terminals of XP-9106 and TR-9100 may carry up to 250 VAC. Isolate both live and neutral lines (double-pole switch) before servicing.

1. Remove the translucent terminal covers before connecting wires. If the modules are installed in a metal cabinet which is connected to an earth ground, the covers may be discarded. Otherwise, replace the covers when the wiring has been completed.

Terminations are made via the terminal blocks on the upper and lower parts of the modules that accept 1 x 1.5 mm²/16 AWG cable. See *figures 8 to 15* for details.

2. Terminations of the serial link bus cable are via the connectors provided with the XT-9100 module.
3. Interconnections between XT and XP modules for the expansion bus are via the connector cables provided with each XP module.

4. Complete all wiring and connections to the XT and XP modules before applying power. The XT processor will then automatically set its communication buffers for the connected XPs.



CAUTION: The CMOS integrated circuits in the modules are sensitive to static. Take suitable precautions.

Legend for Figures 8-15

In	Analog input signal
	Analog input common
On	Analog output signal
	Analog output common
DIn	Digital input
C	Digital input common
DOn	Digital output (triac)
C~	24 VAC common
Rn	Relay output common
NO	Normally open contact
NC	Normally closed contact

Notes:

1. Loads connected to digital outputs should be supplied from a separate, properly sized transformer and not from the TR-9100 transformer.
2. The following commons are electrically independent:
 - Analog Input Common (for AI1 to 6)
 - Analog Output Common (for AO7 and 8)
 - 24 V Common/Digital Input Common (for DI1 to 8)
 - Communications Common (N2 Bus / XT-Bus)

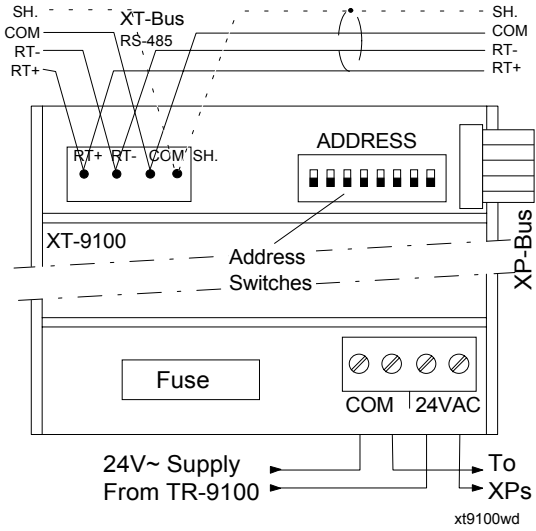

Figure 8: XT-9100

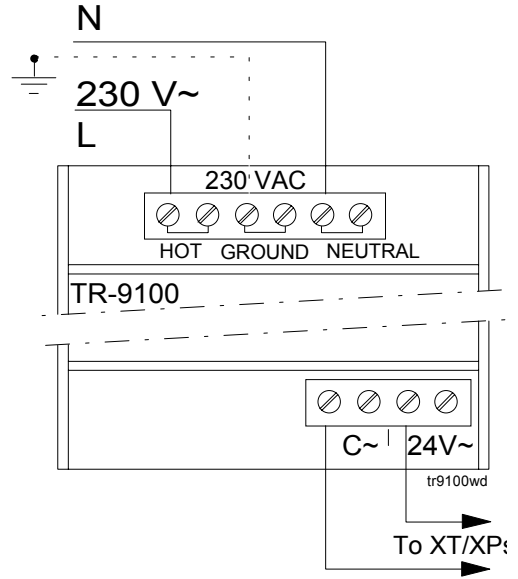

Figure 9: TR-9100

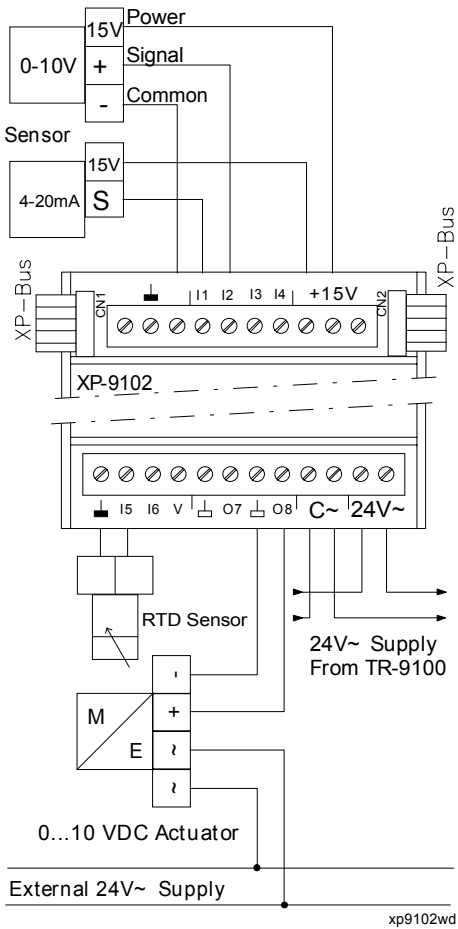

Figure 10: XP-9102

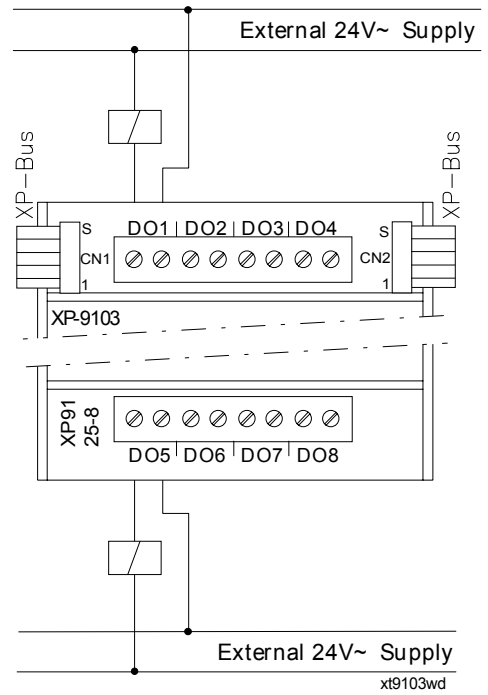

Figure 11: XP-9103

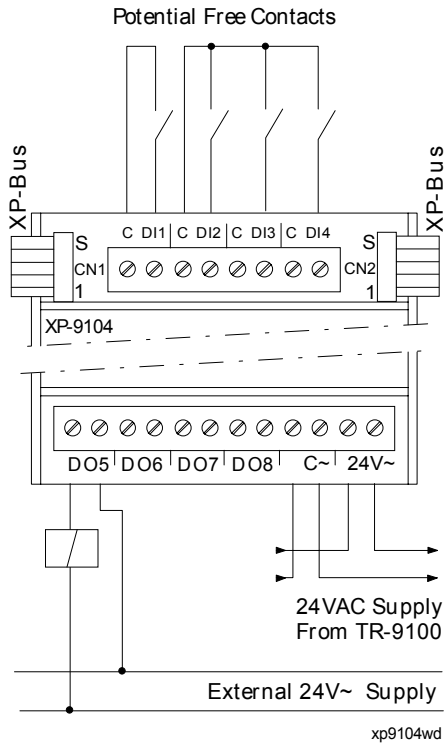

Figure 12: XP-9104

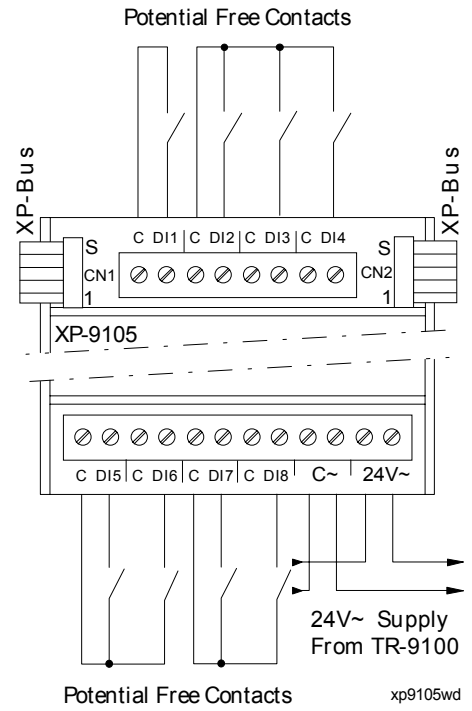

Figure 13: XP-9105

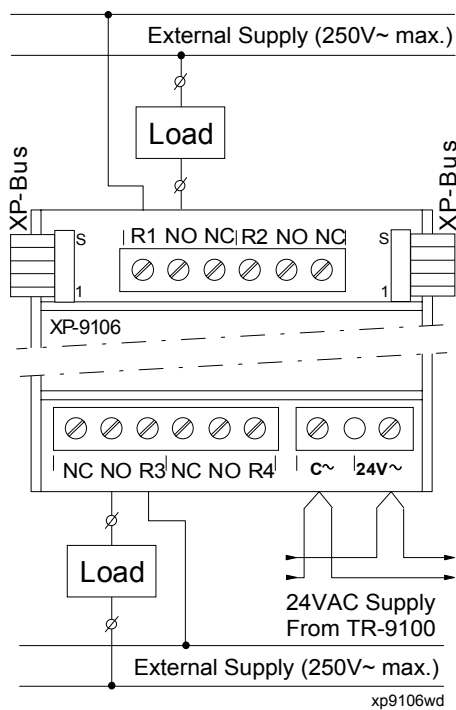

Figure 14: XP-9106*

*Not available in North America.

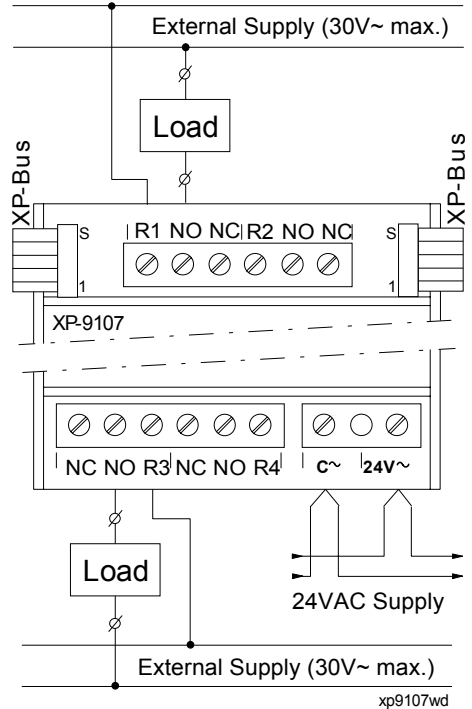

Figure 15: XP-9107**

**Available only in North America.

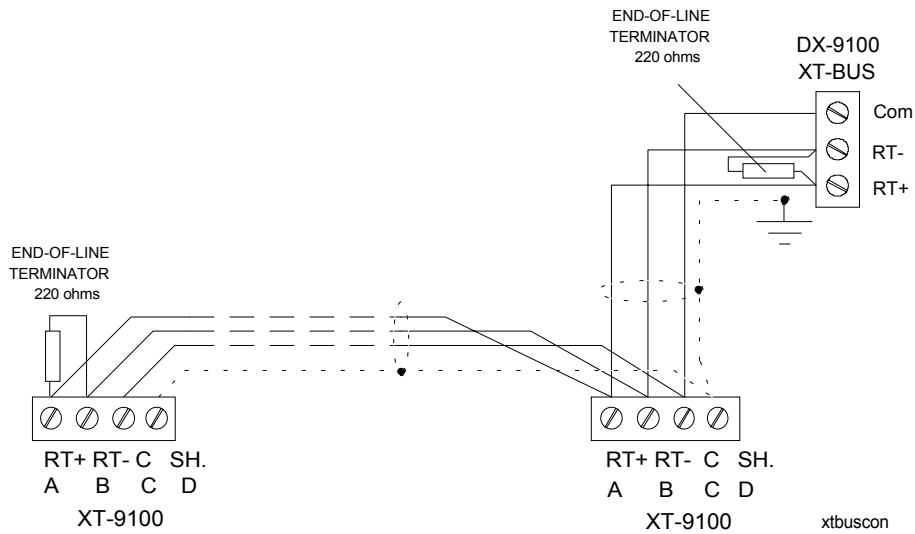

Figure 16: Connection Details For The XT-Bus

XT-Bus Guidelines:

1. Maximum: 8 x XT-9100 per DX-9100.
2. Maximum bus length: 1200 meters/4000 feet.
3. When the bus length is greater than 100 meters/330 feet, install 220-ohm end-of-line resistors at each end of the XT-Bus line. When the bus length is less than 100 meters/330 feet, install a 220-ohm end-of-line resistor at the DX-9100 only.
4. The end-of-line-resistor is provided in the Version 1 DX controller and is connected by jumper JP7. For Version 2 and LonWorks® DX controllers, the end-of-line resistor is provided in the mounting base or frame. Refer to the *DX-9100 Technical Bulletin (MN-9100-2110)* for details.

Software Configuration

Software configuration of the XT-9100 Extension Module is done as part of the DX controller configuration process, using the GX-9100 Graphic Configuration Software (GX Tool). Refer to the *GX-9100 Software Configuration Tools for Windows User's Guide (MET-CTW-05)* in the *Configuration Tools for Windows Manual (MET-CTW)* for full technical and operating details. This section explains the configuration process for users wanting to understand the XT data base structure in more detail, and also gives information on how to verify and change the configuration using the SX Tool.

Description of Items

A configuration consists of a set of parameters which are stored in specific memory locations in the XT-9100. These memory locations are addressed and referenced using mnemonic names called Items. Each Item represents a specific memory location (address) and is of a specific type corresponding to its usage and the number of bytes of memory it represents.

Dynamic (changing) data, such as analog values, are stored in RAM. Configuration parameters are stored in EEPROM. Data stored in EEPROM is retained when the power is switched off.

The *Item Table* in *Appendix A* of this document gives a brief description of all of the Items available within the module.

Item Address

The address of each Item is shown in the **ADDRESS** column of the *Item Table* in both decimal and hexadecimal representation in the **Dec.** and **Hex.** subcolumns, respectively. In order to make it easier to find the Items in the table, the decimal Item Address is shown in parentheses throughout the rest of the configuration section, e.g., Item *XTS (dec. 69)*.

Item Type

The information stored in the Items can have one of several formats:

- a) **Floating Point Numerical Items** are real numbers, with a \pm sign and decimal point. They refer to input or output values, limit values, etc. They are displayed and entered as numbers, with a sign and decimal point. These Items are shown in the *Item Table* with “*Float*” in the **TYPE** column.
- b) **Integer Items** are positive whole numbers used as scale factors. These Items are shown in the *Item Table* with “*1 Byte*” in the **TYPE** column. Some integer values may be 2 bytes long, which is indicated in the *Item Table* with “*2 Bytes*” in the **TYPE** column.

- c) **Totalized Numerical Items** are positive whole numbers. They refer to totalized values of pulse counters. They are displayed and entered as whole numbers without a sign or decimal point. These Items are shown in the *Item Table* with “4 Bytes” in the **TYPE** column.
- d) **Status Items** are either 8- or 16-bit (1- or 2-byte) Items giving information on the current status or configuration of the inputs, outputs, and modules. Each bit of the Item has a specific meaning as described in the *Item Table*. These Items are shown in the *Item Table* with “8-bits” or “16-bits” in the **TYPE** column. In the table, the bit positions will be referenced using X8-X1 or X16-X1, and a line depicting the bit positions will be shown, as follows:

1 Byte = X8 X7 X6 X5 X4 X3 X2 X1
 2 Bytes = X16 X15 X14 X13 X12 X11 X10 X9 X8 X7 X6 X5 X4 X3 X2 X1

Item Tag

Each Item in the *Item Table* has a unique name or “Tag” of up to five characters, which is a mnemonic for the type and usage of the data stored at that memory location in the XT-9100.

The Items are shown in the *Item Table* with their mnemonic names in the **TAG** column.

Read/Write Data

The Items shown in the *Item Table* fall into three basic categories:

- a) Input values and status Items of the XT-9100 which can be read but not changed by a supervisory system. These Items are shown in the *Item Table* with an “R” in the **R/W** (read/write) column.
- b) Variables in the XT-9100 which can be read and modified by Configuration Software or supervisory systems. These Items are shown in the *Item Table* with an “R/W” in the **R/W** (read/write) column. The “R/W” may be followed by “(E)”, which indicates that the Item is stored in EEPROM and can only be written approximately 10,000 times.
- c) All other Items in the XT-9100 refer to configuration parameters of the module and contain information such as analog ranges, output type, etc. These Items should only be changed with the GX-9100 Graphic Configuration Software (GX Tool) or SX Tool, and are indicated in the *Item Table* with “CNF” in the **R/W** (read/write) column. All configuration parameters are stored in EEPROM and the restriction of approximately 10,000 write operations applies here also.

XT-9100 Type Settings

Power Line Frequency (50 or 60 Hz)

Via the GX Tool

Select Edit and then Global Data. Enter the frequency as 50 or 60. The XT frequency and the DX frequency are both defined here.

Via the SX Tool

Set Bit X1 of Item XTS (dec.69).

X1 = 0 50 Hz power line

X1 = 1 60 Hz power line

User Name and Description (GX Tool Only)

Via the GX Tool

First configure an XT module. Select PM, XTn, and an analog or digital configuration.

Then select the just configured XTn and Data. Enter as appropriate:

User Name (maximum 8 characters)

Description (maximum 24 characters)

XT Address

Via the GX Tool

In order to download the XT-9100 modules it is necessary to enter the XT addresses. When performing a download through a DX controller, these addresses will also be loaded into the DX, and the controller will retransmit XT data to its own XT set. The XT address is not stored in the XT-9100, but must be set on the address switches on the module.

First configure an XT Module. Select PM, XTn, then an analog or digital configuration. Then select the just configured XTn and Data. At the “Hardware Address” field, enter the address (1-255) of the XT-9100 module.

Via SX Tool

Refer to *Extension Module Configuration* in the *DX-9100 Configuration Guide*.

Maximum Time Between Communications

When communication fails for the period set in this Item, the XT-9100 goes into “communication failure” state, indicated by a blinking Power LED on the front of the module. The default value is 60 seconds.

Via the GX Tool

First configure an XT module. Select PM, XTn, and an analog or digital configuration. Then select the just configured XTn and Data. At the “Comm. timeout (sec)” field, enter the value in seconds.

Via the SX Tool

The **Maximum Time Between Communications** (in seconds) is entered at Item MTBC (dec.86).

Operational Mode (SX Only)

The operational mode of the XT-9100 can be seen at Item OPMO (dec.01) with following status bits:

X8 = 1 PWR Power Failure. This bit is set when an XT is powered up or when there is a serial interface communication failure.

The setting in Item XTS (dec.69) Bit X2 (“Output Hold/Reset on Communication Failure” flag) is repeated in Item OPMO (dec.01) Bit X7 (FAIL) so that it can be read by the DX controller. Both of these operational mode status bits are available in the DX data base.

XT-9100 Configuration Settings

Via the GX Tool

The I/O type and map details are automatically generated by the GX-9100 Graphic Configuration Software when all I/O data for extension modules has been entered. It is then downloaded into the XT-9100 via the DX controller and XT-Bus. (Refer to the *Download/Upload* section, further in this document.)

When in the GX Tool, select PM, XT, and an analog or digital configuration. If digital, define the module as 4DI4DO, 8DI, or 8DO. If analog, define it as 6AI2AO. This defines Module XP1. If an XT has 16 points (XP2 is connected), select PM, XT again and define it as EXP.4DI4DO, EXP.8DI, or EXP.8DO. EXPn will appear in the box on screen. The configured points will appear to the left and right of the screen. Refer to *Table 5* below for the appropriate selections for the available XP modules. Then define each point in the selected configuration in the same way as when defining the points in the DX controller. The following pages describe how to define each of the points individually.

Table 5: GX Tool Selection for Module Configuration

XP Modules	GX Tool Selection
XP-9102	6AI2AO
XP-9104	4DIDO
XP-9106/7	8DO (Configure DO1-DO4 only.)
2 x XP-9106/7	8DO
XP-9103	8DO
XP-9105	8DI

Via the SX Tool

Each extension module configuration is defined by the I/O types and map which are configured in Extension Module Items **IOMAP** (dec.77), **IOTYP** (dec.78) and **IOMOD** (dec.79).

- a) The **I/O map** (IOMAP) defines which inputs/outputs (in pairs) on the extension module are used. Each extension module can be defined with eight used points which normally reside in the XP1 (first) Expansion Module (points I/O1-I/O8), defined in bits X1-X4.
When an extension module has an XP2 (second) Expansion Module with a further eight points, these points must be defined in bits X5-X8.
- b) The **I/O type** (IOTYP) defines which inputs/outputs (in pairs) are analog and which are digital. As the points on XP2 (if used) must be digital, only bits X1-X4 can be configured.
- c) The **I/O mode** (IOMOD) defines points as "input" or "output" (in pairs). Only those points declared as "used" in Item IOMAP will be monitored or controlled.

The combination of data in the Items IOMAP, IOTYP and IOMOD completely defines the configuration of an extension module. When connected to a DX controller, an identical set of data must be entered into the Item data base in the DX controller, so that, when the DX and XT-9100 are connected and started up, the DX will compare data bases and only send commands to the extension module if the data is identical, thus avoiding incorrect control actions.

Note: The data base in the XT-9100 has been designed to accept most configuration of inputs and outputs. **All inputs and outputs which are physically connected through expansion modules must be configured, and only those points.** If there is a difference between the physical configuration and the software configuration the XT-9100 will signal an error condition to the DX controller:

XTnERR = Wrong hardware configuration.

XTnHARD = Hardware not connected or not responding.

Analog Input Configuration

Each analog input is defined and configured by the following parameters:

- User name and description (GX Tool only)
- Input signal and range
- Measurement units (for RTD inputs)
- Enable square root
- Alarm on unfiltered value
- Alarm limits
- Filter time constant

The GX Tool determines the input signal range with a two-step process: you must first decide if the input is active or passive; the remaining options depend on this choice. With the SX Tool, this information is entered into a number of Items.

Via the GX Tool

Select XTnAIn, then Active or Passive.

Note: All AI points must be configured even if not connected to a sensor to enable the generation of a complete IO Map and to ensure correct operation with the DX controller.

AI User Name and Description (GX Tool Only)

Via the GX Tool

Select XTnAIn and then Data. Enter as appropriate:

User Name (maximum 8 characters)

Description (maximum 24 characters)

AI: Input Signal and Range

Via the GX Tool

(You must first have selected whether the input is active or passive. See the beginning of *Analog Input Configuration*.)

For **active** inputs, select XTnAIn and Data. At the “Type of Active Input” field, enter:

0 = 0-10 VDC

1 = 4-20 mA

2 = 0-20 mA

Each analog input module channel performs the conversion of the input signal to a numeric value using the high range and low range.

High Range = enter the equivalent number for reading at high input (10 V, 20 mA).

Low Range = enter the reading at low input (0 V, 0 mA, 4 mA).

For **passive** inputs, select XTnAIn, then Data. At the “Type of Passive Input” field, enter:

- 1 = Ni1000 (JCI Type)
- 2 = Ni1000 Extended Range
- 3 = A99 (JCI Type)
- 4 = Pt 1000 (DIN)

For all RTD inputs, the range of the displayed value is fixed according to the type of sensor.

Via the SX Tool

The **input signal and range** for the eight possible inputs (n = 1 to 8) can be configured in Item AITn (dec. addresses 88, 96, 104, 112, 120, 128, 136 and 144).

Input type:

X7 = 0	0-10 Volts
X7 = 1	0-20 mA or RTD
X8 = 1	20 % Suppression (2-10 V or 4-20 mA)

Linearization and Sensor Type:

X12 X11 X10 X9 = 0000	Linear (Active Sensor)
X12 X11 X10 X9 = 0001	Ni 1000 RTD Regular Sensor (JCI)
X12 X11 X10 X9 = 0010	Ni 1000 RTD High Temperature Sensor
X12 X11 X10 X9 = 0011	RTD Sensor A99 (JCI)
X12 X11 X10 X9 = 0100	RTD Sensor Platinum 1000 (DIN)

Note: For RTD Sensor Measurement Ranges, refer to *Table 4*.

Each analog input channel performs conversion of the input signal to a raw value as a function of factory set calibration constants.

For active inputs, a numeric value expressed in engineering units is then obtained using the input's **high range** at Items HRn (n = 1-8 at dec. addresses 89, 97, 105, 113, 121, 129, 137 and 145) and the input's **low range** at Items LRn (n = 1-8 at dec. addresses 90, 98, 106, 114, 122, 130, 138 and 146).

For RTD inputs, the range of the temperature value is fixed according to the type of sensor and the units of measurement.

AI: Measurement Units

Via the GX Tool

The selection of Celsius or Fahrenheit, is set in the Global Data of the DX controller (select Edit, then Global Data. At the “Temperature Units” field, select Celsius or Fahrenheit).

To set the measurement units of active inputs, select XTnAIn, Data, and then enter in the “Measurement Units” field:

0 = None

1 = Temperature (“C” or “F” as entered in Global Data)

2 = Percent (%)

Note: The units of an active input are not only used by the Version 1 DX-9100 Controller for the front panel display, but may also be entered for informational purposes.

Via the SX Tool

Select Item AITn.

The unit of each analog input can be selected with the following bits: (For RTD inputs Celsius or Fahrenheit must be selected.)

X4 X3 X2 X1 = 0000 No Units

X4 X3 X2 X1 = 0001 Celsius

X4 X3 X2 X1 = 0010 Fahrenheit

X4 X3 X2 X1 = 0011 Percent

Changing individual temperature units for each AI can only be done using the SX tool.

AI: Enable Square Root

This function allows the linearization of a differential pressure signal from a 0-10 VDC or 0/4-20 mA active sensor.

Via the GX Tool (Option Only Available with Active Sensor)

Select XTnAIn and Data. At the “Square Root” field, enter “0” for No, or “1” for Yes (to enable the square root calculation).

Via the SX Tool (Operative Only with Active Sensor)

Select Item AITn.

X5 = 1 Enable Square Root of Input

X5 = 0 Disable Square Root of Input

AI: Alarm on Unfiltered Value

An alarm from the High Limit (HIA_n) and Low Limit Alarm (LOA_n) values may be generated from the unfiltered or filtered input. (See *Filter Time Constant* further in this document.)

Via the GX Tool

Select XTnAIn and Data. At the “Alarm Unfiltered” field, enter “0” for No (Alarm on Filtered Value), or “1” for Yes (Alarm on Unfiltered Value).

Via the SX Tool

Select Item AITn.

X6 = 0 Alarm on Filtered Value

X6 = 1 Alarm on Unfiltered Value

AI: Alarm Limits

The **high limit** and the **low limit** define at which levels the analog input reading will generate an alarm, either for remote monitoring or for internal use within the control sequences in the DX controller.

Note: The limits cannot be deleted. If you do not want alarms, enter limits beyond the range.

Via the GX Tool

Select XTnAIn, then Data. At the respective field, enter the limit:

High Limit = enter value at which input should go to high alarm.

Low Limit = enter value at which input should go to low alarm.

Limit Differential = enter value by which the input must change below the high limit or above the low limit to reach the normal state.

Via the SX Tool

The **high limits** at Items HIA_n (n = 1-8 at dec. addresses 91, 99, 107, 115, 123, 131, 139 and 147) and the **low limits** at Items LOA_n (n = 1-8 at dec. addresses 92, 100, 108, 116, 124, 132, 140 and 148) define at which levels the analog input reading will generate an alarm for remote monitoring purposes. These Items may also be set via the DX controller by a supervisory system, with the restriction that they are stored in EEPROM and can only be written approximately 10,000 times.

By setting bit X6 of Items AIT_n (dec. addresses 88, 96, 104, 112, 120, 128, 136 and 144) to “1”, the alarm will be generated from the unfiltered input.

The **differentials** on alarm limits are adjustable with Items ADF_n (n = 1-8 at dec. addresses 93, 101, 109, 117, 125, 133, 141 and 149).

AI: Filter Time Constant

The **Filter Time Constant** T_s (seconds) is used to filter out any cyclic instability in the analog input signals.

Via the GX Tool

Select XTnAIn, and Data. At the “Filter Constant (sec)” field, enter a number within the recommended range of 0 to 10.

Via the SX Tool

The **Filter Time Constant** is entered at Item **FTCn** (dec. addresses 94, 102, 110, 118, 126, 134, 142 and 150).

AI: Offset Value

An offset value, in the units of the analog input, is used to compensate for analog transmitters which do not have a true zero output, or for wiring resistance to RTD sensors. The offset value is added to the analog value calculated from the range parameters.

Via the GX Tool

Select XTnAIn and Data. At the “Offset Value” field, enter a number in the units of the analog input.

Via the SX Tool

The **offset value** is defined in Items **OFSn** (n=1-8, at dec. addresses 95, 103, 111, 119, 127, 135, 143, 151). Enter a value in the units of the analog input.

AI Notes

1. When the XT-9100 is connected to the DX controller, you can view the AI value and alarm limits from the DX front panel. See *Display Panel and Keypads* in the *DX-9100 Technical Bulletin*.
2. Analog input values can be read via the SX Tool at Item AIn (dec.12 to dec.19). (Only AI1-AI6 are used.)
3. Analog input alarm status can be seen via the SX Tool at Item AIS (dec.11), Bit X1, X3...X15 for high alarm condition and X2, X4...X16 for low alarm condition.
4. Configure all AIs as Active or Passive, whether they are used or not. A configured AI is shown by an inner border around its function box on the screen of the GX Tool.

Binary (Digital) Input Configuration

An XT-9100 can accept up to 16 digital inputs, depending on the hardware configuration. The first eight digital inputs are connected to XP1, and the next eight digital inputs to XP2.

Each digital input is defined and configured by the following parameters:

- User name and description (GX Tool only)
- Input type
- Counter prescaler

Inputs may be defined as maintained or pulse type. With maintained type contacts the extension module status follows the status of the contact. With pulse type contacts the extension module sets and resets the status at each pulse of the input contact.

DI User Name and Description (GX Tool Only)

Via the GX Tool

Select XTnDIn, then Data. Enter as appropriate:

User Name (maximum 8 characters)

Description (maximum 24 characters)

DI: Input Type

Via the GX Tool

Select XTnDIn, then Data. At the "Digital Input Type" field, enter 0 for maintained contact or 1 for pulse contact.

Via the SX Tool

The **input type** for the 2 x 8 possible inputs can be configured in Item DIT1 for XP1 (dec.64) and in Item DIT2 (dec.65) for XP2, bits X1-X8 for D11-DI8, as follows:

0 = Maintained Contact

1 = Pulse Contact

DI: Counter Prescaler

The digital input transitions of XP1 are counted as follows:

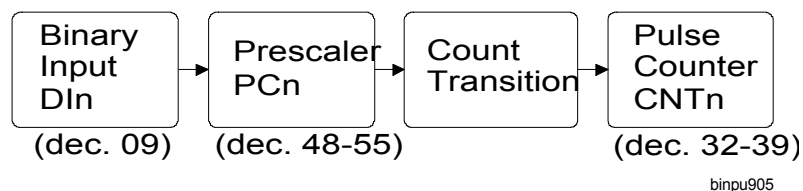

A count transition occurs when the number of positive transitions of the digital input (DIn) equals the value of the prescaler (PCn). The pulse counter (CNTn) (n = 1-8) counts the count transitions.

Note: Counters are only available in the XP1 location.

Via the GX Tool

Select XTnDIn, then Data. At the "Prescaler (counts)" field, enter from 1 to 255.

Via the SX Tool

Enter the **prescaler** at Item PCn (dec. 48-55) within the range 1-255.

DI Notes

1. When the XT-9100 is connected to the DX controller you can view the DI status and counter values from the DX front panel. See *Display Panel and Keypads* in the *DX-9100 Technical Bulletin*.
2. The status of the digital inputs can be seen at Item DIS1 (dec.09), bits X1-X8, and Item DIS2 (dec.10), bits X1-X8.

Analog Output Configuration

Each analog output is defined and configured by the following parameters:

- User name and description (GX Tool only)
- Output type

The following parameters are defined in the DX controller for the analog output:

- Source
- Range

AO User Name and Description (GX Tool Only)

Via the GX Tool

Select XTnAOn and then Data. Enter as appropriate:

User Name (maximum 8 characters)

Description (maximum 24 characters)

AO: Output Type

Via the GX Tool

Select XTnAOn and Data, then enter at the "Type of Output" field:

- 0 = disabled
- 1 = 0-10 VDC
- 2 = 0-20 mA
- 3 = 4-20 mA

Via the SX Tool

The **output type** is configured in Item AOT (dec. 87) in bit pairs X2-X1, X4-X3, up to X16-X15 for outputs 1-8, respectively. To define the output signal type, set the bits as follows (for Output #1):

X2 X1 = 00	Output Disabled
X2 X1 = 01	Output 0-10 V
X2 X1 = 10	Output 0-20 mA
X2 X1 = 11	Output 4-20 mA

The other outputs are set in a similar way.

AO: Source

The source of the analog output signal is defined in the DX controller.

Via the GX Tool

Select XTnAO_n, Data and the "Source Point" field. Enter * and select the required source variable.

Via the SX Tool

Refer to Extension Module Configuration in the DX-9100 Configuration Guide.

AO: Range

The AO range of the analog output is defined in the DX controller. The High Range defines the level of control source signal that corresponds to an output of 100%.

The Low Range defines the level of control source signal that corresponds to an output of 0%.

When the source point is equal to the high range, then the output will be at the maximum signal (10 V/ 20 mA). When the source point is equal to low range, then the output will be at the minimum signal (0 V, 0/4 mA).

Via the GX Tool

Select XTnAO_n and Data, then enter the desired values in the "High Range" and "Low Range" fields.

Via the SX Tool

Refer to *Extension Module Configuration* in the *DX-9100 Configuration Guide*.

AO Notes

1. When the XT-9100 is connected to the DX controller you can view and override the AO value from the DX front panel. See *Display Panel and Keypads* in the *DX-9100 Technical Bulletin*.
2. The analog output values can be read in percent at Item AO1-8 (dec.20-27) with the SX Tool. (only AO7 and AO8 are used.)

**Binary (Digital)
Output
Configuration**

Each digital output is defined and configured by the following parameters:

- User name and description (GX Tool only)
- Output type
- Pulse time
- Status on Communication Failure

The following parameter is defined in the DX controller for the digital output:

- Source

**DO User Name
and Description
(GX Tool Only)*****Via the GX Tool***

Select XTnDOn and then Data. Enter as appropriate:

User Name (maximum 8 characters)

Description (maximum 24 characters)

DO: Output Type***Via the GX Tool***

Select XTnDOn, then select On/Off or Pulse. For the Pulse type, the output switches for a configurable pulse time for each state transition of the command output.

Via the SX Tool

The **output type** can be set in Item DOT1 (dec. 66) for XP1 and Item DOT2 (dec. 67) for XP2 as follows (n = 1-8):

Xn = 0 On/Off Type

Xn = 1 Pulse Type

DO: Pulse Time

This parameter is set once for all pulse type outputs in the XT-9100.

Via the GX Tool

Select XTn and Data, then enter a value in the “Digital Output Pulse Time” field. The valid range is 1 to 255 (5 msec to 1.275 sec pulse time).

Via the SX Tool

The **digital output pulse time** is used by modules configured with pulse type outputs, to determine the output pulse width. It is defined in Item DOPT (dec. 68) in units of 5 msec. The default value is 200, which represents a pulse time of 1 sec.

Note: All connected DO points must be configured to ensure correct operation with the DX controller. When a single XP-9106/7 (4DO) relay module is connected, select 8DO on the GX Tool and define outputs DO1-DO4 only.

DO: Status on Comm. Failure

Via the GX Tool

First configure an XT module. Select PM, XTn, and an analog or digital configuration. Then select the just configured XTn and Data.

To set this flag, at the "Status on comm. fail" (communication failure) field, enter 0 or 1.

When this field is set to "0," the digital outputs are switched off upon a XT Bus failure, and the corresponding Item values are reset to zero.

When set to "1," the digital outputs hold their current state upon a XT Bus failure.

Via the SX Tool

The **Output Hold/Reset on Communication Failure** flag is set at Bit X2 of Item XTS (dec.69).

X2 = 0 Output reset upon communication failure.

X2 = 1 Output hold upon communication failure.

DO: Source

The source of the digital output signal is defined in the DX controller.

Via the GX Tool

Select XTnDOn, Data and then the "Source Point" field. Enter * and select the required source variable.

Via the SX Tool

Refer to *Extension Module Configuration* in the *DX-9100 Configuration Guide*.

DO Notes

1. When the XT-9100 is connected to the DX controller you can view and override the DO value from the DX front panel. See *Display Panel and Keypads* in the *DX-9100 Technical Bulletin*.
2. The digital output status can be seen at Item DOS1 (dec.07) for XP1 and Item DOS2 (dec.08) for XP2, bits X1-X8 for outputs DO 1-8 with the SX Tool.
3. A configured DO is shown by an inner border around its function box.

Configure all DOs as On/Off or Pulse, whether they are used or not. The only exception is for the 4-output relay module XP-9106/7. When only one module is installed, select 8DO, but only configure DO1-DO4. When two modules are installed, configure both as one 8DO module, and configure DO1-DO8.

Specifications and Technical Data

The specifications and technical data for all available modules are listed in this section. The following environment specifications apply to all modules:

Operating Environment	0 to +50 °C / +32 to +122 °F 10 to 90% RH, noncondensing
Storage Environment	-20 to +70 °C / -4 to +158 °F
Housing Material	ABS - polycarbonate, self-extinguishing VO UL 94
Housing Protection	IP20 (IEC529)
Agency Compliance	All modules: CE Directive 89/336/EEC EN 50081-1, EN 50082-1 XP-9106 and TR-9100: CE Directive 73/23/EEC EN 60730 All modules except XP-9106 and TR-9100: UL Listed, CSA Certified

XT-9100-8304

Electrical Requirements	24 VAC +10% - 15%, 50/60 Hz
Power Consumption	6 VA
Fuse	315 mA slow blow
Terminations:	
Power Supply	1 x 1.5 mm ² / 16 AWG (maximum) cable
Serial Interface	RS-485 cable
XP-BUS	Connector cable provided with XP
Serial Interface	RS-485; 9600 baud; opto-isolated
LED Indicators	Power On (Flashing = no communication.) Receive Data Transmit Data
Weight	225 gr. / 7.9 oz.

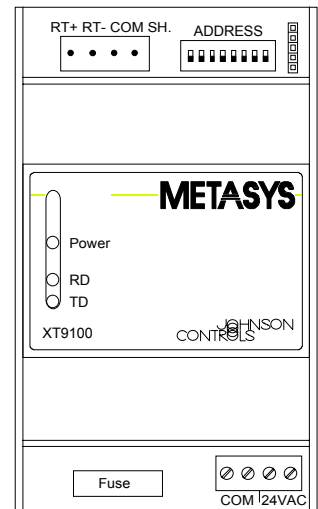

TR-9100-8001*

Electrical Requirements	230 VAC +/-10%, 50/60 Hz
Electrical Output	24 VAC, 50/60 Hz
Power Capacity	Up to 12 VA
230 V Fuse (F1)	200 mA slow blow (internal)
24 V Fuse (F2)	800 mA slow blow
Terminations	1 x 1.5 mm ² / 16 AWG (maximum) cable
Weight	470 gr. / 16.6 oz.

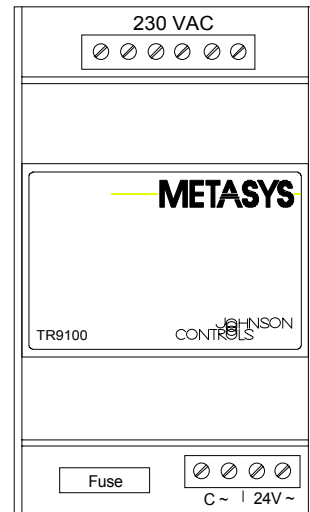

*The TR-9100 Transformer Module is not available in North America.

XP-9102-8304

Electrical Requirements	24 VAC +10% - 15%, 50/60 Hz
Power Consumption	4 VA
Terminations:	
Inputs/Outputs	1 x 1.5 mm ² / 16 AWG (maximum) cable
Power Supply	1 x 1.5 mm ² / 16 AWG (maximum) cable
XP-BUS	Connector cable provided
Analog Inputs	6 inputs, 10-bit resolution Inputs jumper selectable: <ul style="list-style-type: none"> ● 0 to 10 VDC, > 300 Kohm impedance ● 0/4 to 20 mA, 100 ohm impedance ● RTD (Ni1000 (JCI type), Pt1000, A99)
Analog Outputs	2 outputs, jumper selectable: <ul style="list-style-type: none"> ● 0 to 10 VDC, (10 mA) ● 0/4 to 20 mA, max. 500 ohm
LED Indicators	Each output level indicated by two LEDs, one for 0% and one for 100%. The LEDs are equally bright at 50% output.
Active Sensor Supply	15 VDC, 30 mA
Weight	260 gr. / 9.2 oz.

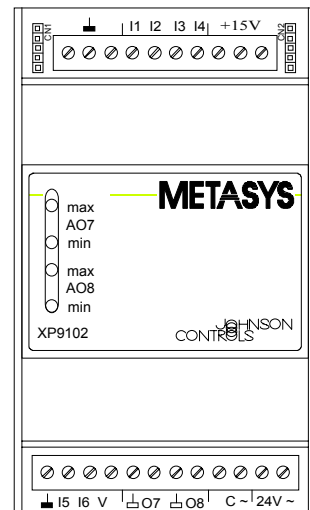

XP-9103-8304

Electrical Requirements

Powered from XT-9100

Terminations:

Outputs

1 x 1.5 mm² / 16 AWG (maximum) cable
Connector cable provided

XP-BUS

Digital Outputs

8 triac outputs, 500 mA RMS,
On/Off or Pulse Type

LED Indicators

Each output indicated by an LED

Weight

120 gr. / 4.2 oz.

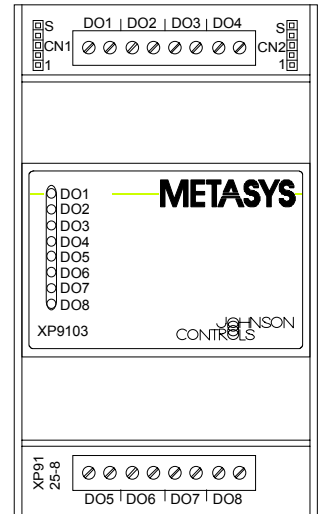

XP-9104-8304

Electrical Requirements

24 VAC +10% - 15%, 50/60 Hz

Power Consumption

1.5 VA

Terminations:

Inputs/Outputs

1 x 1.5 mm² / 16 AWG (maximum) cable

Power Supply

1 x 1.5 mm² / 16 AWG (maximum) cable

XP-BUS

Connector cable provided

Digital Input

4 digital inputs from potential-free
contacts, Maintained or Pulse Type

Digital Outputs

4 triac outputs, 500 mA RMS,
On/Off or Pulse Type

LED Indicators

Each input/output indicated by an LED

Weight

120 gr. / 4.2 oz.

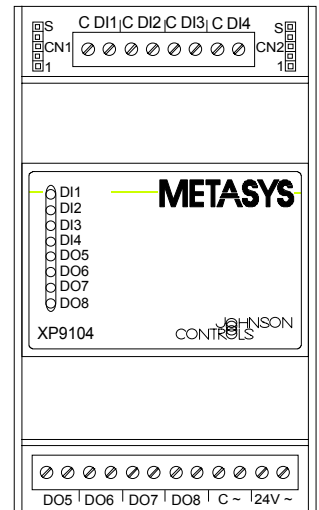

XP-9105-8304

Electrical Requirements	24 VAC +10% - 15%, 50/60 Hz
Power Consumption	2.5 VA
Terminations:	
Inputs	1 x 1.5 mm ² / 16 AWG (maximum) cable
Power Supply	1 x 1.5 mm ² / 16 AWG (maximum) cable
XP-BUS	Connector cable provided
Digital Input	8 digital inputs from potential-free contacts, Maintained or Pulse Type Transition counter function; min. 20 ms ON, 20 ms OFF
LED Indicators	Each input indicated by an LED
Weight	140 gr. / 4.9 oz.

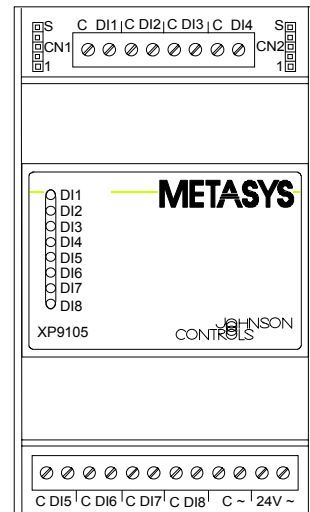

XP-9106-8304

Electrical Requirements	24 VAC +10% - 15%, 50/60 Hz
Power Consumption	7 VA
Terminations:	
Outputs	1 x 1.5 mm ² / 16 AWG (maximum) cable
Power Supply	1 x 1.5 mm ² / 16 AWG (maximum) cable
XP-BUS	Connector cable provided
Digital Outputs	4 relay outputs, SPDT relay 250 VAC / 5 Amp., On/Off or Pulse Type
LED Indicators	Each output indicated by an LED
Weight	175 gr. / 6.1 oz.

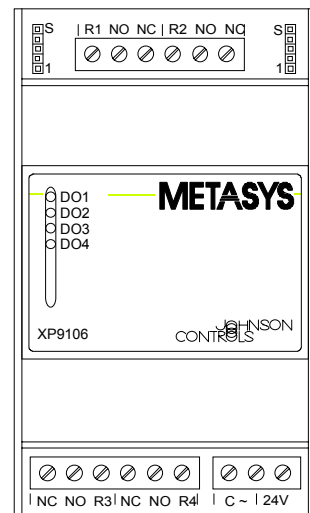

Note: A replacement module label with the output LEDs marked DO5, DO6, DO7, DO8 is packed with each module, for use when two XP-9106 modules are installed next to each other to provide eight relay outputs.

XP-9107-8304

Electrical Requirements	24 VAC +10% - 15%, 50/60 Hz
Power Consumption	7 VA
Terminations:	
Outputs	1 x 1.5 mm ² / 16 AWG (maximum) cable
Power Supply	1 x 1.5 mm ² / 16 AWG (maximum) cable
XP-BUS	Connector cable provided
Digital Outputs	4 relay outputs, SPDT relay 30 VAC / 5 Amp., On/Off or Pulse Type
LED Indicators	Each output indicated by an LED
Weight	175 gr. / 6.1 oz.

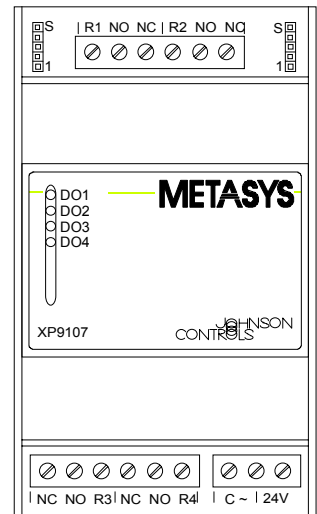

Note: A replacement module label with the output LEDs marked DO5, DO6, DO7, DO8 is packed with each module, for use when two XP-9107 modules are installed next to each other to provide eight relay outputs.

Commissioning and Troubleshooting

XP-9102 Jumper Settings

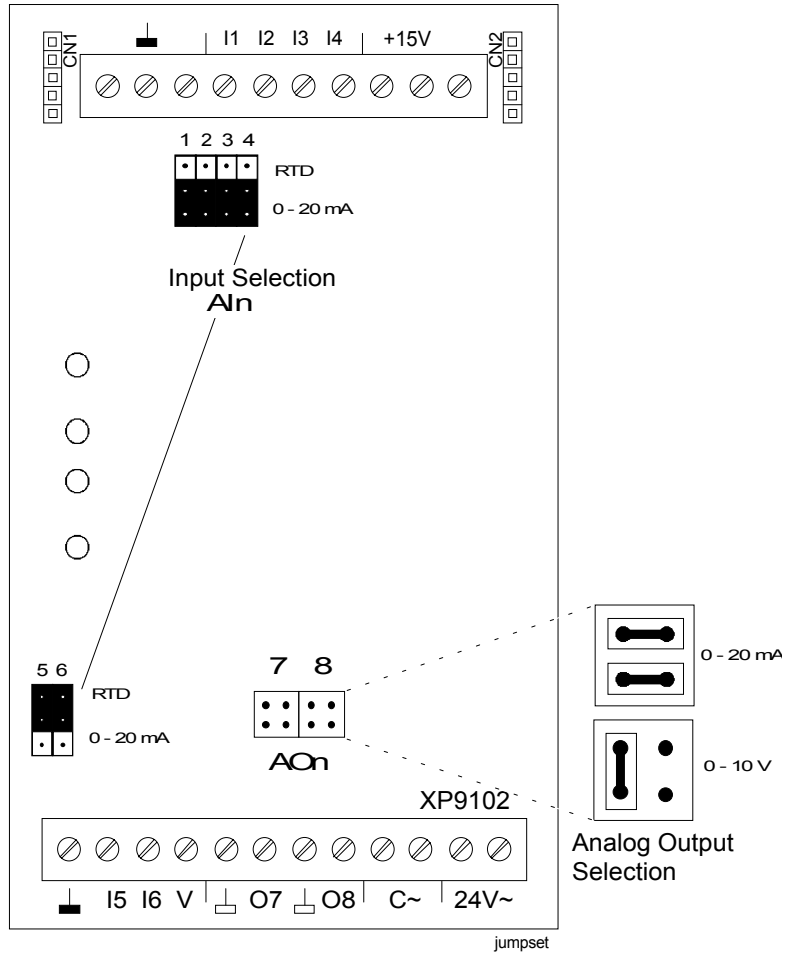

Figure 17: Jumper Details For the XP-9102

All jumper selections must be made *before* installing the module and *before* power is applied to the module.

Remove the cover of the module and select the **Analog Input Type** using *one* jumper per input in the respective position RTD or 0 to 20 mA inputs. Remove the jumper completely to select 0 to 10 V.



CAUTION: A maximum of 30 mA is available from the 15 V supply of the module.

Select **Analog Output Type** using the jumpers as shown above. Two jumpers are required for 0 to 20 mA and one jumper for 0 to 10 V output.

XT-9100 Switch Settings

Select **Module Address** (for the Supervisory System) on the address switches in 8-bit binary format. An address of 0 is not permitted on the XT-Bus.

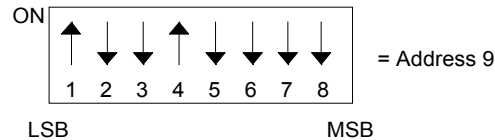

Power Up

After inspecting the field wiring, switch and jumper settings, and the XT-Bus cabling, power may be applied to the XT-9100 and XP-910x modules. If the software configuration has not yet been downloaded to the XT-9100 (stored in non-volatile EEPROM), take the necessary steps using the GX-9100 Graphic Configuration Software (GX Tool).

At power up, the XT-9100 performs a configuration check, comparing the software defined configuration with the number and types of expansion modules actually connected to the XT-9100. If the configurations do not match, a configuration error will be indicated by the power LED of the XT-9100 (see *LEDs* below). The LED indicators on the front of the XT-9100 module can be used to determine that the XT-9100 is functioning properly.

Note: Remove power from the XT/XP modules before making any wiring changes, including the disconnection of existing XP modules or the connection of new XP modules. The XT-9100 module requires a power interruption after every hardware change to perform a configuration check. Failure to remove power may result in a configuration error.

LEDs

There are three LEDs on the front of the XT-9100 module: Power (*Power*), Receive Data (*RD*), and Transmit Data (*TD*).

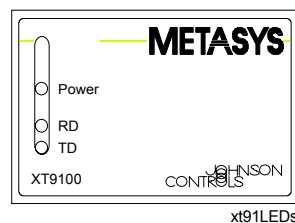

Figure 18: LEDs on the Front of the XT-9100

When power is applied to the XT-9100, the power LED will indicate the following conditions:

- The power LED will light up continuously if the XT-9100 has established good communications with the DX controller over the serial link (XT-Bus) and there are no configuration errors in the XT.
- The power LED will flash at a frequency of about once per second if there is no communication with the DX controller.
- The power LED will flash at a frequency of about twice per second if communications with the the DX controller are good but there is a configuration error in the XT, no communication with the XPs, or an incorrect XP has been connected.

The Receive Data LED lights to indicate that data is on the XT-Bus/N2 Bus. The Transmit Data LED lights to indicate that the XT-9100 is responding on the XT-Bus/N2 Bus.

If there is a communications fault, you should check the XT-Bus/N2 Bus cabling, and also make sure that the address setting on the XT-9100 agrees with the XT-9100 address configured in the DX controller or supervisory system.

If there is a configuration error, you should make sure that the software configuration being downloaded to the XT-9100 agrees with the actual types and number of expansion modules connected to the XT-9100. Any error in the configuration will also be indicated in Items OPMO (dec. 01) and I2CE (dec. 02). (See *Appendix A—Item Table* for details). Another possible cause of this error could be an improperly seated ribbon cable connecting the expansion module communications bus.

Supply Protection

The XT-9100 has a 315 mA slow blow fuse to protect the 24 VAC supply. If the fuse blows, replace it with a new fuse with the correct rating. If the fuse blows again, replace the module.

All other modules are equipped with a protective device to limit the current drawn from the 24 VAC supply to approximately 500 mA in the event of an internal failure or an external short circuit due to incorrect wiring to the binary input terminals which have the same “common” as the 24 VAC supply. If a module is not working (no LEDs show when the input or output is active), check the wiring. If the wiring is correct, replace the module.

Via the GX Tool

Download via the DX Controller and the N2 Bus

Connect an RS-232C/RS-485 converter (type MM-CVT101-x in North America and type IU-9100-810x in Europe) to one of the serial communication ports (COM1 or COM2) of the personal computer on which the GX Tool is running. Connect the N2 Bus of the DX controller to the converter unit connected to the PC.

Set the address switches and jumpers on the DX controller and XT/XP devices as required, and connect the XT/XP devices to the XT Bus of the DX controller. (See the corresponding sections of this bulletin and the *DX-9100 Technical Bulletin* for details.)

If the DX controller and XT/XP devices are installed and wired, verify all field wiring and sensor voltage/current signals. It is recommended that controlled devices be isolated during download and initial startup.

Note: Do not download an untested configuration into an installed device. Test the configuration on a simulator panel before downloading.

Apply 24 VAC power to the DX controller and XT/XP devices.

On the GX Tool select Action, Download, and DX. Enter the DX controller address (0-255) in the Address field and the PC serial communication port (COM1 or COM2). Click on OK.

Checks are made before the data is downloaded to the controller, and a message is displayed on the screen if a value is outside the normal range for that parameter. The user may abort the download process and change the value in the configuration or click on OK to ignore the message and download the entered value.

When the download is complete, select Action, Download, and XT/XTM. Verify that the correct port is selected, and click on OK.

For subsequent downloads, where the XT addresses have not been changed, the loading can be done in one process by selecting Action, Download, and DX and XT/XTM.

Download via the DX Controller (RS-232-C Port)

Connect the serial communication port of the PC directly to the RS-232-C port of the DX controller. See the *DX-9100 Technical Bulletin* for details. Proceed as for *Download via DX controller and N2 Bus*.

Upload via the DX Controller

Only complete DX/XT configurations should be uploaded from the DX controller. Save the current configuration on the PC screen and select File, New, then Action, Upload, and DX and XT/XTM. Enter the DX controller address (0-255) and PC port (COM1 or COM2). Click on OK.

Download via the N2 Bus

Set the address switches and jumpers on the XT/XP devices as required. Connect the XT/XP devices to the N2 Bus and the N2 Bus to the converter on the PC.

If the XT/XP devices are installed and wired, verify all field wiring and sensor voltage/current signals. It is recommended that controlled devices be isolated during download and initial startup. Apply 24 VAC power to the XT/XP devices.

Up to eight XT-9100s may be downloaded at one time from the GX Tool over the N2 Bus.

If the XT/XP devices are not used with a DX controller, it is recommended that one configuration file is created for each XT-9100 in Module XT1.

Select Action, Download, XT/XTM. Enter the PC serial communication port (COM1 or COM2), and click on OK.

Upload via the N2 Bus

Only one XT-9100 may be uploaded at one time and the configuration will be stored under XT1. Select Action, Upload, XT/XTM. Enter the XT-9100 address (1-255) in the Address field and the PC serial communication port (COM1 or COM2). Click on OK.

Via the SX Tool

The SX Tool communicates with the XT-9100 only via a DX controller and XT-9100 configuration data can only be changed item by item with the SX Tool. It is not possible to download or upload a complete configuration.

Appendix A—Item Table

Items

Each constant, variable or parameter in an XT-9100 Extension Module can be addressed via an Item code. All Items are listed in the *Item Table* which follows.

Note: It is important to note that EEPROM Items can only be written approximately 10,000 times, so that write commands from cyclical processes in supervisory systems must be avoided. The DX controller does not write to EEPROM items except during a configuration download.

Item Types

The format of any XT-9100 Item is described by the following types:

- Float:** Floating point number (2 bytes).
- 1 Byte:** Unsigned integer number from 0 to 255.
- 8 Bits:** 8 bits (1-byte) used to store logic states.
- 2 Bytes:** Unsigned integer number from 0 to 65,535.
- 16 Bits:** 16 bits (2-byte) used to store logic states.
- 4 Bytes:** Unsigned integer number from 0 to 4,294,967,295.

Floating Point Numbers

An XT-9100 floating point number consists of two bytes which are bit-encoded using the following format:

15	14	13	12	11	10	9	8	7	6	5	4	3	2	1	0
E3	E2	E1	E0	S	M10	M9	M8	M7	M6	M5	M4	M3	M2	M1	M0

- where:
- E3 - E0 = 4-bit exponent
 - S = sign bit (1 = negative)
 - M10 - M0 = 11-bit mantissa

- A number is normalized when the most significant bit of the mantissa is set (M10 = 1).
- A number is zero when all bits of the mantissa are 0.
- The value of a number is:

$$\langle \text{NUMBER} \rangle = \langle \text{SIGN} \rangle * .\langle \text{MANTISSA} \rangle * 2^{\text{exp} \langle \text{EXPONENT} \rangle}$$

Examples:

$$\begin{aligned} 1 &= 1400\text{H} \quad \text{or} \quad \text{B001H} \\ -1 &= 1\text{C00H} \quad \text{or} \quad \text{B801H} \\ 100 &= 7640\text{H} \quad \text{or} \quad \text{B064H} \end{aligned}$$

Item TableAbbreviations used in the *Item Table*:**ADDRESS****Dec.** Decimal Item Address**Hex.** Hexadecimal Item Address**TYPE** Item Type as described previously under **Item Type**.**R/W** Read/Write conditions:**R** Read only Item**R/W** Read/Write Item**R/W (E)** Read/Write Item (in EEPROM)**CNF** Configuration Item (in EEPROM)**TAG** Name for Item or bit position within an Item. Note that in bit-addressed Items, not all bits have an explicit Tag.

ADDRESS		TYPE	R/W	TAG	DESCRIPTION
Dec.	Hex.				
00	00	1 Byte	R	MODL	Device Model: 08 hex. for XT-9100
01	01	8 Bits	R/W	OPMO	Operation Mode (status)
		X8 X7 X6 X5 X4 X3 X2 X1			
		X1 = 1			Watchdog test
		X2 = 1			DO Error
		X3 = 1			DI Error
		X4 = 1			AI Error
		X5 = 1			AO Error
		X6			Not used (set to 0)
		X7	R	FAIL	XT Fail Mode (= XTS, Bit X2)
		X8 = 1		PWR	Power Fail or Comm. Failure
02	02	8 Bits	R	I2CE	Bus Error
		X8 X7 X6 X5 X4 X3 X2 X1			
		X1 = 1			XP1: DO Error
		X2 = 1			XP2: DO Error
		X3 = 1			XP1: DI Error
		X4 = 1			XP2: DI Error
		X5 = 1			XP1: AI or Counter 1-4 Error
		X6 = 1			XP1: AO or Counter 5-8 Error
		X7 = 1			EEPROM Error
		X8 = 1		HARD	XPx Hardware not available
03	03	1 Byte			Not used

ADDRESS		TYPE	R/W	TAG	DESCRIPTION
Dec.	Hex.				
04	04				Not used
to					
06	06				Not used
07	07	8 Bits	R/W	DOS1	Binary Output Status XP1 (A/B)
		X8 X7 X6 X5 X4 X3 X2 X1			
		Xn = 1	(n = 1-4)	DOn	XP1A: Output #n is On
		Xn = 1	(n = 5-8)	DOn	XP1B: Output #n is On
08	08	8 Bits	R/W	DOS2	Binary Output Status XP2 (A/B)
		X8 X7 X6 X5 X4 X3 X2 X1			
		Xn = 1	(n = 1-4)	DOn	XP2A: Output #n is On
		Xn = 1	(n = 5-8)	DOn	XP2B: Output #n is On
09	09	8 Bits	R	DIS1	Binary Input Status XP1
		X8 X7 X6 X5 X4 X3 X2 X1			
		Xn = 1	(n = 1-8)	DIn	XP1: Binary Input #n is On
10	0A	8 Bits	R	DIS2	Binary Input Status XP2
		X8 X7 X6 X5 X4 X3 X2 X1			
		Xn = 1	(n = 1-8)	DIn	XP2: Binary Input #n is On
11	0B	16 Bits	R	AIS	Analog Input Status
		X16 X15 X14 X13 X12 X11 X10 X9 X8 X7 X6 X5 X4 X3 X2 X1			
		X1 = 1		AIH1	High Alarm Condition
		X2 = 1		AIL1	Low Alarm Condition
		X3 = 1		AIH2	High Alarm Condition
		X4 = 1		AIL2	Low Alarm Condition
		X5 = 1		AIH3	High Alarm Condition
		X6 = 1		AIL3	Low Alarm Condition
		X7 = 1		AIH4	High Alarm Condition
		X8 = 1		AIL4	Low Alarm Condition
		X9 = 1		AIH5	High Alarm Condition
		X10 = 1		AIL5	Low Alarm Condition
		X11 = 1		AIH6	High Alarm Condition
		X12 = 1		AIL6	Low Alarm Condition
		X13 = 1		AIH7	High Alarm Condition
		X14 = 1		AIL7	Low Alarm Condition
		X15 = 1		AIH8	High Alarm Condition
		X16 = 1		AIL8	Low Alarm Condition

ADDRESS		TYPE	R/W	TAG	DESCRIPTION
Dec.	Hex.				
12	0C	Float	R	AI1	Analog Input Value #1
13	0D	Float	R	AI2	Analog Input Value #2
14	0E	Float	R	AI3	Analog Input Value #3
15	0F	Float	R	AI4	Analog Input Value #4
16	10	Float	R	AI5	Analog Input Value #5
17	11	Float	R	AI6	Analog Input Value #6
18	12	Float	R	AI7	Analog Input Value #7
19	13	Float	R	AI8	Analog Input Value #8
20	14	Float	R/W	AO1	Analog Output Value #1
21	15	Float	R/W	AO2	Analog Output Value #2
22	16	Float	R/W	AO3	Analog Output Value #3
23	17	Float	R/W	AO4	Analog Output Value #4
24	18	Float	R/W	AO5	Analog Output Value #5
25	19	Float	R/W	AO6	Analog Output Value #6
26	1A	Float	R/W	AO7	Analog Output Value #7
27	1B	Float	R/W	AO8	Analog Output Value #8
28	1C				Not used
to					
31	1F				Not used
32	20	4 Bytes	R/W	CNT1	DI1 Pulse Count - XP1
33	21	4 Bytes	R/W	CNT2	DI2 Pulse Count - XP1
34	22	4 Bytes	R/W	CNT3	DI3 Pulse Count - XP1
35	23	4 Bytes	R/W	CNT4	DI4 Pulse Count - XP1
36	24	4 Bytes	R/W	CNT5	DI5 Pulse Count - XP1
37	25	4 Bytes	R/W	CNT6	DI6 Pulse Count - XP1
38	26	4 Bytes	R/W	CNT7	DI7 Pulse Count - XP1
39	27	4 Bytes	R/W	CNT8	DI8 Pulse Count - XP1
40	28				Not used
to					
47	2F				Not used
48	30	1 Byte Int	CNF	PC1	Prescaler DI1 Counter (default = 1)
49	31	1 Byte Int	CNF	PC2	Prescaler DI2 Counter (default = 1)
50	32	1 Byte Int	CNF	PC3	Prescaler DI3 Counter (default = 1)
51	33	1 Byte Int	CNF	PC4	Prescaler DI4 Counter (default = 1)
52	34	1 Byte Int	CNF	PC5	Prescaler DI5 Counter (default = 1)
53	35	1 Byte Int	CNF	PC6	Prescaler DI6 Counter (default = 1)
54	36	1 Byte Int	CNF	PC7	Prescaler DI7 Counter (default = 1)
55	37	1 Byte Int	CNF	PC8	Prescaler DI8 Counter (default = 1)

ADDRESS		TYPE	R/W	TAG	DESCRIPTION
Dec.	Hex.				
56	38	1 Byte	CNF	DIL1	Internal use only
57	39	1 Byte	CNF	DIL5	Internal use only
58	3A	1 Byte	CNF	DIL9	Internal use only
59	3B	1 Byte	CNF	DILD	Internal use only
60	3C	1 Byte	CNF	DOL1	Internal use only
61	3D	1 Byte	CNF	DOL5	Internal use only
62	3E	1 Byte	CNF	DOL9	Internal use only
63	3F	1 Byte	CNF	DOLD	Internal use only
64	40	8 Bits X8 X7 X6 X5 X4 X3 X2 X1 Xn = 0 (n = 1-8) Xn = 1	CNF	DIT1	Binary Input Type XP1 (A/B) XP1: DI n = Maintained Contact (default) XP1: DI n = Pulse Contact
65	41	8 Bits X8 X7 X6 X5 X4 X3 X2 X1 Xn = 0 (n = 1-8) Xn = 1	CNF	DIT2	Binary Input Type XP2 (A/B) XP2: DI n = Maintained Contact (default) XP2: DI n = Pulse Contact
66	42	8 Bits X8 X7 X6 X5 X4 X3 X2 X1 Xn = 0 (n = 1-8) Xn = 1	CNF	DOT1	Binary Output Type XP1 (A/B) XP1: DO n = ON/OFF Type (default) XP1 : DO n = Pulse Type
67	43	8 Bits X8 X7 X6 X5 X4 X3 X2 X1 Xn = 0 (n = 1-8) Xn = 1	CNF	DOT2	Binary Output Type XP2 (A/B) XP2: DO n = ON/OFF Type (default) XP2: DO n = Pulse Type
68	44	1 Byte	CNF	DOPT	Binary Output Pulse Time (* 5 ms.) (default value of 200 = 1 s)
69	45	8 Bits 0 0 0 0 0 X2 X1 X1 = 0 X1 = 1 X2 = 0 X2 = 1 X8 X7 X6 X5 X4 X3	CNF	XTS	XT-9100 Type Settings 50 Hz Power Line (default) 60 Hz Power Line Output Reset on communication failure (default) Output Hold on communication failure Not used
70	46				Not used
to					
74	4A				Not used

ADDRESS		TYPE	R/W	TAG	DESCRIPTION
Dec.	Hex.				
75	4B	1 Byte	CNF	AI2C	Internal use only
76	4C	1 Byte	CNF	AMOD	Internal use only
77	4D	8 Bits	CNF	IOMAP	Extension Module I/O Map
		X8 X7 X6 X5 X4 X3 X2 X1			
		X1 = 0			XP1A : I/O1 & I/O2 Not Used
		X1 = 1			XP1A : I/O1 & I/O2 Used
		X2 = 0			XP1A : I/O3 & I/O4 Not Used
		X2 = 1			XP1A : I/O3 & I/O4 Used
		X3 = 0			XP1B : I/O5 & I/O6 Not Used
		X3 = 1			XP1B : I/O5 & I/O6 Used
		X4 = 0			XP1B : I/O7 & I/O8 Not Used
		X4 = 1			XP1B : I/O7 & I/O8 Used
		X5 = 0			XP2A : I/O1 & I/O2 Not Used
		X5 = 1			XP2A : I/O1 & I/O2 Used
		X6 = 0			XP2A : I/O3 & I/O4 Not Used
		X6 = 1			XP2A : I/O3 & I/O4 Used
		X7 = 0			XP2B : I/O5 & I/O6 Not Used
		X7 = 1			XP2B : I/O5 & I/O6 Used
		X8 = 0			XP2B : I/O7 & I/O8 Not Used
		X8 = 1			XP2B : I/O7 & I/O8 Used
78	4E	8 Bits	CNF	IOTYP	Extension Module I/O Type
		0 0 0 0 X4 X3 X2 X1			
		X1 = 0			XP1A : I/O1 & I/O2 Digital
		X1 = 1			XP1A : I/O1 & I/O2 Analog
		X2 = 0			XP1A : I/O3 & I/O4 Digital
		X2 = 1			XP1A : I/O3 & I/O4 Analog
		X3 = 0			XP1B : I/O5 & I/O6 Digital
		X3 = 1			XP1B : I/O5 & I/O6 Analog
		X4 = 0			XP1B : I/O7 & I/O8 Digital
		X4 = 1			XP1B : I/O7 & I/O8 Analog
		X8...X5			Not Used

ADDRESS		TYPE	R/W	TAG	DESCRIPTION
Dec.	Hex.				
79	4F	8 Bits	CNF	IOMOD	Extension Module I/O Mode
		X8 X7 X6 X5 X4 X3 X2 X1			
		X1 = 0			XP1A : I/O1 & I/O2 Input
		X1 = 1			XP1A : I/O1 & I/O2 Output
		X2 = 0			XP1A : I/O3 & I/O4 Input
		X2 = 1			XP1A : I/O3 & I/O4 Output
		X3 = 0			XP1B : I/O5 & I/O6 Input
		X3 = 1			XP1B : I/O5 & I/O6 Output
		X4 = 0			XP1B : I/O7 & I/O8 Input
		X4 = 1			XP1B : I/O7 & I/O8 Output
		X5 = 0			XP2A : I/O1 & I/O2 Input
		X5 = 1			XP2A : I/O1 & I/O2 Output
		X6 = 0			XP2A : I/O3 & I/O4 Input
		X6 = 1			XP2A : I/O3 & I/O4 Output
		X7 = 0			XP2B : I/O5 & I/O6 Input
		X7 = 1			XP2B : I/O5 & I/O6 Output
		X8 = 0			XP2B : I/O7 & I/O8 Input
		X8 = 1			XP2B : I/O7 & I/O8 Output
80	50				Not used
to					
85	55				Not used
86	56	2 Bytes	CNF	MTBC	Maximum Time Between Communications (default = 60 seconds)
87	57	16 Bits	CNF	AOT	Analog Output Type
		X16 X15 X14 X13 X12 X11 X10 X9			X8 X7 X6 X5 X4 X3 X2 X1
		X2 X1			Signal Analog Output #1
		= 00			Output Disabled
		= 01			Output 0 to 10 V
		= 10			Output 0 to 20 mA
		= 11			Output 4 to 20 mA
		X4 X3			Signal Analog Output #2 (as X2 X1)
		X6 X5			Signal Analog Output #3 (as X2 X1)
		X8 X7			Signal Analog Output #4 (as X2 X1)
		X10 X9			Signal Analog Output #5 (as X2 X1)
		X12 X11			Signal Analog Output #6 (as X2 X1)
		X14 X13			Signal Analog Output #7 (as X2 X1)
		X16 X15			Signal Analog Output #8 (as X2 X1)

ADDRESS		TYPE	R/W	TAG	DESCRIPTION
Dec.	Hex.				
88	58	16 Bits	CNF	AIT1	Input Type of Analog Input #1
		0 0 0 0 X12 X11 X10 X9 X4 X3 X2 X1		X8 X7 X6 X5 X4 X3 X2 X1	Measurement Units
			= 0000		Linear (active sensor)
			= 0001		Degrees Celsius (RTD)
			= 0010		Degrees Fahrenheit (RTD)
			= 0011		Per Cent
		X5 = 1			Enable Square Root of Input
		X6 = 1			Alarm on Unfiltered Value
		X7 = 0			0-10 Volts (default)
		X7 = 1			0-2 Volts, 0-20 mA or RTD
		X8 = 1			20 % Suppression
		X12 X11 X10 X9			Linearization and Sensor Type
			= 0000		Linear (active sensor)
			= 0001		Nickel 1000 Sensor (JCI)
			= 0010		Nickel 1000 Extended Range (JCI)
			= 0011		A99 Sensor (JCI)
			= 0100		PT1000 Sensor (DIN)
89	59	Float	CNF	HR1	High Range Analog Input #1 (default = 100)
90	5A	Float	CNF	LR1	Low Range Analog Input #1 (default = 0)
91	5B	Float	R/W (E)	HIA1	High Alarm Limit Analog Input #1 (default =100)
92	5C	Float	R/W (E)	LOA1	Low Alarm Limit Analog Input #1 (default = 0)
93	5D	Float	R/W (E)	ADF1	Differential on Alarm Limit (default = 1)
94	5E	Float	CNF	FTC1	Filter Constant Analog Input #1 (default = 0)
95	5F	Float	CNF	OFS1	Offset Analog Input #1 (default = 0)
96	60	16 Bits	CNF	AIT2	Input Type of Analog Input #2 (bits as AIT1)
97	61	Float	CNF	HR2	High Range Analog Input #2 (default = 100)
98	62	Float	CNF	LR2	Low Range Analog Input #2 (default = 0)
99	63	Float	R/W (E)	HIA2	High Alarm Limit Analog Input #2 (default =100)
100	64	Float	R/W (E)	LOA2	Low Alarm Limit Analog Input #2 (default = 0)
101	65	Float	R/W (E)	ADF2	Differential on Alarm Limit (default = 1)
102	66	Float	CNF	FTC2	Filter Constant Analog Input #2
103	67	Float	CNF	OFS2	Offset Analog Input #2 (default = 0)
104	68	16 Bits	CNF	AIT3	Input Type of Analog Input #3 (bits as AIT1)
105	69	Float	CNF	HR3	High Range Analog Input #3 (default = 100)
106	6A	Float	CNF	LR3	Low Range Analog Input #3 (default = 0)
107	6B	Float	R/W (E)	HIA3	High Alarm Limit Analog Input #3 (default =100)
108	6C	Float	R/W (E)	LOA3	Low Alarm Limit Analog Input #3 (default = 0)
109	6D	Float	R/W (E)	ADF3	Differential on Alarm Limit (default = 1)
110	6E	Float	CNF	FTC3	Filter Constant Analog Input #3
111	6F	Float	CNF	OFS3	Offset Analog Input #3 (default = 0)

ADDRESS		TYPE	R/W	TAG	DESCRIPTION
Dec.	Hex.				
112	70	16 Bits	CNF	AIT4	Input Type of Analog Input #4 (bits as AIT1)
113	71	Float	CNF	HR4	High Range Analog Input #4 (default = 100)
114	72	Float	CNF	LR4	Low Range Analog Input #4 (default = 0)
115	73	Float	R/W (E)	HIA4	High Alarm Limit Analog Input #4 (default =100)
116	74	Float	R/W (E)	LOA4	Low Alarm Limit Analog Input #4 (default = 0)
117	75	Float	R/W (E)	ADF4	Differential on Alarm Limit (default = 1)
118	76	Float	CNF	FTC4	Filter Constant Analog Input #4
119	77	Float	CNF	OFS4	Offset Analog Input #4 (default = 0)
120	78	16 Bits	CNF	AIT5	Input Type of Analog Input #5 (bits as AIT1)
121	79	Float	CNF	HR5	High Range Analog Input #5 (default = 100)
122	7A	Float	CNF	LR5	Low Range Analog Input #5 (default = 0)
123	7B	Float	R/W (E)	HIA5	High Alarm Limit Analog Input #5 (default =100)
124	7C	Float	R/W (E)	LOA5	Low Alarm Limit Analog Input #5 (default = 0)
125	7D	Float	R/W (E)	ADF5	Differential on Alarm Limit (default = 1)
126	7E	Float	CNF	FTC5	Filter Constant Analog Input #5
127	7F	Float	CNF	OFS5	Offset Analog Input #5 (default = 0)
128	80	16 Bits	CNF	AIT6	Input Type of Analog Input #6 (bits as AIT1)
129	81	Float	CNF	HR6	High Range Analog Input #6 (default = 100)
130	82	Float	CNF	LR6	Low Range Analog Input #6 (default = 0)
131	83	Float	R/W (E)	HIA6	High Alarm Limit Analog Input #6 (default =100)
132	84	Float	R/W (E)	LOA6	Low Alarm Limit Analog Input #6 (default = 0)
133	85	Float	R/W (E)	ADF6	Differential on Alarm Limit (default = 1)
134	86	Float	CNF	FTC6	Filter Constant Analog Input #6
135	87	Float	CNF	OFS6	Offset Analog Input #6 (default = 0)
136	88	16 Bits	CNF	AIT7	Input Type of Analog Input #7 (bits as AIT1)
137	89	Float	CNF	HR7	High Range Analog Input #7 (default = 100)
138	8A	Float	CNF	LR7	Low Range Analog Input #7 (default = 0)
139	8B	Float	R/W (E)	HIA7	High Alarm Limit Analog Input #7 (default =100)
140	8C	Float	R/W (E)	LOA7	Low Alarm Limit Analog Input #7 (default = 0)
141	8D	Float	R/W (E)	ADF7	Differential on Alarm Limit (default = 1)
142	8E	Float	CNF	FTC7	Filter Constant Analog Input #7
143	8F	Float	CNF	OFS7	Offset Analog Input #7 (default = 0)
144	90	16 Bits	CNF	AIT8	Input Type of Analog Input #8 (bits as AIT1)
145	91	Float	CNF	HR8	High Range Analog Input #8 (default = 100)
146	92	Float	CNF	LR8	Low Range Analog Input #8 (default = 0)
147	93	Float	R/W (E)	HIA8	High Alarm Limit Analog Input #8 (default =100)
148	94	Float	R/W (E)	LOA8	Low Alarm Limit Analog Input #8 (default = 0)
149	95	Float	R/W (E)	ADF8	Differential on Alarm Limit (default = 1)
150	96	Float	CNF	FTC8	Filter Constant Analog Input #8
151	97	Float	CNF	OFS8	Offset Analog Input #8 (default = 0)



Johnson Controls, Inc.
Westendhof 3
45143 Essen
Germany

www.johnsoncontrols.com
System 91 Manual
XT-9100 Technical Bulletin
Rev. Level 0702