



# techsystem

automatyka klimatyzacja wentylacja

▸ zapoznaj się z naszą ofertą

# FX03

## Configurable Terminal Unit Controller

The FX03 is a Configurable Terminal Unit Controller in the Facility Explorer range of products.

The controller is designed specifically to provide direct digital control of terminal unit applications with heating and/or cooling coils, an electric heater and a three-speed or variable speed fan.

These applications include close control units, fan coil units, unit ventilators and chilling or heating ceiling beam installations. The device can be configured by the installer, without the need of a PC and software tool, using a set of on-board dip-switches.

The controller is designed for field installation in a panel or enclosure or for mounting by original equipment manufacturers (OEMs) on DIN-rail or directly on a surface.

The space comfort set point, occupancy mode and fan speed may be adjusted from a wide range of room sensor modules with options for a digital display.

Communication options are available to enable the controller to be integrated into an N2 Open or BACnet® network of a building automation system.

The BACnet interface of the controller complies with the ANSI/ASHRAE Standard 135-2004 for sharing data other devices on the network.



FX03  
Terminal Unit Controller

- **Field Selectable application type, communication protocol and room module, via dip-switches on controller**

Ease of configuration, installation and commissioning - no special tool required.

- **230 VAC power supply**

- **5 VDC / 15 VDC / 24 VAC power supply for Field Devices, directly provided by the controller**

Low installed cost for a wide range of terminal unit applications

- **Modular range of Room Sensor Modules**

Suitable for a wide range of installations with wall-mount, flush-mount and hand-held remote control options.

- **Network Communications Options - N2 Open and BACnet MS/TP**

Provides cost effective means to connect the controller to a supervisory system.

- **BACnet MS/TP with Peer to Peer Communication**

Provides cost effective solution for small networks and environmental control of rooms featuring more controllers to be driven by a single Room Sensors Module.

- **Configurable using FX Tools**

Suitable for a wide range of applications for environmental control using the commissioning features of the FX CommPro N2 or BACnet software package.

## Easy Configuration and Installation

The FX03 has a factory programmed application but communication and configuration options (Room Sensor Module Type, Outputs Management, for example) are field selectable via onboard dip-switches, not requiring computer or any additional software.

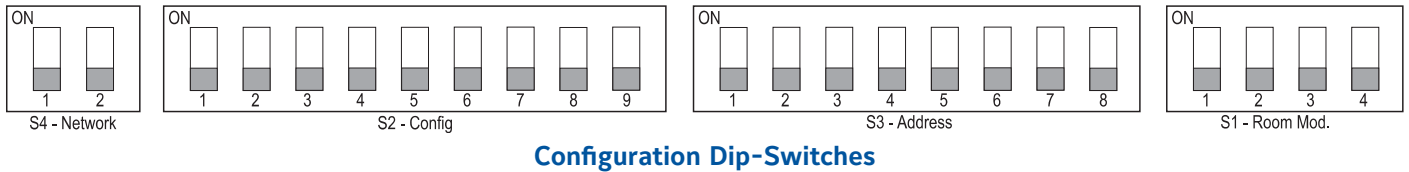

An advanced configuration level for complex operations (such as Peer-to-Peer communication) and the fine tuning of parameters can be achieved via commissioning feature of the FX CommPro N2 or BACnet software package.

## Onboard Inputs and Outputs (I/Os)

The hardware inputs and outputs have been selected to cover the main requirements for wide cost efficient terminal unit controls.

The heating and cooling outputs, depending on the configuration settings, connect to the most common valve actuator types in the market, from low cost On-Off and thermally driven valve actuators to the effective 0-10 VDC modulating valve actuators.

Relays are provided for direct control of the fan, On-Off valve actuators and/or an electric heater if installed.

Inputs are provided for temperature set point, fan speed override, occupancy sensor or button and shutoff from a window contact or condensation sensor. Digital Inputs polarity (N.O.; N.C.) is configurable via network.

A series of optional inputs are provided for return air temperature, heating/cooling changeover, coil and discharge air temperature sensors.

The space temperature sensor may be mounted in the fan coil unit return air or in the room sensor module.

### Digital Inputs

<b>DI1</b>	Off / Window open
<b>DI2</b>	Condensing Sensor
<b>DI3</b>	Occupancy Sensor
<b>DI4</b>	General Purpose, Network Integration
<b>OCC</b>	RSM Temporary Occupied Push Button

### Analog Inputs

<b>T1</b>	Room / Return Air Sensor
<b>T2</b>	Change-over Sensor / Contact
<b>T3</b>	Soft-Start Sensor
<b>T4</b>	Discharge Air Sensor
<b>FAN</b>	RSM Fan Speed Override Input
<b>SP</b>	RSM Set-Point Input
<b>S</b>	RSM Room Air Sensor (NTC 10K)

### Digital Outputs

<b>Clg</b>	On/Off Cooling Output (230 VAC Relay)
<b>Htg</b>	On/Off Heating Output (230 VAC, 16 A Relay)
<b>Fan1</b>	Fan Speed 1
<b>Fan2</b>	Fan Speed 2
<b>Fan3</b>	Fan Speed 3
<b>TAc</b>	DAT Cooling Thermal Actuator Output
<b>TAh</b>	DAT Heating Thermal Actuator Output
<b>LED</b>	RSM LED Output

### Analog Outputs

<b>Y</b>	0-10 VDC Proportional Cooling Output
<b>W</b>	0-10 VDC Proportional Heating Output
<b>VSF</b>	0-10 VDC Variable Fan Speed

## Room Sensor Modules

A unique and specific series of room sensor modules (RSM) is available for use with the FX03 controllers. The RSM series features both infra-red communicating modules and non-communicating (parallel wired connections) room sensor modules.

### Communicating Infra-Red (IR) Modules

- Wall Mount with integral IR receiver;
- Horizontal Flush Mount with integral IR receiver;
- Vertical Flush Mount with integral IR receiver;
- IR Receiver with integral sensor and hand-held remote control.

The fully featured and stylish Infra-Red communicating RSM are well suited to light commercial, residential or apartment applications. They feature an internal temperature sensor, onboard IR receiver and buttons allowing the occupant to adjust the temperature setpoint value or request a warmer or cooler setpoint, to override the speed of a three-speed fan or to manage the terminal unit operating modes in case a supervisor network is not available.



**LP-RSM003-000C**



**LP-RSM003-001C**



**LP-RSM003-003C  
and LP-RSM003-004C**

### Communicating Infra-Red (IR) Room Sensor Modules

### Non-Communicating Modules (parallel wired)

- Wall Mount without display
- Wall Mount with display

The non-communicating (parallel wired) RSM are designed for commercial and light industrial applications and are available with and without LCD display with an internal temperature sensor and an optional dial allowing the occupant to adjust the temperature setpoint value or request a warmer or cooler setpoint.

The LCD display and the dial on the front of the module allow the room occupant to view and adjust the space temperature. Modules with LCD display will automatically request the temporary occupied (bypass) mode when the dial is moved during unoccupied periods. On models without LCD display this function is activated by means of the temporary occupied button on the left side of the module.

Certain models also have a dial or button to enable the occupant to override the speed of a three-speed fan.



**TM Series**



**RS Series**

### Non-communicating (Parallel Wired) Room Sensor Modules

## Auxiliary Sensor (T1÷T4)

The FX03 Controller provides a set of auxiliary, fixed purpose, analog input T1÷T4 (NTC50KW).

Each analog input features an associated function which is automatically enabled when the sensor presence is detected on the controller terminals at power up.

### Remote Control Temperature

The FX03 controller offers the option to control a remotely sensed temperature, different from the one being provided by connected Room Sensor Module.

This result shall be achieved in the following ways, depending on the connected RSM series.

#### TM Series

Connect the remote NTC10KOhm Sensor to S-Com Terminals.

#### RS Series

Option not available. There is no possibility to show the effective controlled temperature on the RS display.

#### RSM Series

Connect the remote NTC50kOhm Sensor to T1-Com Terminals. The LP-RSM003-000C and LP-RSM003-001C models offer the possibility to configure their display to show either the local temperature reading or the remote reading through the FX03 Controller (T1).

## Automatic or Manual Changeover (2 pipes)

The FX03 controller offers the possibility to select the effective HVAC (Heating/Cooling) Mode in both automatic or manual mode. In case the changeover sensor (T2) is connected, the controller automatically selects the functioning mode in relation to the supplied water temperature as following:

T2 < 20°C, Effective HVAC Mode = COOLING

T2 > 30°C, Effective HVAC Mode = HEATING

20°C ≤ T2 ≤ 30°C, Dead Band

If the controller doesn't detect the changeover temperature sensor (T2) connected, it switches to manual changeover logic. In this particular case the HVAC mode can be selected through a dry contact connected to 'T2' and 'COM' terminals and selected the functioning mode as following:

T2-COM = Open Contact, Effective HVAC Mode = COOLING

T2-COM = Closed Contact, Effective HVAC Mode = HEATING

Communicating (IR) Room Sensor Modules offers the possibility to set the Effective HVAC Mode directly from their user interface, thru the 'Mode' button.

The controller HVAC Mode can be overridden at any time thru the supervisory network which takes the highest priority over the local selections.

### Soft Start

The FX03 controller offers, in case the internal coil sensor (T3) is connected, the possibility to enable the soft-start strategy for enhanced occupant comfort.

This strategy, based on the internal coil sensor (T3), defines the intervention point of the fan depending on the internal coil temperature avoiding to blow non or partially conditioned air.

The soft-start strategy works as following:

#### Heating

T3 > 38°C, Fan enabled

T3 < 34°C, Fan disabled

#### Cooling

T3 < 18°C, Fan Enabled

T3 > 20°C, Fan Disabled

## Discharge Air Limit (COOL only)

The FX03 controller offers, in case the discharge air sensor (T4) is connected, the possibility to enable the blown air temperature limit strategy for an enhanced occupant comfort.

This strategy, based on the discharge air sensor (T4) and active in cooling operations only, limits the temperature of the chilled blown air by proportionally closing the cooling valve in case the discharge air temperature falls under a pre-defined comfort discharge air limit setpoint.

The Fan operations are not affected by this strategy.

## On-board Power Supply for Field Devices

In order to achieve a lower installation cost, the FX03 controller has been designed to provide on its terminals the power supplies for the most common field devices in use on terminal unit applications, including:

**Room Sensor Modules** 5 VDC ±10%, 10mA;

15 VDC ±5%, 30mA;

**Occupancy Sensors** 15 VDC ±5%, 20mA;

**Valve Actuators** 24 VAC ±10%, 50/60 Hz, 7 VA

## Occupancy Comfort with Economy

The fan coil unit controller offers three modes of operation – occupied (comfort), bypass (temporarily occupied) and unoccupied (night and weekends).

These occupancy modes can be set from an operator workstation or network controller on a Metasys network, from another device on the network or controlled by the room occupants from a local room sensor module.

Set point adjustment can be limited within a certain range to allow occupants control over their environment, but not to compromise energy savings.

This option gives maximum flexibility to the local occupant and allows maximum energy savings when there is no supervisory system installed.

A “window open” sensor may be connected to the controller to switch it to the “Energy Hold-off” mode to avoid energy waste. The controller may also be set to “off” by the supervisory network or room sensor modules when the space is not in use.

Where there are multiple fan coil units in a room, the controllers may be configured on the BACnet network to operate in parallel to control the temperature in the space in unison.

For applications where the cooling coil or pipes are located in the ceiling, a condensation sensor may be connected to switch off cooling if water is condensing on the pipes.

## Fan Coil Unit Types

The controller may be configured to control fan coil units with a single water coil (2 pipe) or with separate heating and cooling coils (4 pipe).

Two pipe fan coil units may be controlled as heating or cooling only, or may be configured to change control from heating to cooling depending on an external change-over signal.

When an electric heater is installed, the heater may be configured as the heat source in a two pipe fan coil unit with a chilled water supply or as supplemental heat in a 2 pipe fan coil unit with a hot water supply or a 4 pipe fan coil unit in heating mode.

## Fan Control Options

The controller may be configured to control a single-speed, two-speed or three-speed fan.

A variable fan speed proportional output, 0–10 VDC, is also available as option.

Options are also available to keep the fan running continuously at low speed or to allow the fan to cycle on and off as the space temperature reaches the given setpoint.

The fan speed override command is only active when the space is occupied and when there is no “Energy Hold-off” in order to save energy consumption.

The fan control can be activated only once the heating or cooling element has been activated avoiding to blow not conditioned air.

If the fan is forced to off, the electric heater control is de-activated and the fan continues to run at low speed for a short time to prevent over-heating in the fan coil unit.

In normal cooling or electrical heating control operations the fan will be switched off only after a delay to prevent over-heating or condensation in the fan coil unit.

## Communication Options

The FX03 Terminal Unit Controller provides N2 Open and BACnet MS/TP communication options that are field selectable via dip-switch for connection to a supervisory network, including the Metasys M3i Workstation and the NAE Network Automation Engine that integrates the controller into a facility-wide building management network.

## Automatic Binding

The FX03 controller with BACnet Communication, features an automatic binding function.

This option, when selected, activates a pre-defined Peer-to-Peer communication network allowing to share information points between controllers.

This feature enables to have a BACnet "client" device connected to the RSM, sharing the RSM information points (Details as following) with up to (5) five expected BACnet "server" devices:

- Space Temperature;
- Temperature Setpoint;
- Occupancy Mode;
- HVAC Mode;
- Fan Speed.

Whenever a "server" device detects a valid space temperature sensor connected to its terminals (T1 or S), its value takes the priority over the value being passed by the "client" device through the Peer-To-Peer communication.

Temperature Setpoint, Occupancy Mode, HVAC Mode and Fan Speed will in any case being provided by the "client" device.

The automatic binding network structure is pre-defined in the source controller and strictly depends on the "client" MAC address. In case any of the "server" devices is missing on the network it will not affect the communication between the others and the information of the missing device will be reported through the network.

A set of Binary Input objects it is also available for alarms reporting purposes, including the expected "server" devices to be effectively present and communicating on the network.

As per BACnet ANSI / ASHRAE Standard 135-2004 the "client" device MAC address has to be set within the range 1 to 127 while "server" devices will have MAC address equal or greater than 128.

The pre-configured Peer-to-Peer automatic binding network structure is defined as following shown.

### Automatic Binding Network Structure

MAC Address	Reserved	Client	Server_1	Server_2	Server_3	Server_4	Server_5
		1	128	129	130	131	132
2	133	134	135	136	137		
3	138	139	140	141	142		
4	143	144	145	146	147		
5	148	149	150	151	152		
6	153	154	155	156	157		
7	158	159	160	161	162		
8	163	164	165	166	167		
9	168	169	170	171	172		
10	173	174	175	176	177		
11	178	179	180	181	182		
12	183	184	185	186	187		
13	188	189	190	191	192		
14	193	194	195	196	197		
15	198	199	200	201	202		
16	203	204	205	206	207		
17	208	209	210	211	212		
18	213	214	215	216	217		
19	218	219	220	221	222		
20	223	224	225	226	227		
21	228	229	230	231	232		
22	233	234	235	236	237		
23	238	239	240	241	242		
24	243	244	245	246	247		
25	248	249	250	251	252		

# Dimensions

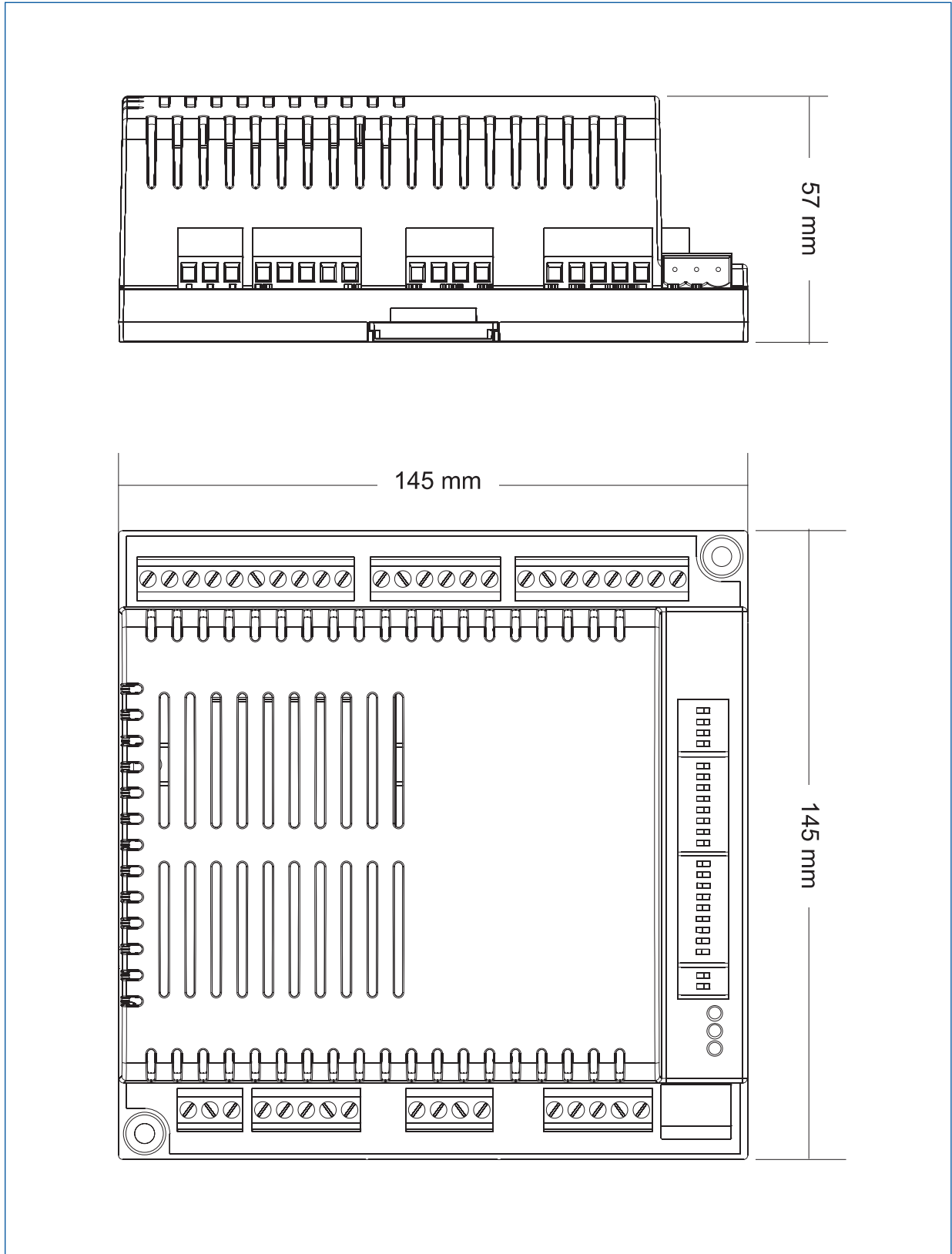

# Wiring Diagrams

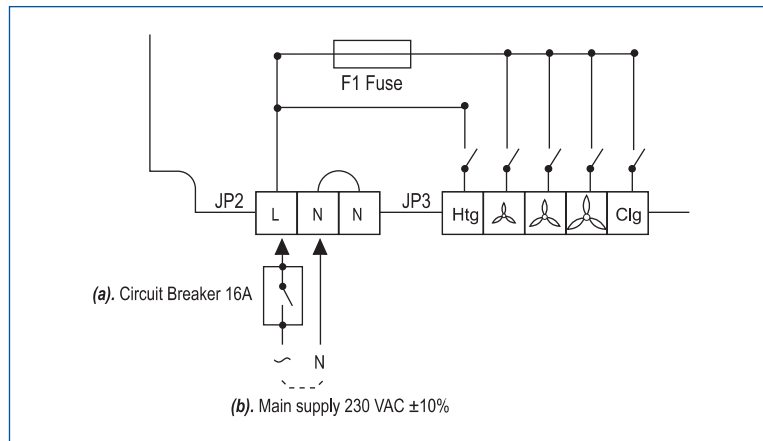

**FX03 230 VAC Power Supply**

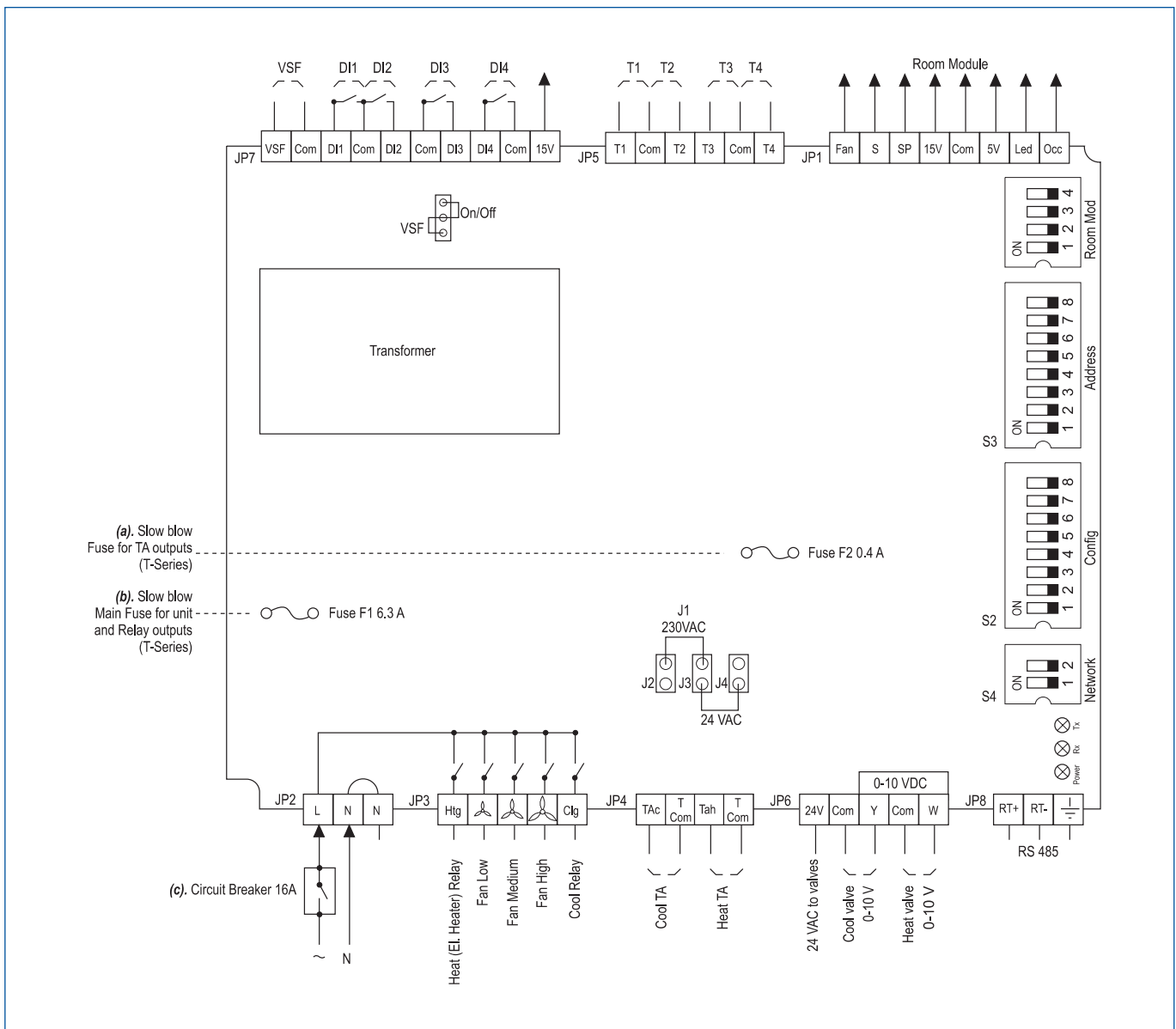

**FX03 Wiring Diagram**

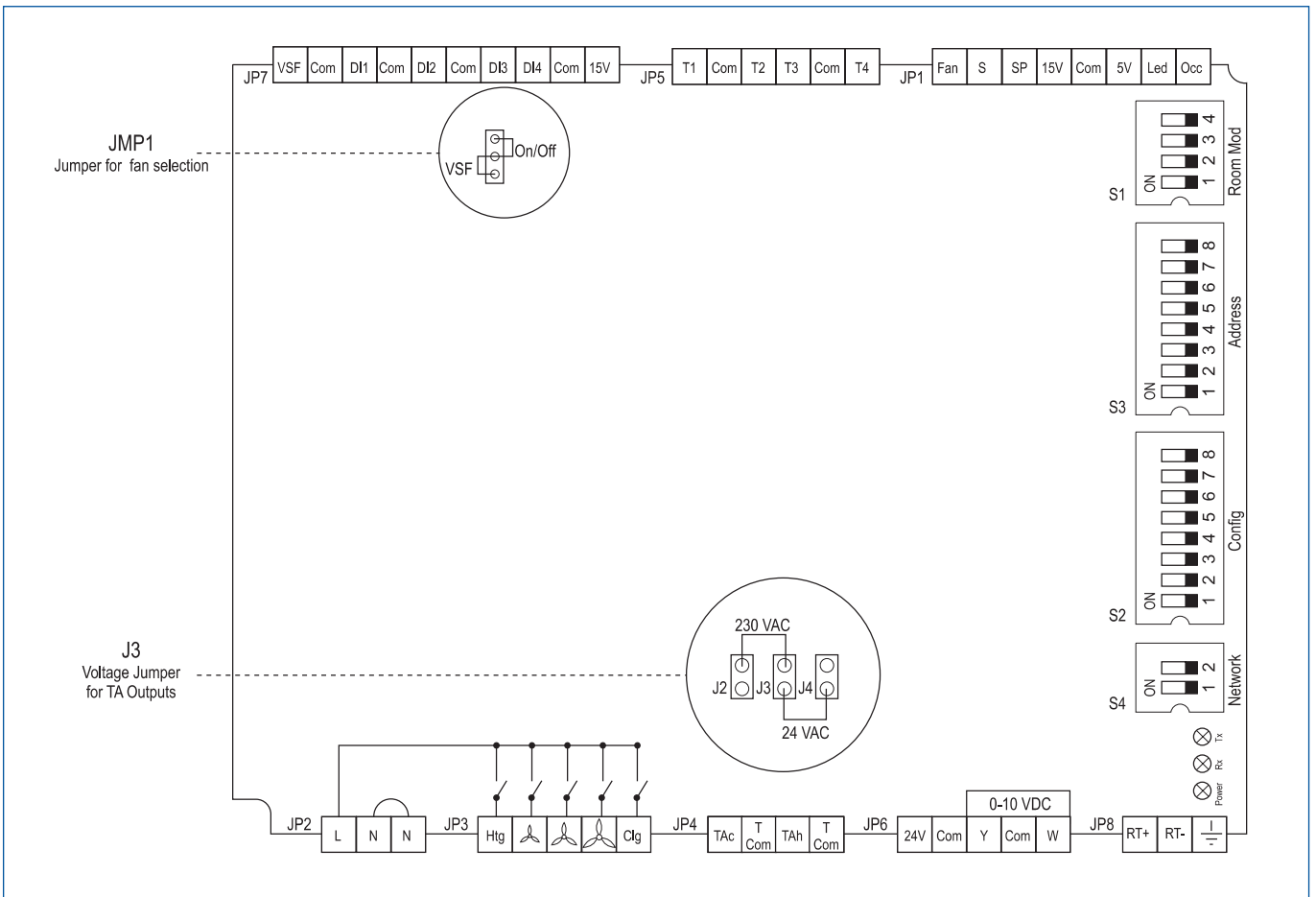



**FX03 Jumper Configuration**

## Ordering Codes

Codes	Description
LP-FX03A01-000C	230 VAC N2 / BACnet Terminal Unit Controller, No Cover
LP-FX03A11-000C	230 VAC N2 / BACnet Terminal Unit Controller
<b>Room Sensor Modules with LCD Display and Integrated IR Receiver</b>	
LP-RSM003-000C	Room Sensor Module, Wall Mount
LP-RSM003-001C	Room Sensor Module, Horizontal Flush Mount
LP-RSM003-003C	IR Receiver w/ Integrated Temperature Sensor
LP-RSM003-004C	IR Hand held remote control unit
<b>Room Sensor Modules without Display - 80 mm x 80 mm</b>	
TM-2140-0000	Room Sensor Module, temperature sensor only
TM-2150-0000	Room Sensor Module, occupancy button and LED
TM-2160-0000	Room Sensor Module, 12-28° C setpoint dial, occupancy button and LED
TM-2160-0002	Room Sensor Module, 12-28° C setpoint dial, occupancy button and LED, fan speed override
TM-2160-0005	Room Sensor Module, +/- setpoint dial, occupancy button and LED
TM-2160-0007	Room Sensor Module, +/- setpoint dial, occupancy button and LED, fan speed override
TM-2190-0000	Room Sensor Module, 12-28° C setpoint dial
TM-2190-0005	Room Sensor Module, +/- setpoint dial
<b>Room Sensor Modules with Backlit LCD Display - 80 mm x 80 mm</b>	
RS-1180-0000	Room Sensor Module, 12-28° C setpoint dial
RS-1180-0005	Room Sensor Module, +/- setpoint dial
RS-1180-0002	Room Sensor Module, 12-28° C setpoint dial, fan speed override
RS-1180-0007	Room Sensor Module, +/- setpoint dial, fan speed override
<b>Accessories</b>	
LP-KIT003-010C	Remote Temperature Sensor, NTC 50k $\Omega$ , Bulb, 80 cm leads
LP-KIT003-011C	Remote Temperature Sensor, NTC 50k $\Omega$ , Wall Mount, Decorative box
LP-KIT003-012C	Remote Temperature Sensor, NTC 50k $\Omega$ , Duct Mount
LP-KIT003-013C	Remote Temperature Sensor, NTC 50k $\Omega$ , Wall Mount, Decorative box
HX-9100-8001	Condensation (Dew Point) sensor
TE-9100-8502	Remote Temperature Sensor, NTC 10k $\Omega$ , Bulb, 150 cm leads
TS-9104-8700	Remote Temperature Sensor, NTC 10k $\Omega$ , Ceiling

## Technical Specification

<b>Products</b>	<b>LP-FX03xxx-xxx - FX03 Configurable Terminal Unit Controller</b>	
<b>Power Requirements</b>	<b>LP-FX03Axx-xxx</b> 230 VAC $\pm 10\%$ , 50/60 Hz, 12 VA (Including 24VAC (7VA) Power Supply for Actuators). Maximum current input 15A (Including I/Os).	
<b>External Fuse</b>	External fuse pr circuit breaker recommended	
<b>Ambient Operating Conditions</b>	0 to 50°C - 10 to 90% RH (non condensing)	
<b>Ambient Storage Conditions</b>	-20 to 70°C - 10 to 95% RH (non condensing)	
<b>Housing Protection</b>	<b>Plastic box</b> Material: ABS + polycarbonate , UL94-V0 flammability rating Finishing: TB Confirmed Lucid or Texture Colour: White GE80464 Protection Class: IP20 CEI/EN60529	
<b>Power Supply Output for Actuators</b>	24 VAC $\pm 15\%$ , 50/60 Hz, 7 VA	
<b>Power Supply Output for Room Sensor Modules</b>	5 VDC $\pm 10\%$ , 10mA 15 VDC $\pm 5\%$ , 30mA	
<b>Power Supply Output for Active Sensors</b>	15 VDC $\pm 5\%$ , 20mA	
<b>Mounting</b>	DIN Rail or 2 Screws	
<b>Dimensions (H x W x D)</b>	56 x 145 x 145 mm	
<b>Shipping Weight</b>	0.8 Kg	
<b>Terminations</b>	Screw Terminals. Max. 1 x 2.5 mm 2 (24 - 12 AWG) wires	
<b>Analog Inputs</b>	10-bit resolution - Not isolated	
	<b>Channel</b>	<b>Type</b>
	T1÷T4	NTC50K (50K @ 25°C) -10 ÷ 89° C $\pm 3\%$
	S	NTC10K (10K @ 25°C) 0 ÷ 40 °C $\pm 0,2$ °C
	Fan, SP	0 ÷ 10 VDC $\pm 0,05$ V (RS Series) 0 ÷ 5 VDC $\pm 0,05$ V (TM Series)
<b>Digital (Binary) Inputs</b>	Voltage Free Contacts	
<b>Digital (Binary) Outputs</b>	<b>Channel</b>	<b>Type</b>
	TAh, TAc	LP-FX03Axx-xxx (230 VAC): 230 VAC, 0,29A Max Triac (Fused, Max 0.4A) 24 VAC, 0,3A Max Triac (Fused, Max 0.4A)
	Clg,    (Fan speeds)	SPST 6(3)A 250VAC Relay (Fused, Max 6A)
	Htg	SPST 16A 250VAC Relay (Not Fused, Max 10A)
<b>Analog Outputs</b>	0 ÷ 10 VDC, 5 mA - Not Isolated $\pm 0,1$ VDC	
<b>BACnet® Communication</b>	B-ASC - BACnet® Application Specific Controller RS-485 (EIA-485)	
<b>Standard Compliance</b>	CE EMC Directive 89/336/EEC; IEC 60730-2-11; IEC 60730-1; EN 55014-1; EN 55014-2; IEC61000-3-3:1995, A1:2000; IEC61000-4-2; IEC61000-4-3; IEC61000-4-4; IEC61000-4-5; IEC61000-4-6; IEC61000-4-11;	

The performance specifications are nominal and conform to acceptable industry standards. For applications at conditions beyond these specifications, consult the local Johnson Controls office or representative. Johnson Controls shall not be liable for damages resulting from misapplication or misuse of its products.

All the marks herein are the marks of their respective owners.