



techsystem

automatyka klimatyzacja wentylacja

▸ zapoznaj się z naszą ofertą

TC-9100 Universal Controller

Introduction		Page 3
	• <i>Controller Hardware Models</i>	4
	• <i>Modes of Operation</i>	5
Software Configuration		9
	• <i>Analog Input Configuration (AI1 to AI4)</i>	10
	• <i>Digital Input Configuration (DI1 and DI2)</i>	13
	• <i>Output Module Configuration (OCN1 to OCN7)</i>	14
	• <i>Programmable Module Configuration (PM1 to PM6)</i>	24
	• <i>External Analog Input Configuration (XAI1 to XAI6)</i>	39
	• <i>Low Limit (Anti-freeze) Module Configuration</i>	40
	• <i>Summer/Winter Compensation Module</i>	41
	• <i>Auto-dial Feature</i>	42
	• <i>Supervisory Functions and Configuration</i>	43
	• <i>Configuration for a TM-9180 Room Command Module</i>	47
Installation		49
	• <i>Mounting</i>	49
	• <i>Wiring</i>	50
	• <i>Jumper and Switch Selections</i>	56
	• <i>Startup</i>	57
	• <i>Commissioning</i>	57
Specifications & Technical Data		59
	• <i>Ordering Codes</i>	60

Appendix 1: TC-9100 Item Descriptions and Tables	61
• <i>Table 1: Item List</i>	63
• <i>Table 2: Programmable Module Algorithms</i>	77
Appendix 2: Configuration Worksheets	85
• <i>Worksheet 1: Connections</i>	86
• <i>Worksheet 2: Configuration Parameters – Programmable Modules</i>	87
• <i>Worksheet 3: Configuration Parameters – Input/Output and General</i>	88

Introduction

The TC-9100 Universal microprocessor-based DDC Controller provides room temperature control and is designed for use with HVAC terminal units having a heating and/or cooling function, with and without fan-assisted air circulation or flow control by damper positioning. Applications include fan coil units, hot-water radiators and cold ceilings, variable air volume (VAV) units, and small air handling units.

The controller is fully configurable to provide a wide range of control strategies using its four analog inputs to measure temperatures and flow rates, its two digital inputs to detect environmental conditions such as space occupancy, window opening or fan failure, and its seven analog or binary outputs to control heating, cooling and air flow control devices. A **RS-1100** or **TM-9180** series room command module provides set point adjust capabilities and a temporary occupancy override of the COMFORT, STANDBY and NIGHT operating modes of the controller. The TM-9180 can also provide local time scheduling of the operating mode when the controller is not overridden by a supervisory system. The controller has a low limit temperature protection feature and automatic set point compensation for the winter and summer seasons.

When connected to a communications bus, the controller provides operating data to a supervisory system, which also allows a user to modify control set points and to set the operating mode of the controller either manually or according to a time schedule.

The TC-9100 controller is part of the System 91 series of controllers and is fully compatible with the Metasys network system. The compact size of the controller makes it easy to mount within the terminal unit housing, above a false ceiling or within a small control cabinet.



2667

Figure 1: TC-9100 Universal Controller



2335

Figure 2: RS-1160 Room Command Module



2333

Figure 3: TM-9180 Room Command Module

Note: The TM-9180 Room Command Module is only available as a replacement part from July 2006.

Controller Hardware Models

There are two models of the TC-9100 Universal Controller. Each model is available with fixed terminals or separable terminals.

Table 1: Controller Inputs and Outputs

Inputs/Outputs	Qty.	Type of Signal	Model
Analog Inputs	4	0 - 10 VDC	Models 1 and 2
Digital Input 1	1	Dry contact or HX-9100-8001 Condensation Sensor	
Digital Input 2	1	Dry contact	
Mode Contact (Occupancy Button)	1	Dry momentary contact	
LED Mode Signal	1	Voltage for LED in RS-1100 Series	
Analog Output 1a/b (Heating/Cooling)	2	0 - 10 VDC	Model 1 only
Analog Output 2	1	0 - 10 VDC	
Digital Outputs (PAT, DAT, 2-Stage On/Off, and On/Off)	5	Triac rated at 24 VAC (switched only - no power supplied)	Model 2 only
Digital Outputs (PAT, DAT, 2-Stage On/Off, and On/Off)	7	Triac rated at 24 VAC (switched only - no power supplied)	
Power Supply	1	24 VAC	Models 1 and 2

For detailed information about the physical characteristics of the inputs and outputs, refer to the *Specifications and Technical Data* section further in this document.

For detailed information about the configuration possibilities, refer to the appropriate *Software Configuration* section further in this document.

Note 1: Digital inputs 1 and 2 may be used with any sensor that provides a dry (voltage-free) and isolated contact, suitable for low-voltage (24 V) switching. Digital Input 1 may also be used with the Johnson Controls Condensation Sensor, code number HX-9100-8001. No other condensation sensor may be used except a sensor which provides a dry contact that is isolated from all other electrical circuits.

Note 2: The TC-9100 controller is compatible with the **RS-1100** series of room modules for room temperature, remote set point and temporary occupancy mode change inputs. The controller is also compatible with the TM-9180 Room Command Module, which also provides 3-speed fan override and operating mode override. **Only one RS-1150/RS1160 series module with an occupancy mode button or only one TM-9180 may be connected to the controller.**

Modes of Operation

The TC-9100 Universal Controller can operate in any of the following modes:

- Standalone mode
- Alternate mode
- Supervisory mode
- Low Limit (Anti-freeze) mode
- Summer/Winter Compensation mode
- Auto-dial mode

Standalone Mode

When the TC-9100 Universal Controller is *not* connected to a supervisory system via the communications bus, *nor* to a TM-9180 Room Command Module with LCD display, it will operate in one of three operating modes, which are indicated on the **RS-1150/RS-1160** Room Command Module, as follows:

- COMFORT (room occupied): LED on steady
- STANDBY (room unoccupied): LED flashing
- OFF (room not in use): LED off

The Operating mode is determined by the status of the digital inputs when configured as Window Contact or Occupancy Sensor, and may be modified by the occupancy button on the **RS-1100** series Room Command Module as shown in Table 2. When not assigned to a digital input, the Window Contact function is assumed to be Window Closed, and the Occupancy Sensor function is assumed to be Occupied.

Table 2: Standalone Modes

Input States:		Resulting Modes:	
Window Contact	Occupancy Sensor	Operating Mode	Alternate Mode (Occupancy Button)
Open	No Action	OFF	No Action
Closed	Occupied	COMFORT	STANDBY
	Unoccupied	STANDBY	COMFORT

Depending on the way that the controller is configured, the COMFORT, STANDBY, and OFF modes may change the Working Set Point (WSP) of any control module, and the OFF mode may be configured to override the output of each control module to close off the heating, cooling, or air flow devices.

For further details, refer to the subheading *Controller Algorithms 1-6 – General* under the *Programmable Module Configuration* section of this document.

Controller Digital Output Number 7 may be configured to switch on in COMFORT mode for auxiliary circuit control, such as individual room lighting. For further details, refer to the *Output Module Configuration* section of this document.

Alternate Mode

The Alternate mode is activated and reset by a momentary contact connected to the mode input terminals of the controller. This contact is provided by the occupancy button of the **RS-1150/RS-1160** Room Command Module.

The occupancy button on the TM-9180 Room Command Module can also provide this function via the room command module communication interface instead of the hard-wired contact.

When pressed for approximately one second, the occupancy button changes the operating mode of the controller to the Alternate mode, or back to the normal operating mode as shown in tables 2 and 3. The COMFORT (T) mode is active only for a period of one or two hours (dependent on the configuration: see the *Supervisory Mode Configuration* section), after which the controller automatically resets to the normal operating mode.

Note: Only one **RS-1100** module with an occupancy button or only one TM-9180 may be connected to the controller.

Supervisory and TM-9180 Modes

When connected to a supervisory system via the communications bus, or to a TM-9180 Room Command Module, the controller may operate in COMFORT, STANDBY or OFF operating modes, and additionally in NIGHT mode. These modes are indicated on the TM-9180 or **RS-1100** (if connected), as follows:

- COMFORT (room occupied): LED on steady,
- STANDBY (room unoccupied): LED flashing,

- NIGHT (scheduled or manually set unoccupied): LED off,
- OFF (room not in use): LED off.

The Operating modes are set by the supervisory system and are modified by the Window Contact and Occupancy Sensor inputs (if configured), and by the occupancy button on the room command module, as shown in Table 3. The Window Contact input always switches the controller to OFF mode, and a MANUAL mode command from the supervisory system overrides the action of the Occupancy Sensor and occupancy button.

Table 3: Supervisory Modes

Window Contact	Input States:		Resulting Modes:	
	Supervisory Mode	Occupancy Sensor	Operating Mode	Alternate Mode (Occupancy Button)
Open	Any Mode	No Action	OFF	No Action
Closed	OFF	Occupied	OFF	OFF
		Unoccupied	OFF	OFF
	NIGHT	Occupied	NIGHT	COMFORT (T)
		Unoccupied	NIGHT	COMFORT (T)
	STANDBY	Occupied	STANDBY	COMFORT
		Unoccupied	STANDBY	COMFORT (T)
	COMFORT	Occupied	COMFORT	STANDBY
		Unoccupied	STANDBY	COMFORT
	OFF/MANUAL	No Action	OFF	No Action
	NIGHT/MANUAL		NIGHT	
	STANDBY/MANUAL		STANDBY	
	COMFORT/MANUAL		COMFORT	

Depending on the way that the controller is configured, the COMFORT, STANDBY, NIGHT and OFF modes may change the Working Set Point (WSP) of any control module, and the OFF mode may be configured to override the output of each control module to close off the heating, cooling, or air flow devices.

For further details, refer to the subheading *Controller Algorithms 1-6 – General* under the *Programmable Module Configuration* section of this document.

Supervisory systems available from Johnson Controls include the NCM 311/361 in the Metasys Network System, the CS-9105 Control Station, and the Companion System.

Note: A supervisory system which is setting the operating mode of the controller will have priority over a locally connected TM-9180 Room Command Module.

**Low Limit
(Anti-freeze)
Mode**

The TC-9100 Universal Controller may be configured to set any of the analog outputs to the maximum level, or switch any of the digital outputs on, when a low level in an analog input is sensed. This feature is normally used for low-limit temperature or anti-freeze protection in rooms by switching on heating devices. The Low Limit mode overrides the OFF mode of the controller and the manual override of the 3-speed fan outputs.

Note: As the Low Limit mode is dependent on application and configuration, the equipment installer is responsible for ensuring that appropriate additional anti-freeze devices have been installed to cover all possible low temperature situations which may cause equipment damage.

For further details, refer to the *Low Limit Module Configuration* section of this document.

**Summer/Winter
Compensation**

The working set points in the TC-9100 Universal Controller may be increased in summer and decreased in winter to provide additional energy savings when it is possible and appropriate to modify comfort conditions in the controlled space.

Alternatively, in winter, the set points may be increased to offset the effect of “cold radiation” from external wall surfaces.

For further details, refer to the *Summer/Winter Compensation Module Configuration* section of this document.

Auto-dial Mode

The TC-9100 Universal Controller may signal to a supervisory system that any one or more of the following off-normal conditions has occurred:

- Analog Input High or Low Limit alarm
- Window open
- General alarm
- Low Limit (Anti-freeze) mode is active.

This signal may be used to initiate further actions, such as an automatic dial connection to a remote monitoring system. The N2 Dial Module (NDM101) within the Metasys System provides this function. For further details, refer to the section of this document titled *Auto-dial Feature*.

Software Configuration

Preparing a Configuration

The software operating system of the TC-9100 Universal Controller contains a number of modules which can be given operating and configuration parameters and connected together to perform the desired control function. Some of the modules condition physical inputs to provide data to other controlling and calculation modules, and some modules control the physical outputs, and the behaviour of all modules is determined by the operating parameters. The modules are shown graphically in *Appendix 2 – Worksheet 1 – Connections*, and the configuration of each type of module is described in detail in the following sections.

Parameter and connection data are stored in memory locations known as “Items.” A complete list of all the Items is given in *Appendix 1 – Table 1*. All Items have an address (given in hexadecimal and decimal notation) and a tag for easy identification. Some Items contain analog information in the form of numbers, some contain logical information in the form of eight binary states (one byte) or 16 binary states (two bytes), and some contain an integer number which is the address of another Item and defines a “connection” between modules. The source of the connection is the Item address of the analog output of a module and the destination of the connection is the Item address of an analog input of a module. The input (or destination) Items are identified by a tag with the “@” character. For example, the output of the module which measures Analog Input Number 1 is found at Item Address 01, and has the tag name AI1. The first input of Programmable Module Number 5 is found at Item Address 54 (hex) or 84 (decimal), and has the tag name PM5I1@. By entering the value 01 in Item Address 54 (hex), a connection is made, whereby the value of AI1 is transferred to the first input of Programmable Module Number 5 as shown below:

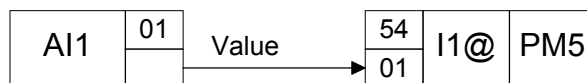

Connections to output modules are specified as part of the configuration parameter item for each module. The first 5 bits contain the Item address of the source of the connection. For example, when the Item Address 0A (hex) is entered into the first 5 bits of Item Address 78 (hex) or 120 (dec), the following connection is defined:

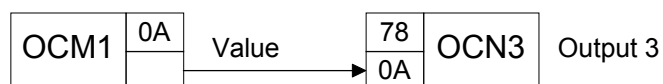

Worksheet 1 in *Appendix 2* can be used to develop a control strategy by making all the required connections graphically. The connection information can then be entered into the Item address locations in *Worksheets 2* and *3*. The parameters and data to define the operation of the various software modules can also be entered into these worksheets.

Entering a Configuration

When the worksheet has been completed, the data can be physically entered into the controller using the SM-9100 Service Module, which plugs into the side of the controller (or by connecting a PC to the N2 Bus serial link and running the M9101 Configuration and Commissioning Software Package). Using either tool, the data for each Item address is entered in turn. When complete, the controller operation may be monitored by displaying the Item addresses that contain the dynamic parameters of each module of the controller, such as analog input values, programmable module output values, or the Controller modes of operation.

Note: It is recommended that the controlled equipment be switched off when configuration parameters are being changed to avoid any unexpected control actions.

Analog Input Configuration (AI1 to AI4)

The TC-9100 Universal Controller has four analog inputs, each accepting a 0 to 10 VDC input signal. The inputs are conditioned in software using configuration parameters to provide a numerical value representing the physical quantity being measured, such as temperature, relative humidity, or flow rate. The numerical value can be used as an input to a programmable module (configured as a Control Module or a Calculation Module), and can be read by a supervisory system. Alarm limit values may be set in the controller, as fixed configuration parameters or by a supervisory system, and the high or low alarm status of each analog input can be read by a supervisory system.

Configuration Parameters

The parameters to be defined for each analog input are listed below. Refer to *Appendix 2 – Worksheet 3*, or *Appendix 1 – Table 1: Item List*, for the Item addresses. Note that *n* in the tag names in the table below stands for the analog input number from 1 to 4.

Table 4: Analog Input Configuration Items

Item Tag	Type	Description
IOPn	1 Byte	Analog Input Options that define the conditioning of the physical signal.
	Bit 4	Defines the physical input type and must be set to 0 (zero) for the voltage input.
	Bits 7,6,5	000 = Linear Range (0 to 10 V) 010 = Square Root Range (0 to 10 V) 011 = Linear Range (2 to 10 V)
	Bits 8,3,2,1	Set to 0 = not used.
HRIn	Number	High Range for AI_n : value represented by the highest input signal (10 VDC). (See LRIn for analog value calculation resulting from High and Low Range values.)
Continued on next page...		

Item Tag (Cont.)	Type	Description
LRIn	Number	<p>Low Range for AI_n: value represented by the lowest input signal (0 or 2 VDC). This value must be 0 for an input with the square root option. Use OFSn for zero offset correction. The analog value is calculated as follows:</p> <p>Linear: $AI = (PI\% + OFS) / 100 \times (HRI - LRI) + LRI$</p> <p>Square Root (LRI = 0): $AI = \sqrt{((PI\% + OFS)/100)} \times HRI$</p> <p>where: AI = Analog value PI% = Analog input in % of the physical input range (10 VDC, or 8 VDC for 2 to 10 V linear) OFS = Offset Value</p>
OFSn	Number	<p>Offset Value for AI_n: value added to the analog input in % of the physical input range. This parameter is normally used to offset an input to the square root range from a differential pressure transducer, for example, where the output of the transducer is not at “true zero” (0 or 2 VDC) when the physical differential pressure is zero. (See LRIn for analog value calculation using OFSn.)</p>
FTCn	Number	<p>Filter Time Constant: (in seconds) to reduce cyclic instability or rapid changes in the analog input. The effect of the filter is as follows: $AI_t = AI_{t-1} + [1 / (1 + FTC)] \times (AI - AI_{t-1})$</p> <p>where: AI_t = Filtered analog value at current time AI_{t-1} = Filtered analog value at previous poll AI = Actual analog value at current time</p> <p>If FTC = 0: AI_t = AI</p>
HIA _n	Number	<p>High Alarm Value for AI_n: if no high limit is required, enter a number greater than HRI_n.</p>
LOA _n	Number	<p>Low Alarm Value for AI_n: if no low limit is required, enter a number lower than LRI_n.</p>

If an analog input is configured but not connected to a sensor, install a wire jumper between the input terminal and the analog common terminal to keep the analog input at its low range value.

Dynamic Parameters

The parameters that are dynamically generated by the controller from the analog inputs using the configuration parameters are listed below:

Table 5: Analog Input Dynamic Items

Item Tag	Item Address (Hex/Dec)	Description
AI1	01/01	Analog Input 1 Value
AI2	02/02	Analog Input 2 Value
AI3	03/03	Analog Input 3 Value
AI4	04/04	Analog Input 4 Value
AIH1	1E/30, Bit 1	1 = Analog Input 1 High Alarm 0 = No high alarm
AIL1	1E/30, Bit 2	1 = Analog Input 1 Low Alarm 0 = No low alarm
AIH2	1E/30, Bit 3	1 = Analog Input 2 High Alarm 0 = No high alarm
AIL2	1E/30, Bit 4	1 = Analog Input 2 Low Alarm 0 = No low alarm
AIH3	1E/30, Bit 5	1 = Analog Input 3 High Alarm 0 = No high alarm
AIL3	1E/30, Bit 6	1 = Analog Input 3 Low Alarm 0 = No low alarm
AIH4	1E/30, Bit 7	1 = Analog Input 4 High Alarm 0 = No high alarm
AIL4	1E/30, Bit 8	1 = Analog Input 4 Low Alarm 0 = No low alarm

An alarm bit is set when the analog value is equal to the high or low alarm value, and the alarm bit is cleared when the analog value comes back into normal range by at least 2% of the range of the analog input, defined by [HRI - LRI].

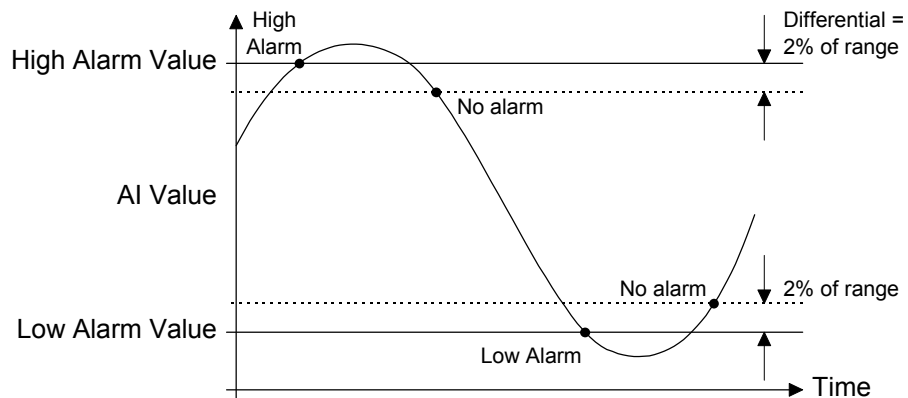

Figure 3: High and Low Alarms

When an analog input goes into high or low alarm, the DIAL Item bit is set. For details, refer to the section titled *Auto-dial Feature* in this document.

Digital Input Configuration (DI1 and DI2)

The TC-9100 Universal Controller has two digital inputs, labeled DI1 and DI2, each connecting to an isolated, voltage-free contact. DI1 may also be connected to a Condensation Sensor, Order Code HX-9100-8001, which provides the equivalent of an open contact when the sensor is dry and a closed contact when water condensation is sensed.

By configuration, the digital inputs are set to provide any two of the Logic modes in the controller which each have a specific function in the controller operation. The status of the Logic modes can be read by a supervisory system.

Configuration Parameters

The parameters to be defined for each digital input are listed below. The Item TCS2 is included in *Worksheet 3 of Appendix 2*.

Table 6: Digital Input Configuration Items

Item Tag	Type	Description
TCS2	2 Bytes Bits 11,10,9	Controller Options 2. Define Digital Input DI1 Logic mode , as follows: 000 = Input not used. 001 = Connected to a window contact for “Window Open” mode. 010 = Connected to an occupancy sensor for “Occupancy” mode. 011 = Connected to an air quality sensor, condensation sensor, or other sensor with override function for “Air Quality / Override” mode. 100 = Connected to a contact to change the action of one or more control modules for “Reverse Action” mode. 101 = Connected to a general purpose alarm contact for “General Alarm” mode. This mode has no effect on the operation of the controller and is used for supervisory system purposes only.
	Bit 12	Defines the action of the contact connected to DI1. 0 = “Open” contact sets the mode. 1 = “Closed” contact sets the mode. For example, for a “window” contact that opens when the window is open, set this bit to 0. For an “occupancy” sensor contact that closes to indicate occupancy, set this bit to 1.
	Bits 15...13	Define Digital Input DI2 Logic mode , using the same bit patterns as shown above for DI1, bits 11, 10, 9.
	Bit 16	Defines the action of the contact connected to DI2, the same as shown above for DI1, Bit 12.

The Logic mode set for DI2 must be different from the Logic mode of DI1 to avoid interference between the contacts. If an input is not used, set the Logic mode bits to 000. If a Logic mode is configured but no sensor contact is connected, install a wire jumper between the digital input terminals.

The Window Open and Occupancy modes are always active, if defined, and influence the controller operating mode (see tables 2 and 3). The Air Quality / Override and Reverse Action modes are only active for the control modules within which they are enabled. Programmable modules configured as Algorithm 7 to 12 (calculation modules) can be conditioned by one or both of the configured logic modes, enabling the digital inputs to be part of the calculation function (see *Programmable Modules Configuration – Calculation Algorithms*).

Dynamic Parameters

The parameters that are dynamically generated by the controller from the digital inputs using the configuration parameters are listed below:

Table 7: Digital Input Dynamic Items

Item Tag	Item Address (Hex/Dec)	Description
WIN	20/32, Bit 6	1 = Window open. 0 = Window closed.
OCC	20/32, Bit 7	1 = Occupied status. 0 = Unoccupied status.
AIRQ	20/32, Bit 8	1 = Air quality poor, condensation detected, or other override condition. 0 = No override condition.
REVL	26/38, Bit 3	1 = Reverse control action of enabled control modules. 0 = Use configured control action in enabled modules.
ALM	26/38, Bit 5	1 = General purpose alarm or status. 0 = Normal status.

When a Window Open or General Alarm status is detected, the DIAL Item bit is set. For details, refer to the section titled *Auto-dial Feature* in this document.

Output Module Configuration (OCN1 to OCN7)

The TC-9100 Universal Controller has seven output modules. Output modules OCN1 and OCN2 drive analog outputs or digital outputs, depending on model number. Output modules OCN3 to OCN7 drive digital (triac) outputs in both models.

Model **TC-9100-x000** has analog outputs, and OCN1 and OCN2 must be configured for 0-10V analog outputs. **(The option for solenoid valve driver module outputs is no longer used.)**

Model **TC-9100-x001** has all digital (triac) outputs, and OCN1 and OCN2 must be configured for one of the digital output options: as a pair for Position Adjust Type (PAT), or 2-stage on/off output type, or as two independent on/off outputs. OCN1 may also be configured as a Duration Adjust Type (DAT) and OCN2 as an on/off type.

In both models the digital output pairs OCN3/OCN4 and OCN5/OCN6 can be configured as one of the digital (triac) output options mentioned above for OCN1/OCN2. In addition, the digital outputs OCN5/OCN6/OCN7 can be configured as a 3-speed fan controller, and OCN7 has a special option as a “COMFORT” output signal when not used in the 3-speed fan control option.

The output modules provide the interface between the output of a programmable module and the hardware output. The status of the digital (triac) outputs can be read by a supervisory system and can be switched on and off directly by the supervisory system, overriding the output module. Digital outputs are normally only controlled by a supervisory system when not used in the controller configuration and provide a convenient means of remote switching. Analog outputs cannot be read or overridden by a supervisory system. However, the output of the programmable module from which the output module receives its control value may be read and overridden by a supervisory system (see *Programmable Modules Configuration*).

Analog Output Type (0 to 10 VDC)

The analog output type is only configurable in output modules OCN1 and OCN2 must be configured for 0 - 10 VDC. **(The option for a solenoid valve driver module output is no longer used).**

The analog hardware output for OCN1 has a special feature. There are in fact two physical analog outputs that are labeled AO1a and AO1b. Only one output can be active at one time and the other output will remain with a zero output. These outputs are typically used in a heating/cooling application with one controlled (process) variable, such as room temperature. AO1a is used to control the heating equipment and AO1b is used to control the cooling equipment, both of which directly influence the temperature measured by the controlled (process) variable. In order to use this special feature, the source control signal for OCN1 must come from a pair of programmable modules configured as Algorithm 4 (heating/cooling PI controller - single output). AO1a (heating) will be active when the first module of the pair (loop 1) is active, and AO1b (cooling) will be active when the second module of the pair (loop 2) is active. (See *Programmable Module Configuration – Algorithm 4* for details.)

If OCN1 is connected to a programmable module configured as an Algorithm 2 or 6, only output AO1a will be active. If OCN1 is connected to a programmable module configured as an Algorithm 7 to 13, only output AO1b will be active.

Analog output OCN2 may be connected to any programmable module. For all analog outputs, a range of 0 to 100% is assumed, where 0% gives a zero output and 100% gives the maximum output (10 VDC). OCN1 and OCN2 are not normally used with the on/off control algorithms 1, 3, and 5, since the output is either 0% or 100% and does not vary between these two limits.

Duration Adjust Type (DAT)

The DAT output type may be configured in output modules OCN1, OCN3, and OCN5. The DAT output is a digital output (triac) that is switched on for a duration within the set heating or cooling valve cycle time in direct proportion to the controller output from 0 to 100%. To avoid unnecessary switching of the valve actuator when the output is between 0 and 5% the digital output (triac) remains off, and when the output is between 95 and 100% the digital output (triac) remains on. The cycle time is set as a configuration parameter. DAT output modules may be connected to any programmable module except those configured as Algorithm 1, 3, or 5.

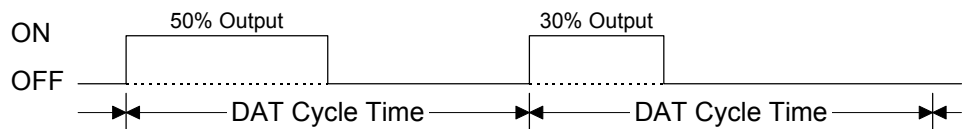

Figure 4: DAT Output

Position Adjust Type (PAT)

The PAT output type may be configured in pairs of output modules – OCN1/OCN2, OCN3/OCN4, and OCN5/OCN6.

The PAT output is a pair of digital outputs (triacs) that are switched on to open and close an incrementally driven heating or cooling valve. The duration of switching is directly proportional to the change in the controller output and related to the full stroke time of the valve such that a 100% change will completely open or close the valve. At the 0% or 100% position, the duration of switching is increased to ensure that the valve is completely at its end position and the appropriate digital output is switched on for the full stroke time every two hours to ensure that the valve remains at its end position. To prevent unnecessary wear on the actuator, the digital output will only be switched when the output change exceeds the PAT dead-band (in % of full stroke) in the same direction as the previous change, or twice the PAT dead-band if the direction of change is reversed. The full stroke time and PAT dead-band are set as configuration parameters. PAT output modules may be connected to any programmable module except those configured as Algorithm 1, 3, or 5.

2-Stage On/Off

The 2-stage on/off output type may be configured in pairs of output modules – OCN1/OCN2, OCN3/OCN4, and OCN5/OCN6.

The output is a pair of digital outputs (triacs) that are switched on in sequence as the controller output increases. The first stage digital output is switched as soon as the output is above 0% and the second stage digital output is switched when the output is equal to the set load rating for the first stage, which is set as a configuration parameter along with the switching differential.

Note: To ensure that the first stage switches off, the low limit of the control module to which the 2-stage output module is connected must be set at the switching differential value as a negative number. For example, if the differential is set at 5%, then the low limit of the control module must be set at -5%.

Two-stage output modules may be connected to programmable modules configured as Algorithm 2, 4, or 6, or as calculation algorithms 7 to 12, provided that the output range covers the switching differential, as explained above.

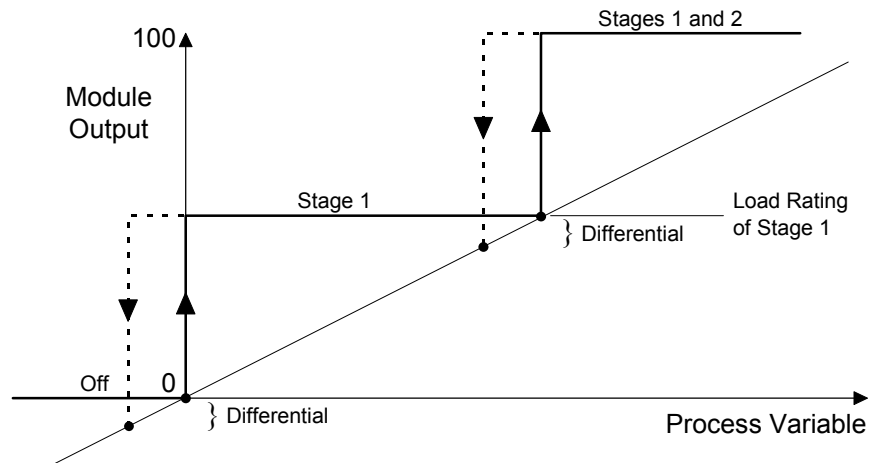

Figure 5: 2-Stage On/Off Output

On/Off Output Type

An on/off output type may be configured for output modules OCN1 to OCN6. The output is a single triac that is switched on when its source signal is greater than 0, and switched off when the source signal is equal to or less than 0. The on/off output module is normally connected to a programmable module configured as Algorithm 1, 3, or 5 (an on/off controller), and the switching differential is provided by the on/off controller.

3-Speed Fan Controller Output

The 3-speed fan controller output may be configured only in Output Module OCN5, and it also uses OCN6 and OCN7.

The output is a set of three digital outputs (triacs) that are switched on in turn at the three fan speed break points, set as configuration parameters. The switching differential for all break points is also set as a configuration parameter. The first output switches on at Break Point 1 and off at Break Point 1 less the switching differential. The second output switches on at Break Point 2 and the first output is switched off. The third output switches on at Break Point 3 and the second output is switched off. Only one output is on at one time, and the switching differential is applied to all on/off transitions.

The 3-speed fan controller output may be connected to any programmable module except those configured as Algorithm 1, 3, or 5.

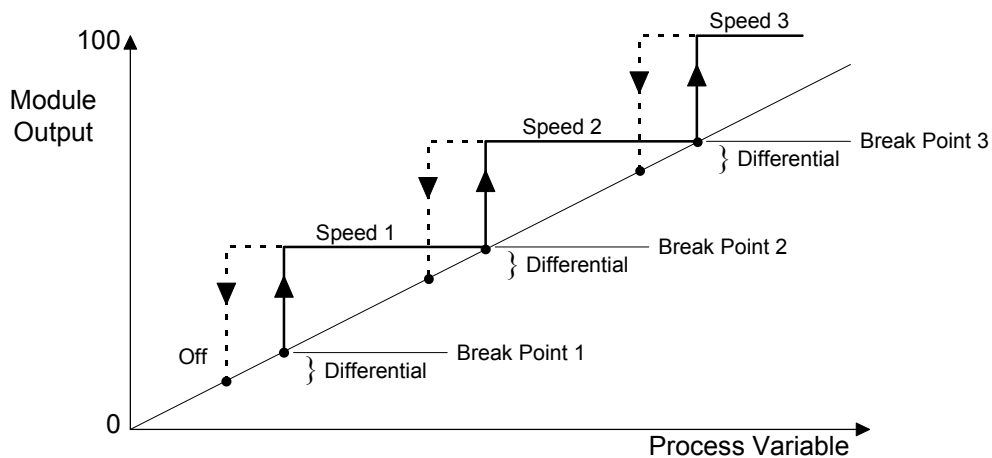

Figure 6: 3-Speed Fan Output

3-Speed Fan Override

When OCN5 is configured as a 3-speed fan controller, the source control signal connection to OCN6 defines an analog input that overrides the controller, as follows:

- Analog input value to OCN6 less than 0 \Rightarrow Automatic mode (3-speed fan module controlled by source defined in OCN5).
- Analog input value to OCN6 between 0 and 100 \Rightarrow Override mode (3-speed fan module controlled by analog input value to OCN6).

The output triacs switch at the defined break points and use the defined switching differential in both Automatic and Manual modes. The Override feature enables the manual control of fan speed using an analog input connected, for example, to a switch assembly that generates the voltage levels to force the appropriate fan speed or allow automatic operation.

Alternatively, the TM-9180 can be used to override the 3-speed fan controller. Refer to *Configuration for a TM-9180 Room Command Module*, further in this manual, for configuration details.

- Note 1: The Override mode is disabled when the controller is in Low Limit (Anti-freeze) mode or in OFF mode. In this case, the 3-speed fan controller operates in Automatic mode and responds as required by the programmable module to which it is connected.
- Note 2: In controllers with Version 3 or later firmware (Date Code 9714 or later), the Override mode is also disabled in NIGHT and STANDBY modes. The override is only active in COMFORT mode.
- Note 3: In controllers with Version 3 or later firmware (Date Code 9714 or later), a programmable module with a controller algorithm (algorithms 1-6) can be configured to set its output to 0 % (or OFF) when the 3-speed fan override sets the fan to OFF. This interlock is required for applications where heating or cooling equipment must be switched off when there is no air flow, such as in fan coil units with electric heating, direct expansion coils or heat pumps. Refer to *Configuration Parameters for Controller Algorithms* (PM Tag PMxTYP Bit 10), further in this manual, for details.

Output Module OCN7

When Output Module OCN7 is not used by Output Module OCN5 as the third speed of a 3-speed fan controller, the triac may be driven on when the operating mode of the controller is COMFORT by setting Bit 8 in Item TCS2 (Address 85 hex, 133 dec) to 1. This output can be used, for example, for lighting control.

Configuration Parameters

The parameters to be defined for each output module are listed below. Refer to *Appendix 2 – Worksheet 3*, or *Appendix 1 – Table 1: Item List*, for the Item addresses.

Note: Do not forget to set Item TCS2, Bit 6, according to the power supply frequency of 50 or 60 Hz.

Table 8: Output Module Configuration Items

Item Tag	Type	Description
TCS2	Bit 6	Set to 1 if the power supply frequency is 60 Hz, or set to 0 for 50 Hz.
	Bit 8	Set to 1 if OCN7 is not used for 3-speed fan control and DO7 should be on when the controller is in COMFORT mode.
OCN1	1 Byte Bits 5...1	Output Module 1 Configuration. Source of Module in binary code: 01010 (0A hex) = Output Module 1 (OCM1). 01011 (0B hex) = Output Module 2 (OCM2). ↓ 01111 (0F hex) = Output Module 6 (OCM6).

Continued on next page...

Item Tag (Cont.)	Type	Description
OCN1	Bits 8...6	<p>Output Type</p> <p>000 = Output not used.</p> <p>Hardware analog outputs only:</p> <p>001 = Not used. (Was for solenoid valve driver module.)</p> <p>010 = 0 to 10 VDC output.</p> <p>Hardware digital outputs (triac) only:</p> <p>011 = On/off output.</p> <p>100 = DAT output.</p> <p>101 = PAT output (also uses OCN2 – define OCN2 as “output not used”).</p> <p>110 = 2-stage output (also uses OCN2 – define OCN2 as “output not used”).</p>
OCO1	Number	<p>Output Module 1 Parameter.</p> <p>When OCN1 is PAT = Full stroke time of actuator (sec.).</p> <p>When OCN1 is DAT = Cycle time of actuator (sec.).</p> <p>When OCN1 is 2-stage = Load rating of stage 1 (% of module output).</p>
OCN2	1 Byte Bits 5...1 Bits 8...6	<p>Output Module 2 Configuration.</p> <p>Source of Module in binary code:</p> <p>01010 (0A hex) = Output Module 1 (OCM1).</p> <p>01011 (0B hex) = Output Module 2 (OCM2).</p> <p style="text-align: center;">↓</p> <p>01111 (0F hex) = Output Module 6 (OCM6).</p> <p>Output Type</p> <p>000 = Output not used (or used with PAT or 2-stage output defined in OCN1).</p> <p>Hardware analog outputs only:</p> <p>001 = Not used. (Was for solenoid valve driver module.)</p> <p>010 = 0 to 10 VDC output.</p> <p>Hardware digital outputs (triac) only:</p> <p>011 = On/off output.</p>
OCO2	Number	<p>Output Module 2 Parameter.</p> <p>When OCN1 is PAT = PAT dead-band (%).</p> <p>When OCN1 is 2-stage = Switching differential (%).</p>
OCN3	1 Byte Bits 5...1 Bits 8...6	<p>Output Module 3 Configuration.</p> <p>Source of Module in binary code:</p> <p>01010 (0A hex) = Output Module 1 (OCM1).</p> <p>01011 (0B hex) = Output Module 2 (OCM2).</p> <p style="text-align: center;">↓</p> <p>01111 (0F hex) = Output Module 6 (OCM6).</p> <p>Output Type</p> <p>000 = Output not used.</p> <p>011 = On/off output.</p> <p>100 = DAT output.</p> <p>101 = PAT output (also uses OCN4 – define OCN4 as “output not used”).</p> <p>110 = 2-stage output (also uses OCN4 – define OCN4 as “output not used”).</p>
Continued on next page...		

Item Tag (Cont.)	Type	Description
OCO3	Number	Output Module 3 Parameter. When OCN3 is PAT = Full stroke time of actuator (sec.). When OCN3 is DAT = Cycle time of actuator (sec.). When OCN3 is 2-stage = Load rating of stage 1 (% of module output).
OCN4	1 Byte Bits 5...1 Bits 8...6	Output Module 4 Configuration. Source of Module in binary code: 01010 (0A hex) = Output Module 1 (OCM1). 01011 (0B hex) = Output Module 2 (OCM2). ↓ 01111 (0F hex) = Output Module 6 (OCM6). Output Type 000 = Output not used (or used with PAT or 2-stage output defined in OCN3). 011 = On/off output.
OCO4	Number	Output Module 4 Parameter. When OCN3 is PAT = PAT dead-band (%). When OCN3 is 2-stage = Switching differential (%).
OCN5	1 Byte Bits 5...1 Bits 8...6	Output Module 5 Configuration. Source of Module in binary code: 01010 (0A hex) = Output Module 1 (OCM1). 01011 (0B hex) = Output Module 2 (OCM2). ↓ 01111 (0F hex) = Output Module 6 (OCM6). Output Type 000 = Output not used. 011 = On/off output. 100 = DAT output. 101 = PAT output (also uses OCN6 – define OCN6 as “output not used”). 110 = 2-stage output (also uses OCN6 – define OCN6 as “output not used”). 111 = 3-speed fan control (also uses OCN6 and OCN7 – define OCN6 and OCN7 as “output not used”).
OCO5	Number	Output Module 5 Parameter. When OCN5 is PAT = Full stroke time of actuator (sec.). When OCN5 is DAT = Cycle time of actuator (sec.). When OCN5 is 2-stage = Load rating of stage 1 (% of module output). When OCN5 is 3-speed fan control = Fan speed Break Point 1 (% of module output, must be lower than Break Point 2).
Continued on next page...		

Item Tag (Cont.)	Type	Description
OCN6	1 Byte Bits 5...1 Bits 8...6	<p>Output Module 6 Configuration.</p> <p>Source of Module in binary code: 01010 (0A hex) = Output Module 1 (OCM1). 01011 (0B hex) = Output Module 2 (OCM2). ↓ 01111 (0F hex) = Output Module 6 (OCM6). When OCN5 is 3-speed fan control, the fan override source is defined here: 00001 (01 hex) = AI1. ↓ 00100 (04 hex) = AI4.</p> <p>Output Type 000 = Output not used (or used with PAT or 2-stage output or 3-speed fan control defined in OCN5). 011 = On/off output.</p>
OCO6	Number	<p>Output Module 6 Parameter.</p> <p>When OCN5 is PAT = PAT dead-band (%). When OCN5 is 2-stage = Switching differential (%). When OCN5 is 3-speed fan control = Fan speed Break Point 2 (% of module output, must be higher than Break Point 1 and lower than Break Point 3).</p>
OCN7	1 Byte Bits 5...1 Bits 8...6	<p>Output Module 7 Configuration.</p> <p>Fan Speed Differential in binary code: (1 to 31%, e.g., 10% = 01010 binary). Set to 000.</p>
OCO7	Number	<p>Output Module 7 Parameter.</p> <p>Fan speed Break Point 3 (% of module output, must be higher than Break Point 2).</p>

Dynamic Parameters

The parameters that are dynamically generated by the controller from the Output Modules and the associated hardware outputs are listed below:

Table 9: Output Module Dynamic Items

Item Tag	Item Address (Hex/Dec)	Description
DO1	1F/31, Bit 6	1 = Digital Output 1 On 0 = Digital Output 1 Off
DO2	1F/31, Bit 7	1 = Digital Output 2 On 0 = Digital Output 2 Off
DO3	1F/31, Bit 1	1 = Digital Output 3 On 0 = Digital Output 3 Off
DO4	1F/31, Bit 2	1 = Digital Output 4 On 0 = Digital Output 4 Off
DO5	1F/31, Bit 3	1 = Digital Output 5 On 0 = Digital Output 5 Off
DO5	1F/31, Bit 4	1 = Digital Output 6 On 0 = Digital Output 6 Off
DO7	1F/31, Bit 5	1 = Digital Output 7 On 0 = Digital Output 7 Off
FOV	26/38, Bit 7	1 = 3-Speed fan override active. 0 = 3-Speed fan in Normal/Automatic mode.

The status of a digital output represents the actual status of the hardware triac, and is generally only used to monitor on/off, 2-stage, or 3-speed fan control type outputs. For PAT and DAT outputs, the status of the triacs is dependent on momentary control requirements and the monitoring of the triacs is normally only useful for commissioning and troubleshooting purposes.

Since there are no analog dynamic parameters generated by the output modules, it is recommended that for analog output types, PAT, and DAT, the analog source values from the outputs of the programmable modules be monitored (OCM1 to OCM6).

**Programmable
Module
Configuration
(PM1 to PM6)**

The TC-9100 Universal Controller has six programmable modules that may be configured to operate in accordance with one of the 13 algorithms available in the controller operating system. Algorithms 1 to 6 are controller algorithms, and algorithms 7 to 13 are calculation algorithms. All programmable modules have the same set of configuration parameters, which are listed in *Appendix 1 – Table 1: Item List, Programmable Module Configuration Parameters*, each with a generic or “PM Tag” name.

Each programmable module has one Item to define its type and its options (PMnTYP, n = 1 to 6), 3 Items to define three source signal (or input) connections (PMnI1@, PMnI2@, and PMnI3@, n = 1 to 6), and 7 operating parameters (PMnKm, n = 1 to 6 and m = 1 to 7). Each programmable module also has an output that may be read by a supervisory system at Items OCM1 to OCM6 (Item addresses 0A to 0F hex). These Items are normally used as source signals (or inputs) to Output Modules or other programmable modules.

The source signal connections to the programmable modules are normally one of the analog inputs (AI1 to AI4) or the outputs of other programmable modules. When a programmable module is given an algorithm number (which is entered into the PMnTYP Item), each Item is also given an alias, or “Alg. Tag,” and a specific function within the selected algorithm, as described in *Appendix 1 – Table 2: Programmable Module Algorithms*.

**Controller
Algorithms
1 to 6 –
General**

Note: The tag names described in the sections that follow are the algorithm aliases (or Alg Tags) assigned by each algorithm to the generic programmable module parameters. For example, when the On/Off Controller Algorithm is used for a programmable module, the generic PMnK3 parameter is called the switching differential (DIF).

On/Off Controller

When configured as an on/off controller, the programmable module continuously compares its Input I1, known as the Process Variable (PV), with its Working Set Point (WSP), and switches its output (OCM) from 0% to 100% when the PV is equal to or **greater** than the WSP for a direct-acting controller, or from 0% to 100% when the PV is equal to or **less** than the WSP for a reverse-acting controller. A switching differential (DIF) is defined in each case in units of the process variable.

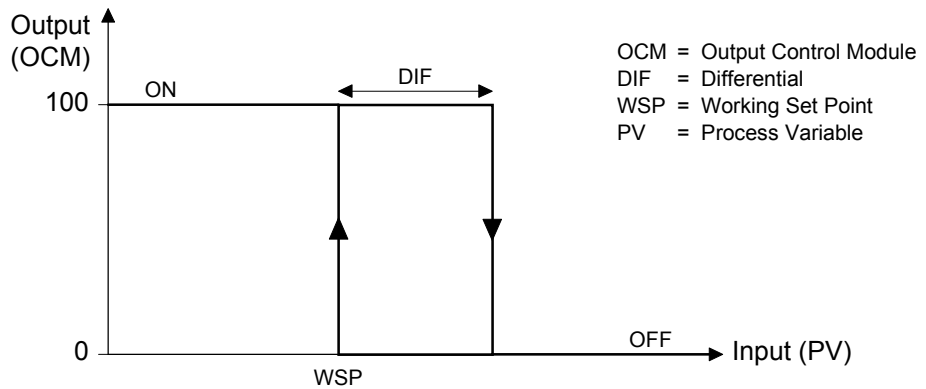

Figure 7: Reverse-acting (Heating) On/Off Controller

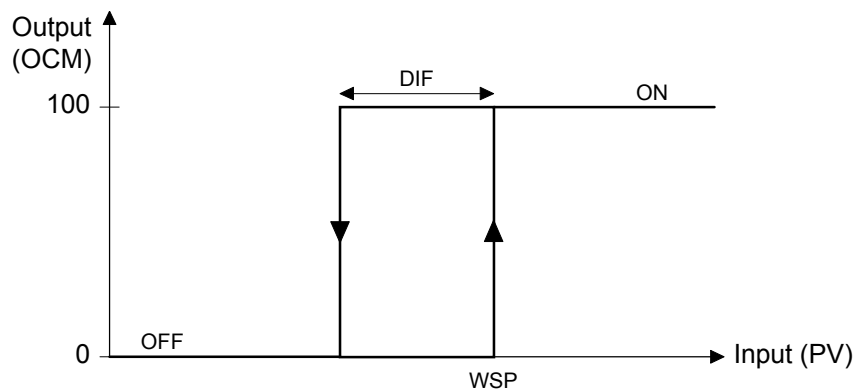

Figure 8: Direct-acting (Cooling) On/Off Controller

Proportional/Integral (PI) Controller

When configured as a PI controller, the programmable module continuously compares its Input I1, known as the process variable (PV), with its Working Set Point (WSP), and linearly increases its output (OCM) from 0% when the PV is equal to the WSP, to 100% when the PV *exceeds* the WSP by a value equivalent to the proportional band (PB) for a direct-acting controller, or from 0% when the PV is equal to the WSP, to 100% when the PV is *less than* the WSP by a value equivalent to the Proportional Band (PB) for a reverse-acting controller.

The proportional band is defined as a percentage of the range of the process variable. For an analog input, the range is defined as the difference between the High Range Input (HRI) and the Low Range Input (LRI). See *Analog Input Configuration* for details. For example, if HRI = 40 and LRI = 10, the range of the process variable is $(40 - 10) = 30$. A proportional band of 100% is then equivalent to 30 units of the process variable, and a PB of 10% is equivalent to 3 units of the PV. If the process variable is the output of a programmable module, the range is fixed at 100 and the proportional band is in units of the output signal.

An Integral Action Time (TI) in “repeats per minute” may be defined for a direct-acting or reverse-acting controller. When TI is set to zero, the integral action is disabled. The integral action creates an “integral term,” which is added to the “proportional term” created by the proportional action.

The following equations define the operation of the PI controller:

$$\text{Proportional Term (P}_t) = (PV_t - WSP) \times \frac{100}{PB} \times \frac{100}{R}$$

$$\text{Integral Term (I}_t) = I_{t-1} + (PV_t - WSP) \times \frac{100}{PB} \times \frac{100}{R} \times \frac{TI}{60}$$

$$\text{Controller Output (OCM}_t) = P_t + I_t$$

where

OCM_t , P_t , I_t , and PV_t are values at the current time t ,

I_{t-1} is the value one second earlier than the current time,

$R = (HRIn - LRIn)$ when PV is connected to AIn ($n=1-4$),

or $R = 100$ when PV is connected to $OCMn$.

The output of the PI controller may be limited between high and low limit values.

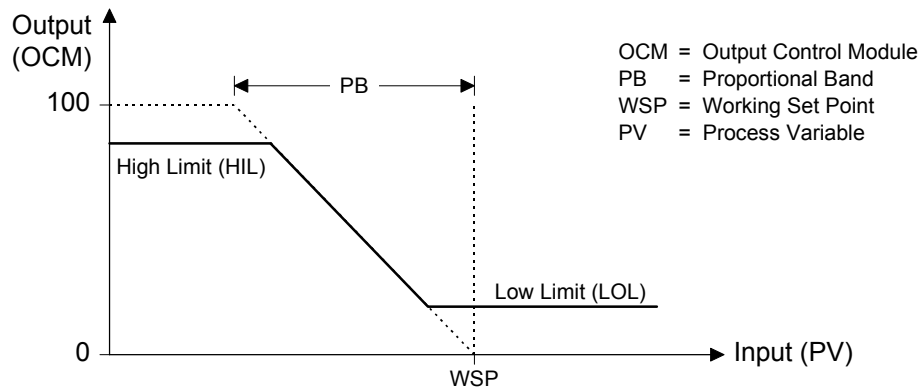

Figure 9: Reverse-acting (Heating) PI Controller

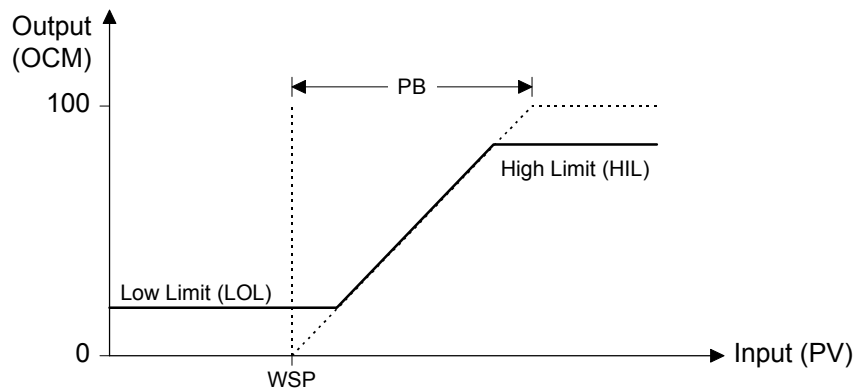

Figure 10: Direct-acting (Cooling) PI Controller

Working Set Point (WSP)

The working set point of a controller is calculated from the internal set point of the controller called the Local Set Point (LSP), Input I2 known as the Remote Set Point (RS), and Input I3 known as the Reference Variable (RV). When the controller is in STANDBY mode or NIGHT mode, an additional parameter is used in the calculation, known as the “Set Point Bias During Standby” (BSB), or the “Set Point Bias During Night” (BNT). These set point bias values will normally be negative numbers for heating controllers to reduce the WSP during standby or night periods, and positive numbers for cooling controllers to increase the WSP during standby and night periods. The working set point of a controller is given by the following equations:

In COMFORT mode:

$$\text{WSP} = (\text{LSP} + \text{RS}) \times \text{RV}$$

In STANDBY mode:

$$\text{WSP} = (\text{LSP} + \text{RS}) \times \text{RV} + \text{BSB}$$

In NIGHT mode:

$$\text{WSP} = (\text{LSP} + \text{RS}) \times \text{RV} + \text{BNT}$$

Note: In OFF mode, the control module is calculated as in NIGHT mode but the control module will only operate if the OFF mode override for that control module has *not* been enabled.

The working set point is also shifted when the Winter or Summer Compensation function is enabled for the controller concerned. Refer to *Summer/Winter Compensation* for further details.

The working set points of programmable modules configured as controllers can be read by a supervisory system. Refer to *Supervisory Functions* for further details.

Error Dead Band in PI Controller

The error dead-band in a PI controller is defined by configuration as 1% or 0.1% of the proportional band. When the control error (PV - WSP) is less than the error dead-band, as a positive or negative number, the integral action of the controller is suspended and the integral term is not changed. This feature prevents unnecessary cycling of the output when the process variable is very close to the working set point, due to the slow increase of the integral term over time.

Controller Override Mode Priorities

The PI controller and on/off controller output may be overridden by one of several Override modes, which are described elsewhere in this manual. The priorities of these Override modes are:

Table 10: Override Priorities

Priority	Mode
1 (highest)	Manual OFF Fan Override (3-speed fan control)
2	Low Limit (Anti-freeze) mode
3	OFF mode (from window open or supervisory system shutoff)
4	Startup (from supervisory system)
5	Air Quality / Override mode (from digital input)

Note 1: The Manual OFF Override mode must not be enabled in the controller which is connected to the 3-speed fan output module.

Note 2: If the Low Limit mode is enabled in the controller which is connected to the 3-speed fan output module, then the Low Limit mode effectively has the highest priority as the fan will run at high speed in Low Limit mode, overriding a Manual OFF Override mode, if active.

Configuration Parameters for Controller Algorithms

The parameters to be defined for each programmable module using one of the controller algorithms are listed below. Refer to *Appendix 2 – Worksheet 2*, or *Appendix 1 – Table 1: Item List*, for the Item addresses. In the table below, x in the PM Tag name is the programmable module number from 1 to 6.

Table 11: Programmable Module Configuration Items for Controller Algorithms

PM Tag	Alg Tag	Type	Description
PMxK1	LSP	Number	Local Set Point: basic parameter for the working set point.
PMxI1@	PV@	Connection	Process Variable Source: 01 (hex) = Analog Input 1 (AI1). ↓ 1B (hex) = External Analog Input 6 (XAI6).
PMxI2@	RS@	Connection	Remote Set Point Source: (The value of RS = 0 if the connection = 00) 01 (hex) = Analog Input 1 (AI1). ↓ 1B (hex) = External Analog Input 6 (XAI6), or the Item address of any other “Number” type Item may be entered.
PMxI3@	RV@	Connection	Reference Variable Source: (The value of RV = 1 if the connection = 00). The Item address of any “Number” type Item may be entered.
Continued on next page...			

PM Tag (Cont.)	Alg Tag	Type	Description
PMxTYP	TYP	2 Bytes	<p>Algorithm Options define the behaviour of the programmable module.</p> <p>Bits 5...1 Algorithm Number in binary code: 00001 = Algorithm 1. ↓ 00110 = Algorithm 6.</p> <p>Bit 6 Enable Low Limit (Anti-freeze) Override for this module: 0 = Not enabled. 1 = Output set to 100% when low limit active (AFM=1).</p> <p>Bit 7 Enable Summer Compensation for this module: 0 = Not enabled. 1 = WSP increased by the Summer Compensation value SAC (Item Address 1D hex).</p> <p>Bit 8 Enable Winter Compensation for this module: 0 = Not enabled. 1 = WSP increased/decreased by the Winter Compensation value WAC (Item Address 1C hex).</p> <p>Bit 9 Enable OFF Override for this module: 0 = Not enabled. 1 = When the controller is in OFF mode, the output is set to 0% or the Low Limit value (LOL – PI controller only), whichever is lower.</p> <p>Bit 10 Enable Manual OFF Fan Override for this module: 0 = Not enabled. 1 = If “3-speed fan control” is configured in OCN5, the output of the controller is set to 0 % or Low Limit value (whichever is lower) when the fan is set to OFF by an override connection to OCN6 or by a TM-9180 Room Command Module. Do not set this bit if the controller is connected to Output Module OCN5.</p> <p>Bit 11 Enable Startup Override for this module: 0 = Not enabled. 1 = When the controller is commanded to start up by a supervisory system, the output is set to the level specified by the Startup Output Level (Bit 12).</p> <p>Bit 12 Startup Output Level for this module: 0 = Startup output level is 0% or Low Limit value (whichever is lower). 1 = Startup output level is 100%.</p>
Continued on next page...			

PM Tag (Cont.)	Alg Tag	Type	Description
PMxTYP		Bit 13 Bit 14 Bit 15 Bit 16	<p>Enable Air Quality / Override for this module: 0 = Not enabled. 1 = When the Air Quality/Override Mode (AIRQ) is active (Item Address 20 hex, Bit 8), the output is set to the level specified by the Air Quality/Override Output Level (Bit 14).</p> <p>Air Quality/Override Output Level for this module: 0 = Air Quality/Override output level is 0% or Low Limit value (whichever is lower). 1 = Air Quality/Override output level is 100%.</p> <p>Enable Reverse Action for this module: 0 = Action is set by Item PB (PI controller) or Item ACT (on/off controller). 1 = When Reverse Action (REVL) is active (Item Address 26 hex, Bit 3), either by a digital input or by a reverse action command (REVC, Item Address 87 hex, Bit 8) from a supervisory system, the action of the PI or on/off controller is reversed.</p> <p>Error Dead Band (for PI controller only): 0 = Error Dead Band is 0.1%. 1 = Error Dead Band is 1%.</p>
PMxK2	PB/ACT	Number	<p>Proportional Band for a PI controller. Positive number = Direct-acting (cooling). Negative number = Reverse-acting (heating). Enter value in % of PV range. See <i>Proportional/Integral (PI) Controller</i> above for further details.</p> <p>Action for an on/off controller. +1 = Direct-acting (cooling). -1 = Reverse-acting (heating).</p>
PMxK3	TI/DIF	Number	<p>Integral Timing for a PI controller. Enter value in repeats per minute. See <i>Proportional/Integral (PI) Controller</i> above for further details.</p> <p>Differential for an on/off controller. Enter value in units of the Process Variable.</p>
PMxK4	HIL	Number	High Limit value for the module output (OCM) in % (PI controller only).
PMxK5	LOL	Number	<p>Low Limit value for the module output (OCM) in % (PI controller only).</p> <p>When the controller is in OFF mode and the module is enabled for OFF mode, the output is set to 0% if the low limit is greater than 0%, or set to the low limit value if it is less than 0%.</p>
PMxK6	BSB	Number	Set Point Bias during STANDBY Mode. Value is normally positive for a cooling controller and negative for a heating controller.
PMxK7	BNT	Number	Set Point Bias during NIGHT Mode. Value is normally positive for a cooling controller and negative for a heating controller.

Dynamic Parameters for Controller Algorithms

The parameters that are dynamically generated by programmable modules configured to use controller algorithms are listed below:

Table 12: Programmable Module Dynamic Items for Controller Algorithms

Item Tag	Item Address (Hex/Dec)	Description
OCM1	0A/10	Output of Programmable Module 1
OCM2	0B/11	Output of Programmable Module 2
OCM3	0C/12	Output of Programmable Module 3
OCM4	0D/13	Output of Programmable Module 4
OCM5	0E/14	Output of Programmable Module 5
OCM6	0F/15	Output of Programmable Module 6
WSP1	10/16	Working Set Point of Control Module 1
WSP2	11/17	Working Set Point of Control Module 2
WSP3	12/18	Working Set Point of Control Module 3
WSP4	13/19	Working Set Point of Control Module 4
WSP5	14/20	Working Set Point of Control Module 5
WSP6	15/21	Working Set Point of Control Module 6

Algorithm 1: On/Off Controller

When a programmable module is configured as Algorithm 1 (Item PMxTYP, bits 5...1 = 00001), the module performs the function of an on/off controller.

Algorithm 2: PI Controller

When a programmable module is configured as Algorithm 2 (Item PMxTYP, bits 5...1 = 00010), the module performs the function of a PI controller.

Algorithm 3: Heating/Cooling On/Off Controller – Single Output

When a programmable module is configured as Algorithm 3 (Item PMxTYP, bits 5...1 = 00011), the module works with the next programmable module (PMx+1) as a heating/cooling on/off controller with a single output. The output of the second module (Loop 2) follows the output of the first module (Loop 1).

Loop 1 must be configured as a heating controller (reverse acting) and its working set point must always be lower than the working set point of Loop 2, which must be configured as a cooling controller (direct acting). The two modules share the process variable of Loop 1. Loop 1 is active when the process variable is below the working set point of Loop 1, and Loop 2 is active when the process variable is above the working set point of Loop 2. The changeover takes place in the center of the control dead-band between the two loops with a 10% switching differential.

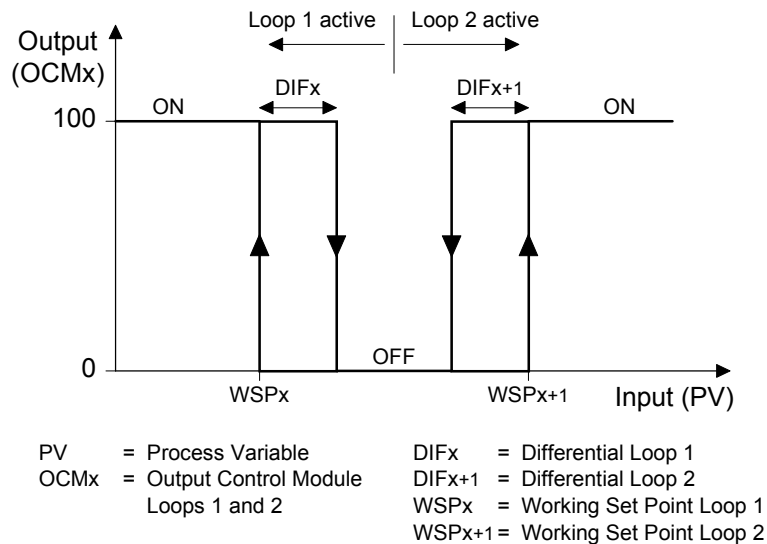

Figure 11: Heating/Cooling On/Off Controller – Single Output

**Algorithm 4:
Heating/Cooling
PI Controller –
Single Output**

When a programmable module is configured as Algorithm 4 (Item PMxTYP, bits 5...1 = 00100), the module works with the next programmable module (PMx+1) as a heating/cooling PI controller with a single output. The output of the second module (Loop 2) follows the output of the first module (Loop 1).

Loop 1 must be configured as a heating controller (reverse acting) and its working set point must always be lower than the working set point of Loop 2, which must be configured as a cooling controller (direct acting). The two modules share the process variable of Loop 1. Loop 1 is active when the process variable is below the working set point of Loop 1, and Loop 2 is active when the process variable is above the working set point of Loop 2. The changeover takes place in the center of the control dead-band between the two loops with a 10% switching differential.

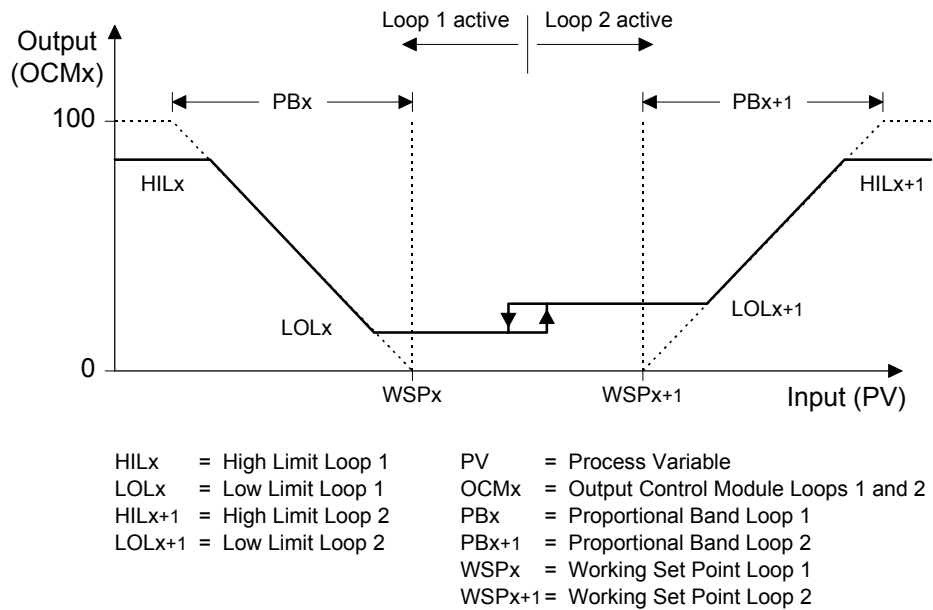

Figure 12: Heating/Cooling PI Controller – Single Output

The single output controller is used when the same equipment is modulated for heating and cooling, for example, a fan speed controller (where the Heating and Cooling modes are controlled by another controller). When there is separate equipment for heating and cooling, for example, a heating valve and a cooling valve, a dual output heating/cooling controller must be used (Algorithm 6).

**Algorithm 5:
Heating/Cooling
On/Off Controller
–
Dual Output**

When a programmable module is configured as Algorithm 5 (Item PMxTYP, bits 5...1 = 00101), the module works with the next programmable module (PMx+1) as a heating/cooling on/off controller with a dual output. The output of the first module (Loop 1) is active when Loop 1 is active, and is set to 0% when the loop is not active. Similarly, the output of the second module (Loop 2) is active when Loop 2 is active, and is set to 0% when the loop is not active.

Otherwise, the function of the algorithm is identical to Algorithm 3.

**Algorithm 6:
Heating/Cooling
PI Controller –
Dual Output**

When a programmable module is configured as Algorithm 6 (Item PMxTYP, bits 5...1 = 00110), the module works with the next programmable module (PMx+1) as a heating/cooling PI controller with a dual output. The output of the first module (Loop 1) is active when Loop 1 is active, and is set to 0% or to the Low Limit (whichever is lower) when the loop is not active, setting also the Integral Term to zero. Similarly, the output of the second module (Loop 2) is active when Loop 2 is active, and is set to 0% or to the Low Limit (whichever is lower) when the loop is not active.

Otherwise, the function of the algorithm is identical to Algorithm 4.

Note: When Programmable Module 1 is configured as Algorithm 3, 4, 5 or 6, the L1A bit of LSC (Item Address 26 hex, Bit 4) indicates when the module is active, i.e., when heating is active. When Programmable Module 3 is configured as Algorithm 3, 4, 5 or 6, the L3A bit of LSC (Address 26 hex, Bit 8) indicates when the module is active, i.e., when heating is active. Therefore, it is generally recommended to use programmable modules 1 and 2, or programmable modules 3 and 4, as heating/cooling controllers.

Algorithms 7 to 12: Calculation Modules

When a programmable module is configured as one of the Algorithms 7 to 12 (Item PMxTYP, bits 5...1 = 00111 to 01100), the module performs a calculation function. The calculation module uses up to three input connections (I1@, I2@ and I3@) to provide the inputs I1, I2 and I3, up to four constants (K2, K3, K4 and K5), and two “Conditioning Logic Variables,” which conditionally add two further constants (K6 and K7). The output is calculated in accordance with the equation for the algorithm, as follows:

Algorithm 7: Average

$$\text{Output (OCM)} = [(I1 \times K3 + I2 \times K4 + I3 \times K5) / K2 + A] \times B$$

(If an input is not connected, the corresponding value *In* will assume a default value of 1.)

Algorithm 8: Minimum

$$\text{Output (OCM)} = [K2 + \text{MIN}(I1 \times K3, I2 \times K4, I3 \times K5) + A] \times B$$

(If an input is not connected, the corresponding value *In* will be excluded from the calculation.)

Algorithm 9: Maximum

$$\text{Output (OCM)} = [K2 + \text{MAX}(I1 \times K3, I2 \times K4, I3 \times K5) + A] \times B$$

(If an input is not connected, the corresponding value *In* will be excluded from the calculation.)

Algorithm 10: Equation 1

$$\text{Output (OCM)} = \left[K2 + \frac{I1 \times K3 + I2 \times K4}{I3 + K5} + A \right] \times B$$

(If an input is not connected, the corresponding value *In* will assume a default value of 1.)

Algorithm 11: Equation 2

$$\text{Output (OCM)} = \left[K2 + \frac{(I1 + K3) \times (I2 + K4)}{I3 + K5} + A \right] \times B$$

(If an input is not connected, the corresponding value *In* will assume a default value of 1.)

Algorithm 12: Equation 3

$$\text{Output (OCM)} = [K2 \times (I1+K3) \times (I2+K4) \times (I3+K5) + A] \times B$$

(If an input is not connected, the corresponding value *In* will assume a default value of 1.)

In all of the above equations, the variables *A* and *B* are determined as follows:

$$\begin{aligned} A &= 0 && \text{if Conditioning Logic Variable 1} = 0 \\ A &= K6 && \text{if Conditioning Logic Variable 1} = 1 \\ B &= 1 && \text{if Conditioning Logic Variable 2} = 0 \\ B &= K7 && \text{if Conditioning Logic Variable 2} = 1 \end{aligned}$$

The “Conditioning Logic Variable” can be any one of the logic modes in the controller:

- Window Open
- Occupancy
- Air Quality/Override
- Reverse Action
- General Alarm
- Low Limit

This feature allows the digital inputs (DI1 and DI2) to the controller (or Low Limit mode) to have an influence on the operation of the controller. For example, a set point may be increased or decreased depending on an override or alarm condition, as detected by digital input DI1 or DI2.

**Configuration
Parameters for
Calculation
Algorithms
7 to 12**

The parameters to be defined for each programmable module using a calculation algorithm are listed below. Refer to *Appendix 2 – Worksheet 2*, or *Appendix 1 – Table 1: Item List*, for the Item addresses. In the table below, *x* in the PM Tag name is the programmable module number from 1 to 6.

Table 13: Calculation Algorithms 7 to 12 Configuration Items

PM Tag	Alg Tag	Type	Description
PMxK1	—	Number	Not used.
PMxI1@	I1@	connection	Input 1 (I1): (optional)*
PMxI2@	I2@	connection	Input 2 (I2): (optional)*
PMxI3@	I3@	connection	Input 3 (I3): (optional)* * When not connected, an input assumes a default value of 1, or is excluded from a MIN or MAX calculation.
PMxTYP	TYP	2 Bytes Bits 5...1 Bits 8...6 Bits 12...9 Bits 16...13	Algorithm Options define the behaviour of the programmable module. Algorithm Number in binary code: 00111 (07 hex) = Algorithm 7. ↓ 01100 (0C hex) = Algorithm 12. Not used. Define logic mode used by Conditioning Logic Variable 1 (values same as Variable 2 below) Define logic mode used by Conditioning Logic Variable 2: 0000 = none. 0001 = Window Open. 0010 = Occupancy Sensor. 0011 = Air Quality/Override. 0100 = Reverse Action. 0101 = General Alarm. 0110 = Low Limit (Anti-freeze).
PMxK2	K2	Number	Constant used in the calculation.
PMxK3	K3	Number	Constant used in the calculation.
PMxK4	K4	Number	Constant used in the calculation.
PMxK5	K5	Number	Constant used in the calculation.
PMxK6	K6	Number	Constant used in the calculation if Conditioning Logic Variable 1 is true.
PMxK7	K7	Number	Constant used in the calculation if Conditioning Logic Variable 2 is true.

Dynamic Parameters for Calculation Algorithms 7 to 12

The parameters that are dynamically generated by programmable modules configured to use calculation algorithms are listed below:

Table 14: Calculation Algorithms 7 to 12 Dynamic Items

Item Tag	Item Address (Hex/Dec)	Description
OCM1	0A/10	Output of Programmable Module 1
OCM2	0B/11	Output of Programmable Module 2
OCM3	0C/12	Output of Programmable Module 3
OCM4	0D/13	Output of Programmable Module 4
OCM5	0E/14	Output of Programmable Module 5
OCM6	0F/15	Output of Programmable Module 6

Algorithm 13: Line Segment Function

When a programmable module is configured as Algorithm 13 (Item PMxTYP, bits 5...1 = 01101), the module performs a line segment (or signal span) function. The module uses up to three input connections (I1@, I2@ and I3@) to provide the inputs I1, I2 and I3, which are added to give the input to the line segment or span function. Four constants define two break points for the line segment or span. If an input is not connected, it is excluded from the calculation.

An input can also be excluded (set to zero) whenever the mode of the controller is *not* COMFORT (i.e., the input is included only when the controller is in COMFORT), by enabling (setting to 1) the conditioning variable (CND1, CND2 or CND3) corresponding to the input number. This feature allows, for example, a remote set point adjust input to be active only in COMFORT mode. In the other modes (STANDBY, NIGHT and OFF), the remote set point adjust will be excluded and only the internal set points will be used for the calculation.

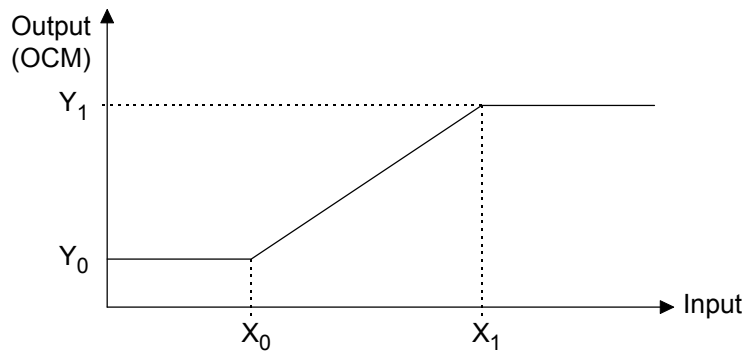

Figure 13: Line Segment Function

Input = I1 + I2 + I3, where:

$$I_n = 0 \quad \text{if } I_n@ \text{ is not connected,} \\ \text{or if } (CND_n \text{ is set}) \text{ AND } (\text{Mode} \neq \text{COMFORT}).$$

$$\text{When: } X_0 < \text{input} < X_1, \quad \text{output} = \frac{(\text{input} - X_0) \times (Y_1 - Y_0)}{X_1 - X_0} + Y_0$$

$$\text{When: } \text{input} \leq X_0, \quad \text{output} = Y_0$$

$$\text{When: } \text{input} \geq X_1, \quad \text{output} = Y_1$$

Configuration Parameters for Line Segment Algorithm

The parameters to be defined for each programmable module using the Line Segment or Signal Span function (Algorithm 13) are listed below. Refer to *Appendix 2 – Worksheet 2*, or *Appendix 1 – Table 1: Item List*, for the Item addresses. In the table below, *x* in the PM Tag name is the programmable module number from 1 to 6.

Table 15: Line Segment Algorithm Configuration Items

PM Tag	Alg Tag	Type	Description
PMxK1	—	Number	Not used.
PMxl1@	I1@	Connection	Input 1 (I1)
PMxl2@	I2@	Connection	Input 2 (I2): (optional)*
PMxl3@	I3@	Connection	Input 3 (I3): (optional)* * When not connected, an input assumes a default value of 0.
PMxTYP	TYP CND1 CND2 CND3	2 Bytes Bits 5...1 Bits 13...6 Bit 14 Bit 15 Bit 16	Algorithm Options define the behaviour of the programmable module. Algorithm Number in binary code: 01101 (0D hex) = Algorithm 13. Not used. 1 = I1 included only in COMFORT. 1 = I2 included only in COMFORT. 1 = I3 included only in COMFORT.
PMxK2	X ₀	Number	Defines input value for first break point.
PMxK3	Y ₀	Number	Defines output value at first break point.
PMxK4	X ₁	Number	Defines input value for second break point.
PMxK5	Y ₁	Number	Defines output value at second break point.
PMxK6	—	Number	Not used.
PMxK7	—	Number	Not used.

Dynamic Parameters for Line Segment Algorithm

The parameters that are dynamically generated by programmable modules configured as a line segment algorithm are listed below:

Table 16: Line Segment Algorithm Dynamic Items

Item Tag	Item Address (Hex/Dec)	Description
OCM1	0A/10	Output of Programmable Module 1
OCM2	0B/11	Output of Programmable Module 2
OCM3	0C/12	Output of Programmable Module 3
OCM4	0D/13	Output of Programmable Module 4
OCM5	0E/14	Output of Programmable Module 5
OCM6	0F/15	Output of Programmable Module 6

**External
Analog Input
Configuration
(XAI1 to XAI6)**

The TC-9100 Universal Controller has six external analog inputs that may be set by a supervisory system through the N2 Bus serial interface. The numerical value of an external analog input can be used as an input to a programmable module (configured as a Control Module or as a Calculation Module), and can be read by a supervisory system. The value of an external analog input can also be used as the input to the Summer/Winter Compensation Module or the Low Limit (Anti-freeze) Module, where, for example, the value of the outdoor air temperature is set by the supervisory system and then used in the controller to determine the level of set point compensation due to a high or low outside temperature, or to force the controller into Low Limit mode when the outdoor air temperature is low.

**Configuration
Parameters**

There are no configuration parameters for external analog inputs.

**Dynamic
Parameters**

Table 17: External Analog Input Dynamic Items

Item Tag	Item Address (Hex/Dec)	Description
XAI1	16/22	Value of External Analog Input 1
XAI2	17/23	Value of External Analog Input 2
XAI3	18/24	Value of External Analog Input 3
XAI4	19/25	Value of External Analog Input 4
XAI5	1A/26	Value of External Analog Input 5
XAI6	1B/27	Value of External Analog Input 6

Note: For troubleshooting purposes using the Service Module, “reliability status” bits are available for XAI1 to XAI4 in Item XST, Diagnostic Status (Item Address 84 hex).

**Low Limit
(Anti-freeze)
Module
Configuration**

The TC-9100 Universal Controller has a low limit module with a numerical input connection, a set point parameter, and a low limit differential parameter. The output of the module is set to 1 when the value of the input goes below the set point, and returns to 0 when the value of the input goes above the set point plus the value of the low limit differential. The output may be read by a supervisory system at Item LSC, Bit 6 (AFM), and the output of a programmable module configured as a Controller Algorithm can be forced to 100% when a Low Limit condition exists. This module is normally used for low temperature protection (anti-freeze), where the input is connected to an analog input or external analog input measuring room temperature or outdoor air temperature, and controller modules controlling perimeter heating are enabled for Low Limit module override. The Low Limit override has the highest priority in a control module and will override all other overrides, including the OFF mode override. Refer to *Controller Algorithms 1 to 6 – General* under *Programmable Module Configuration* for further details.

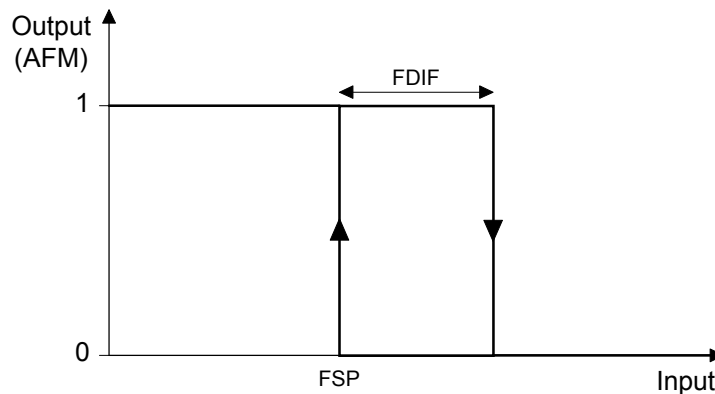

Figure 14: Low Limit Module Function

**Configuration
Parameters**

The configuration parameters to be defined for the low limit module are listed below. Refer to *Appendix 2 – Worksheet 3*, or *Appendix 1 – Table 1: Item List*, for the Item addresses.

Table 18: Low Limit (Anti-freeze) Module Configuration Items

Item Tag	Type	Description
FT@	Connection	Source of the input value for the low limit module.
FSP	Number	Set Point value of the low limit module.
FDIF	Number	Low Limit Differential

**Dynamic
Parameters**

The parameter that is dynamically generated by the controller from the configuration parameters is shown below:

Table 19: Low Limit (Anti-freeze) Module Dynamic Items

Item Tag	Item Address (Hex/Dec)	Description
AFM	26/38, Bit 6	Low Limit Module Output (Anti-freeze Mode)

Summer/Winter Compensation Module

The TC-9100 Universal Controller has a Summer/Winter Compensation module with a numerical input connection, summer and winter set point and authority slope parameters, and two outputs that may be read by a supervisory system. The first output (WAC) is active when the value of the input is below the winter set point, and the second output (SAC) is active when the value of the input is above the summer set point. The input is normally connected to an analog input or to an external analog input (XAI1 to XAI4) measuring the outdoor temperature. When one of the external analog inputs is connected, the output of the module will be set to 0 after a power failure and the module will not calculate a new output until the external analog input has received a new value from the supervisory system. XAI5 and XAI6 should not be used as inputs to this module. The winter authority slope may be positive or negative but the summer authority slope can only be positive. The function of the module is shown below:

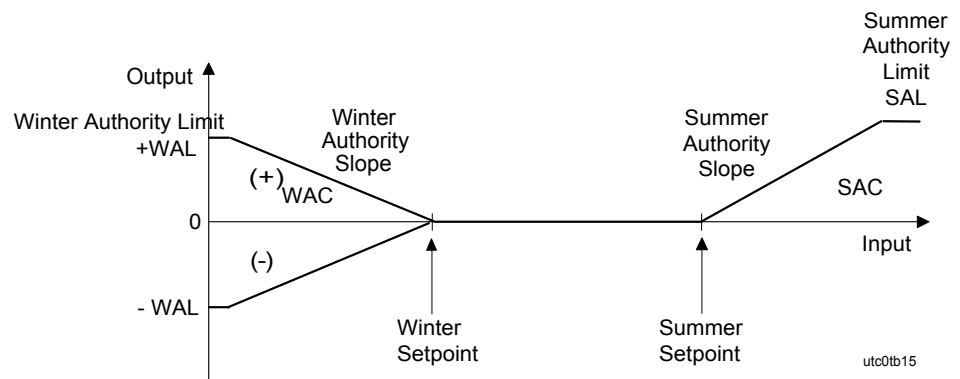

Figure 15: Summer/Winter Compensation Function

When the Summer or Winter Compensation is enabled in a programmable module configured as a Controller Algorithm, the working set point (WSP) of the module is adjusted by the value of SAC or WAC, respectively. Summer Compensation is normally enabled for cooling controllers and Winter Compensation is normally enabled for heating controllers. The maximum amount of compensation is limited by the parameters SAL and WAL.

Configuration Parameters

The configuration parameters to be defined for the summer/winter compensation module are listed below. Refer to *Appendix 2 – Worksheet 3*, or *Appendix 1 – Table 1: Item List*, for the Item addresses.

Table 20: Summer/Winter Compensation Configuration Items

Item Tag	Type	Description
OT@	Connection	Source of the input value for the module — normally the outdoor air temperature.
SPW	Number	Winter Set Point value.
SPS	Number	Summer Set Point value.
WA	Number	Winter Authority slope in degrees per degree of outdoor temperature below set point. Value may be positive or negative.
SA	Number	Summer Authority slope in degrees per degree of outdoor temperature above set point. Value can only be positive.
WAL	Number	Winter Authority Limit - limit of compensation in winter.
SAL	Number	Summer Authority Limit - limit of compensation in summer.

Dynamic Parameters

The parameters that are dynamically generated by the controller from the configuration parameters are listed below:

Table 21: Summer/Winter Compensation Dynamic Items

Item Tag	Item Address (Hex/Dec)	Description
WAC	1C/28	Winter Authority Compensation Value
SAC	1D/29	Summer Authority Compensation Value

Auto-dial Feature

When the TC-9100 Universal Controller is supervised by an N2 Dial Module (Order Code NU-NDM101-0), the N2 Dial Module will initiate a telephone dial-up connection to a central monitoring station (such as a Metasys NCM or Companion System) whenever it detects that the DIAL Bit (Item XST, Address 84 hex, Bit 5) is set. When the connection has been successfully completed, the central monitoring station will reset the DIAL Bit.

The DIAL Bit is set by the conditions shown in Table 22 below. Note that the bit is set by a **change-of-state** to the alarm or off-normal condition, and when it has been reset by the central monitoring system, it will not be set again until a different change-of-state occurs, or the same condition returns to normal **and** then changes again into the alarm or off-normal condition. The return to normal change does not set the DIAL Bit.

Table 22: Auto-dial Conditions

Condition	Description
AIH n = 1	Analog Input n High Alarm ($n=1-4$)
AIL n = 1	Analog Input n Low Alarm ($n=1-4$)
WIN = 1	Window Open
ALM = 1	General Alarm
AFM = 1	Low Limit (Anti-freeze) Mode Active

**Supervisory
Functions and
Configuration
Monitoring and
Control**

The TC-9100 Universal Controller may be monitored and controlled by a supervisory system via the RS-485 communications bus. In addition to the reading and writing of operating parameters, detailed in each of the sections on the configuration of inputs, outputs and programmable modules, the supervisory system may read and set the operating and control modes of the controller. These modes are described in the section *Modes of Operation* at the beginning of this manual.

In order to set the operating mode of the controller, the supervisory system must set the Supervisory System Active Refresh Bit on power-up, and afterwards once every hour, and the Supervisory Mode Control Bit or the Manual Operating Mode (MAN) Bit must be set to tell the controller to use the operating mode command from the supervisory system. When the manual operating mode is set, the controller always uses the operating mode given by the supervisory system, ignoring the Local Occupancy sensor and Alternate Occupancy mode commands. All supervisory system commands must be sent again after a power failure.

When neither the Supervisory Mode Control Bit nor the Manual Operating Mode Bit is set, the operating mode can be set by the TM-9180 Room Command Module. If a TM-9180 module is not connected, the controller will remain in Standalone mode.

Shutoff Mode

For consistency with the DR-9100 series of controllers, the TC-9100 Universal Controller will accept a Shutoff mode command from the supervisory system. The Shutoff mode in the TC-9100 controller is synonymous with the OFF mode, and a Shutoff mode command will override an operating mode command (COMFORT, STANDBY or NIGHT) and a Startup mode command.

Startup Mode

The Startup mode may be used to force the output of a programmable module configured as a controller algorithm to a maximum (100%) or minimum (0% or Low Limit value, whichever is lower) level during a startup phase of control.

The Startup mode command is sent from the supervisory system and is canceled when the absolute error (| Process Variable – Working Set Point |) in Programmable Module 1 is less than 5% of the range of the process variable.

To use the Startup mode, Programmable Module 1 must be configured as the main control module, and the range of the sensor connected to the process variable must be selected such that 5% of the range represents the control deviation which cancels the Startup mode. For example, if a sensor range of 0 - 40°C was chosen, and the control set point is 20°C in a heating controller, the Startup mode would be canceled at 18°C.

Hold Mode

Each programmable module may be set to Hold mode by the supervisory system. In Hold mode, the output of the module (OCMn) may be written (overridden) by the supervisory system. When the Hold mode is reset, the output is again calculated by the programmable module. The Metasys Network System and Companion System automatically set and reset the Hold modes when the outputs are adjusted and released. The Hold modes are not canceled when the supervisory system fails to update the Supervisory System Active Refresh Bit, but they are canceled by a power failure to the controller.

If the programmable module is configured as a heating/cooling controller (algorithms 3 to 6), both the heating (Loop 1) and cooling (Loop 2) controllers are put into Hold mode when either the heating (Loop 1) controller or the cooling (Loop 2) controller is set to Hold mode. For single output algorithms 3 and 4, only the output of Loop 1 may be modified, and the output of Loop 2 will follow automatically. For dual output algorithms 5 and 6, the outputs of loops 1 and 2 may be modified independently.

Computer Mode

Each programmable module configured as a controller algorithm may be set into Computer mode by the supervisory system. In Computer mode, the Working Set Point (WSP) of the module must be continuously set by the supervisory system. When the Computer mode is reset, the working set point is again calculated by the control algorithm. The Computer mode is canceled when the supervisory system fails to update the Supervisory System Active Refresh Bit, and is also canceled by a power failure to the controller.

If the programmable module is configured as a heating/cooling controller (algorithms 3-6), both the heating (Loop 1) and cooling (Loop 2) controllers are put into Computer mode when either the heating controller or the cooling controller is set to Computer mode.

Maintenance Indications

When any parameter is changed by a Service Module (SM-9100) connected to the controller, the Maintenance Started and Stopped bits are set. If a new configuration is downloaded into the controller from a Service Module, the Maintenance Started Bit is set at the beginning of the download, and the Maintenance Stopped Bit is set at the completion of the download. These bits may be read by the supervisory system to indicate that configuration or parameter changes have taken place. A special command is available to reset the Maintenance bits from the supervisory system.

**Digital Output
Override Control**

Each Digital Output may be controlled directly by the supervisory system by setting the corresponding Enable Bit. When the Enable Bit is set, the digital output will follow the status of the Control Command Bit and the output control module for the digital output no longer has control. It is recommended that the Digital Output Override Control feature is only used for digital outputs which are not used in the controller configuration, or to override outputs configured as on/off type outputs. To override digital outputs configured as PAT, DAT, 2-stage on/off, or 3-speed fan control type outputs, it is recommended to use the Hold mode on the control module that is connected to the output module.

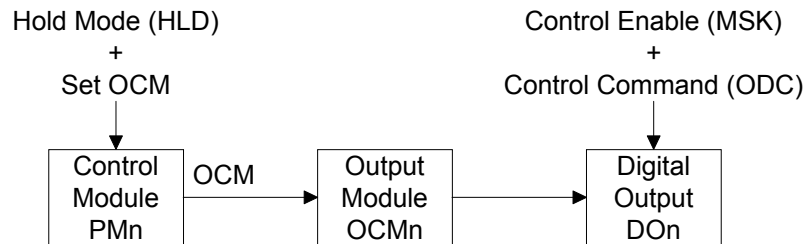

Figure 16: Overrides by Supervisory System

**Reverse Action
Command**

When neither of the digital inputs is configured as a Reverse Action type, the action of any programmable module configured as a Controller Algorithm may be reversed by a command from the supervisory system to the REVC Item (Address 87 hex, Bit 8). The Reverse Action status of the controller can be read at the REVL Item. Refer to *Programmable Module Configuration, Controller Algorithms 1 to 6 – General*.

Note: If one of the digital inputs *is* configured as a Reverse Action type, the controller will respond *only* to the digital input (i.e., the REVC command will be ignored), and the REVL Item will always show the status of the digital input.

**Configuration
Parameters**

There is only one configuration parameter for supervisory system functions, as follows:

Table 23: Supervisory Functions Configuration Items

Item Tag	Type	Description
TCS2 (85 hex) (133 dec)	2 Bytes Bit 4	Controller Options 2 0 = Alternate Mode Timing = 2 hours. 1 = Alternate Mode Timing = 1 hour.

**Dynamic
Parameters**

The parameters that are dynamically generated and received by the controller for supervisory functions are listed below. Refer to *Appendix 1, Table 1, Item List* for the Item addresses.

Table 24: Supervisory Functions Dynamic Items

Item Tag	Item Address (Hex/Dec)	Description
ROS	20/32 Bits 2,1 Bit 3 Bit 4 Bit 5	<p>TC-9100 Operating Status</p> <p>Mode Status</p> <p>00 = NIGHT Mode. 01 = STANDBY Mode. 10 = COMFORT Mode. 11 = OFF Mode.</p> <p>1 = Temporary Alternate Mode Active. 1 = Alternate Mode Active. 1 = Supervisory System Active (automatically resets to "0" 2 hours after last refresh command to Item SUP Bit 8).</p>
SUP MODC SOFF STUP MAN	25/37 Bits 2,1 Bit 3 Bit 4 Bit 5 Bit 6 Bit 7 Bit 8	<p>Supervisory Mode Control</p> <p>Operating Mode Command</p> <p>00 = NIGHT Mode. 01 = STANDBY Mode. 10 = COMFORT Mode. 11 = OFF Mode.</p> <p>1 = Shutoff Mode Command. 1 = Startup Mode Command. Not used. 1 = Supervisory Mode Control Command (set with every Operating Mode Command). 1 = Manual Operating Mode Command (Override Occupancy Sensor and Occupancy Button/Alternate Mode). Set to "1" every hour to maintain Supervisory System Active.</p>
HLD	23/35 Bit 1 Bit 2 Bit 3 Bit 4 Bit 5 Bit 6	<p>Programmable Module Hold</p> <p>1 = Programmable Module 1 in Hold. 1 = Programmable Module 2 in Hold. 1 = Programmable Module 3 in Hold. 1 = Programmable Module 4 in Hold. 1 = Programmable Module 5 in Hold. 1 = Programmable Module 6 in Hold.</p>
CMP	24/36 Bit 1 Bit 2 Bit 3 Bit 4 Bit 5 Bit 6	<p>Computer Module Control</p> <p>1 = Control Module 1 WSP Override. 1 = Control Module 2 WSP Override. 1 = Control Module 3 WSP Override. 1 = Control Module 4 WSP Override. 1 = Control Module 5 WSP Override. 1 = Control Module 6 WSP Override.</p>
LSC MNT	26/38 Bit 1 Bit 2	<p>Control and Status</p> <p>1 = Maintenance Started. 1 = Maintenance Stopped. (Service Module has changed parameter or configuration).</p>
Continued on next page...		

Item Tag (Cont.)	Item Address (Hex/Dec)	Description
MSK	21/33	Outputs – Supervisory Control Enable
DO3E	Bit 1	1 = Enable Digital Output 3 for Supervisory Control.
DO4E	Bit 2	1 = Enable Digital Output 4 for Supervisory Control.
DO5E	Bit 3	1 = Enable Digital Output 5 for Supervisory Control.
DO6E	Bit 4	1 = Enable Digital Output 6 for Supervisory Control.
DO7E	Bit 5	1 = Enable Digital Output 7 for Supervisory Control.
DO1E	Bit 6	1 = Enable Digital Output 1 for Supervisory Control.
DO2E	Bit 7	1 = Enable Digital Output 2 for Supervisory Control.
ODC	22/34	Outputs – Supervisory Control Command
DO3C	Bit 1	1 = Set Digital Output 3 On if DO3E = 1. 0 = Set Digital Output 3 Off if DO3E = 1.
DO4C	Bit 2	1 = Set Digital Output 4 On if DO4E = 1. 0 = Set Digital Output 4 Off if DO4E = 1.
DO5C	Bit 3	1 = Set Digital Output 5 On if DO5E = 1. 0 = Set Digital Output 5 Off if DO5E = 1.
DO6C	Bit 4	1 = Set Digital Output 6 On if DO6E = 1. 0 = Set Digital Output 6 Off if DO6E = 1.
DO7C	Bit 5	1 = Set Digital Output 7 On if DO7E = 1. 0 = Set Digital Output 7 Off if DO7E = 1.
DO1C	Bit 6	1 = Set Digital Output 1 On if DO1E = 1. 0 = Set Digital Output 1 Off if DO1E = 1.
DO2C	Bit 7	1 = Set Digital Output 2 On if DO2E = 1. 0 = Set Digital Output 2 Off if DO2E = 1.

Configuration for a TM-9180 Room Command Module

Certain configuration rules must be followed to enable the controller to operate correctly with the room command module. All features of the room command module are available, except for the viewing and setting of set points and biases for the operating modes of the controller, which are reserved for the TC-9102 controller only.

The room temperature process variable must be configured as AI1. The room command module will automatically write the value of the room temperature into AI1 (Item 01), unless Bit 3 of Item TCS2 (85 Hex / 133 Dec) is set to “1”, in which case a TS-9100 or **RS-1100** series sensor (with a 0-10V output) must be physically connected to the input terminals for AI1 (25, 50, 52).

The remote room set point must be configured as AI2. The room command module will automatically write the value of the room set point into AI2 (Item 02). The controller will ignore a remote set point device connected to the input terminal for AI2 (26, 50, 52) when the TM-9180 Room Command Module is connected.

If it is desired to display the outdoor temperature on the room command module, then the supervisory system must periodically write the value of the outdoor temperature in °C to External Analog Input 4 (XAI4 Item 19 Hex / 25 Decimal) and update the value after a power interruption.

The heating symbol on the room command module is displayed when the output of Programmable Module 1 is greater than 5%. Therefore, Programmable Module 1 must be configured as the main heating controller for the room.

The cooling symbol on the room command module is displayed when the output of Programmable Module 2 is greater than 5%. Therefore Programmable Module 2 must be configured as the main cooling controller for the room.

The window symbol on the room command module is displayed when either DI1 or DI2 is configured in Item TCS2 (85 Hex / 133 Decimal) for the Window Open logic mode and the window contact signals that the window is open.

The Configuration Index 1 (ALG Item 83 Hex / 131 Decimal) determines the range of the set point in the room command module and whether 3-speed fan speed override is available. Refer to Table 25 below.

The TM-9180 can only be used to set the operating mode of the controller when the operating mode is not being set by a supervisory system. A supervisory system always has priority over the TM-9180 module. No special configuration is required for setting the operating mode or for the use of the Time Scheduling feature, but a room command module with Programming mode must be ordered.

Note: When the TM-9180 Room Command Module is connected to the TC-9100 Universal Controller, the three jumpers (JP3) on the controller board must be set to the left positions.

Configuration Parameters

The configuration parameters TM-9180 Room Command Module are listed below.

Table 25: TM-9180 Configuration Items

Item Tag	Type	Description
TCS2 (85 hex) (133 dec)	2 Bytes Bit 3	AI1 not overridden by TM-9180. 0 = Room Temperature given by TM-9180 1 = Room Temperature sensor must be physically connected to AI1 input terminals.
ALG (83 hex) (131 dec)	2 Bytes	Configuration Index 1 0000 = Set point range 12 to 28°C (without 3-speed fan control) 0002 = Set point range 12 to 28°C with 3-speed fan control 0005 = Set point range +/- 3K (without 3-speed fan control) 0007 = Set point range +/- 3K with 3-speed fan control

Dynamic Parameters

There are a number of dynamic parameters generated by the controller which can be viewed on the SM-9100 for diagnostic purposes. They are not available for monitoring by supervisory systems from Johnson Controls. Refer to *Appendix 1 - Table 1: Item List*, Items 9D/157, A7/167, and A8/168 for details.

Installation

The TC-9100 Universal Controller is designed to be mounted close to the terminal unit equipment being controlled, within a Fan Coil Unit housing for example, or within an electrical control cabinet. The mounting location must be clean and dry, and not subject to extreme heat, cold, or electrical disturbances. The installation and electrical wiring must conform to local codes and should be carried out by authorized personnel only. Users should ensure that all Johnson Controls' products are used safely and without risk to health or property.

Mounting

For surface mounting, slide the two mounting brackets into the slots at opposite corners of the controller base behind the terminals. Fix to the surface using the 4-mm diameter self-tapping screws.

For DIN rail mounting, place the controller on the upper edge of the rail and press the controller firmly against the rail until the spring-loaded clip engages the lower edge of the rail. To remove the controller, insert a screw driver into the clip at the base of the controller and pull the clip downwards to release.

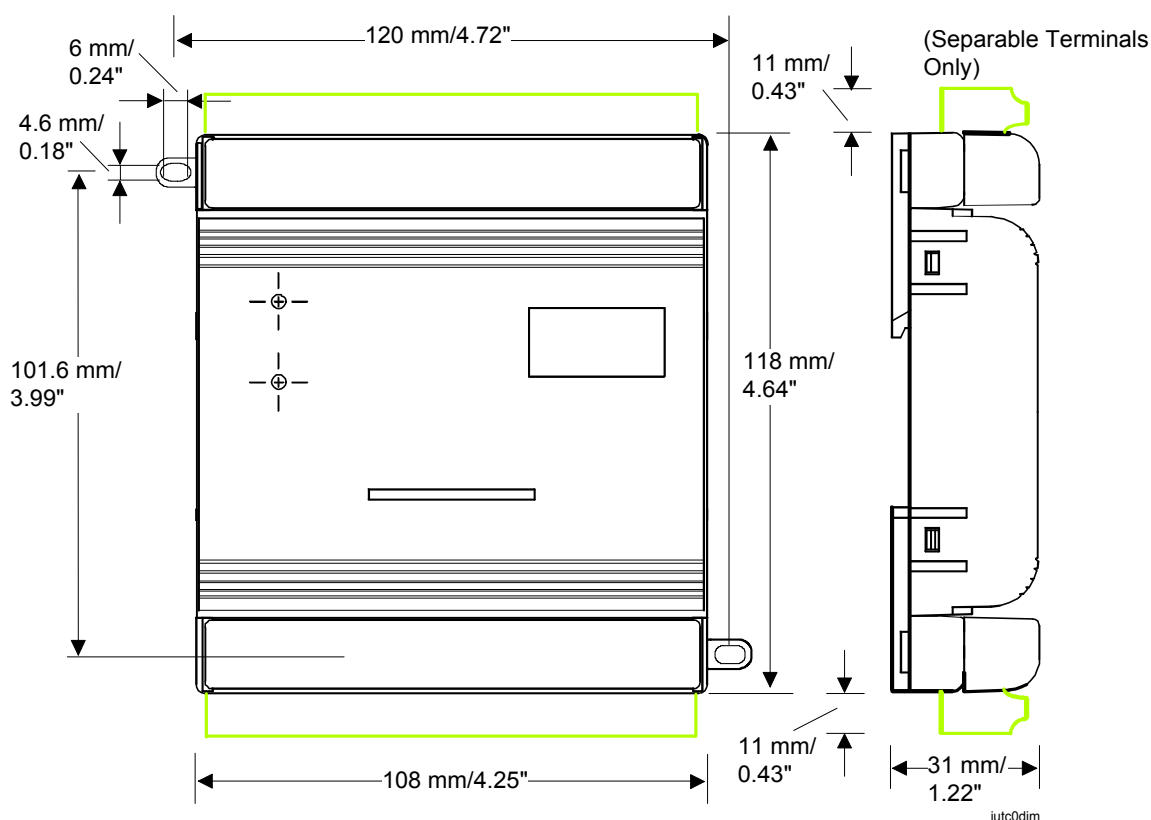

Figure 17: TC-9100 Controller Dimensions in mm

Note: A minimum of 25 mm of space is required above and below the controller for the removal of separable terminals.

Wiring

Before connecting or disconnecting any wires, ensure that all power supplies have been switched off and all wires are potential-free to prevent equipment damage and avoid electrical shock.

Terminations are made on the terminal blocks, at the top and bottom of the controller, which accept up to 1.5 mm² wires. Follow the wiring diagrams shown in figures 18 to 26.

When the TC-9100 model with separable terminal blocks is being wired, it is recommended that the removable parts of the blocks be unplugged before terminating the wires, and that they are not plugged in again until the wiring has been fully checked.

Separate **safety extra low voltage (SELV)** wiring from power line voltage wiring. A distinctive colour such as white or pink is recommended for low voltage wiring. Keep all cables as short as possible and tie in position. Do not run cables close to transformers or high frequency generating equipment.

The 24 V supply must be stable and not shared with other switched inductive loads. When multiple loads are connected to one transformer, wire each load from the transformer separately so that any possible disturbances from one load will have minimal effect on other loads.

Complete and verify all wiring connections before continuing with the installation procedure.

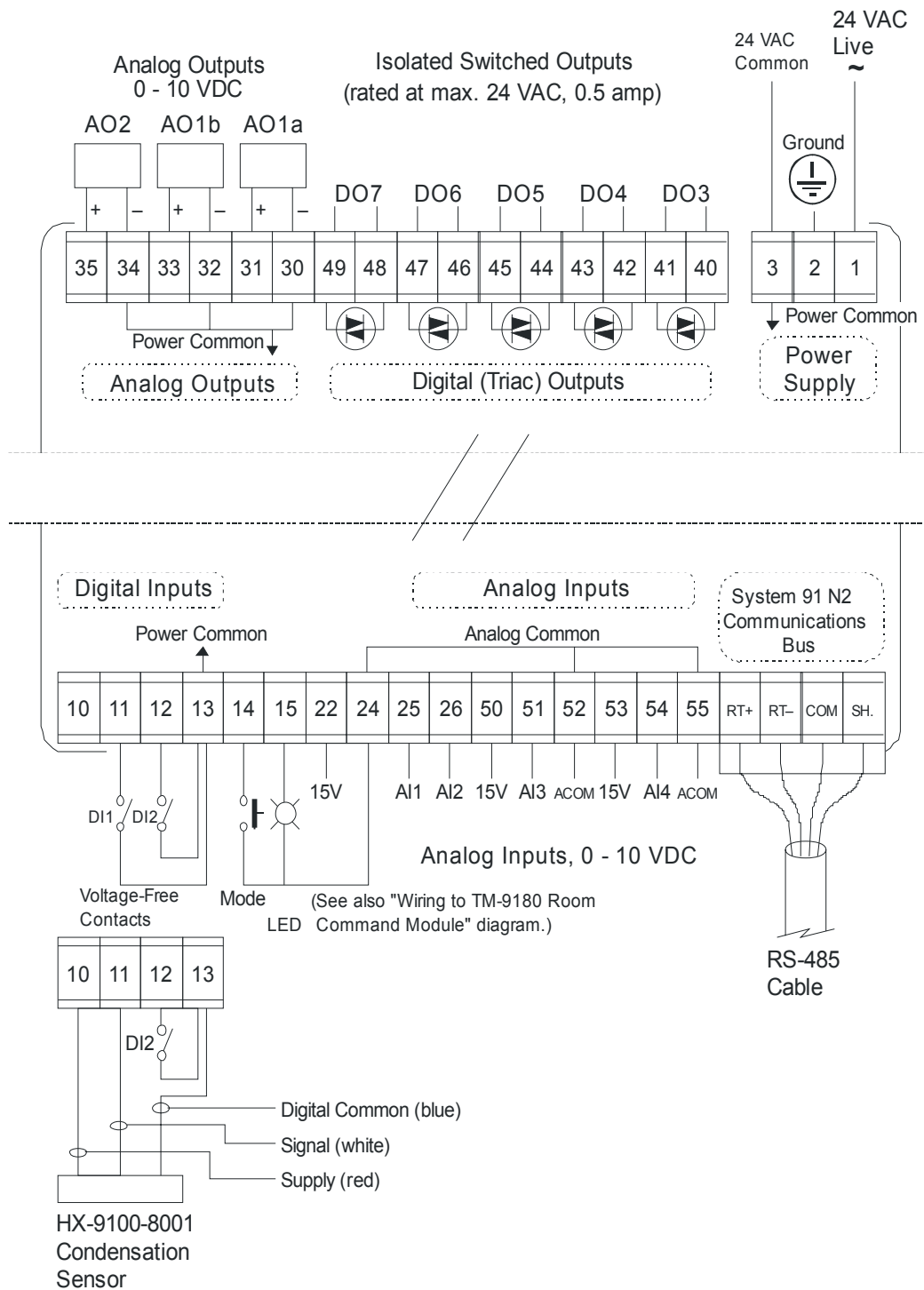

Figure 18: TC-9100-x000 (with Analog Outputs) Controller Wiring

- Notes:
1. The Digital (triac) Outputs are isolated from all other internal circuits.
 2. The Analog Outputs and Digital Inputs have the same “common” as the 24 VAC Power Supply.
 3. The Analog Input “common” is the same as the internal logic circuit common, but is isolated from the 24 VAC Power Common.
 4. The System 91 N2 Communications Bus is isolated from all other internal circuits.

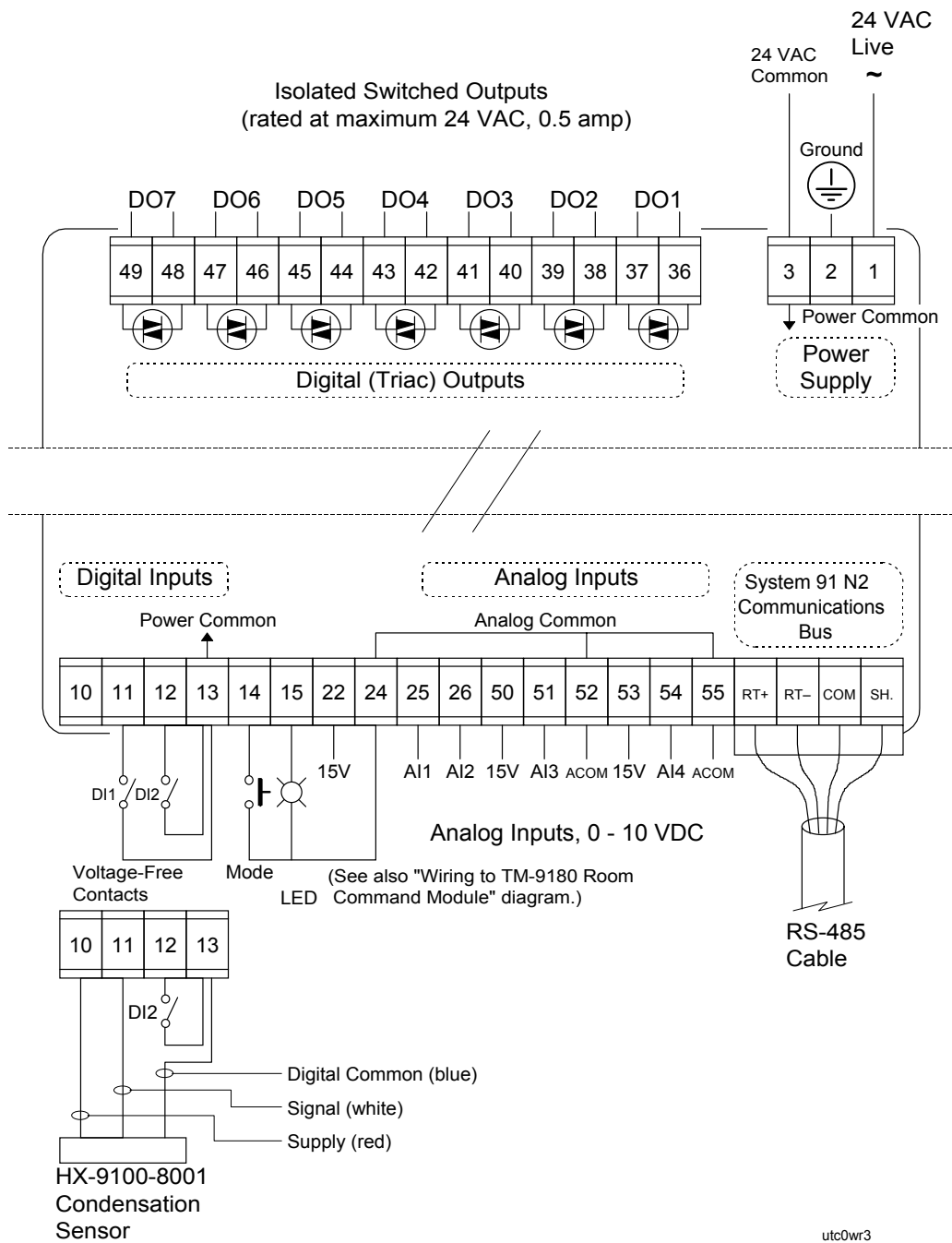

Figure 19: TC-9100-x001 (without Analog Outputs) Controller Wiring

- Notes:
1. The Digital (triac) Outputs are isolated from all other internal circuits.
 2. The Digital Inputs have the same “common” as the 24 VAC Power Supply.
 3. The Analog Input “common” is the same as the internal logic circuit common, but is isolated from the 24 VAC Power Common.
 4. The System 91 N2 Communications Bus is isolated from all other internal circuits.

(Old Figure 20 Deleted)

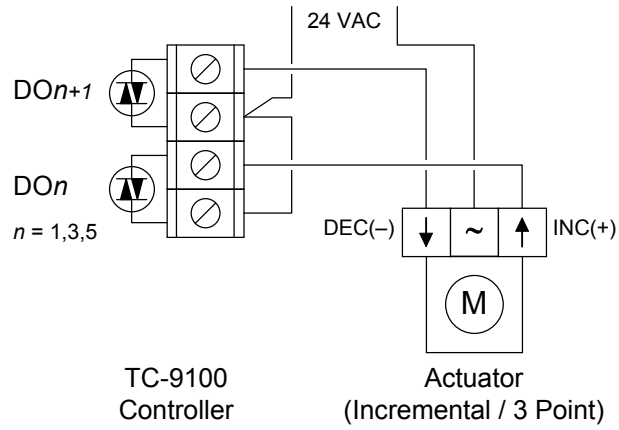

Figure 20: PAT Wiring

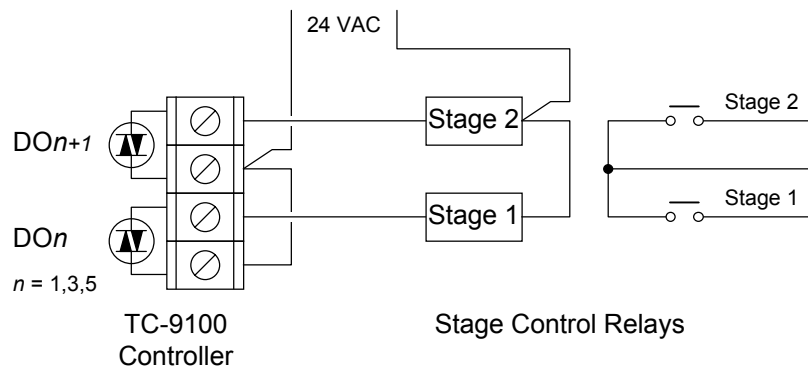

Figure 21: 2-Stage On/Off Wiring

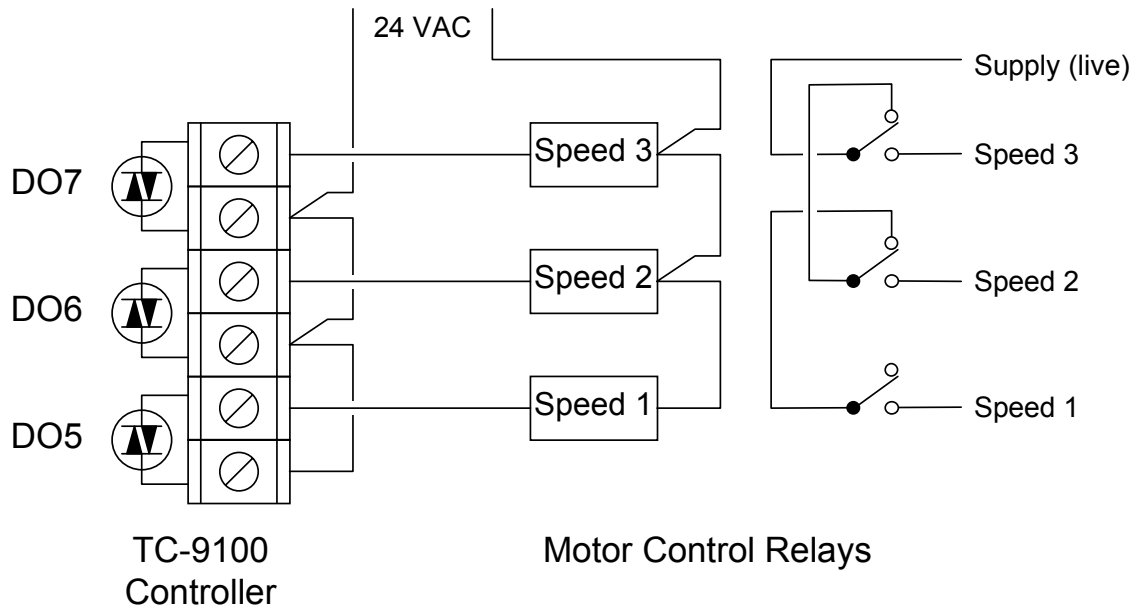

Figure 22: 3-Speed Fan Wiring

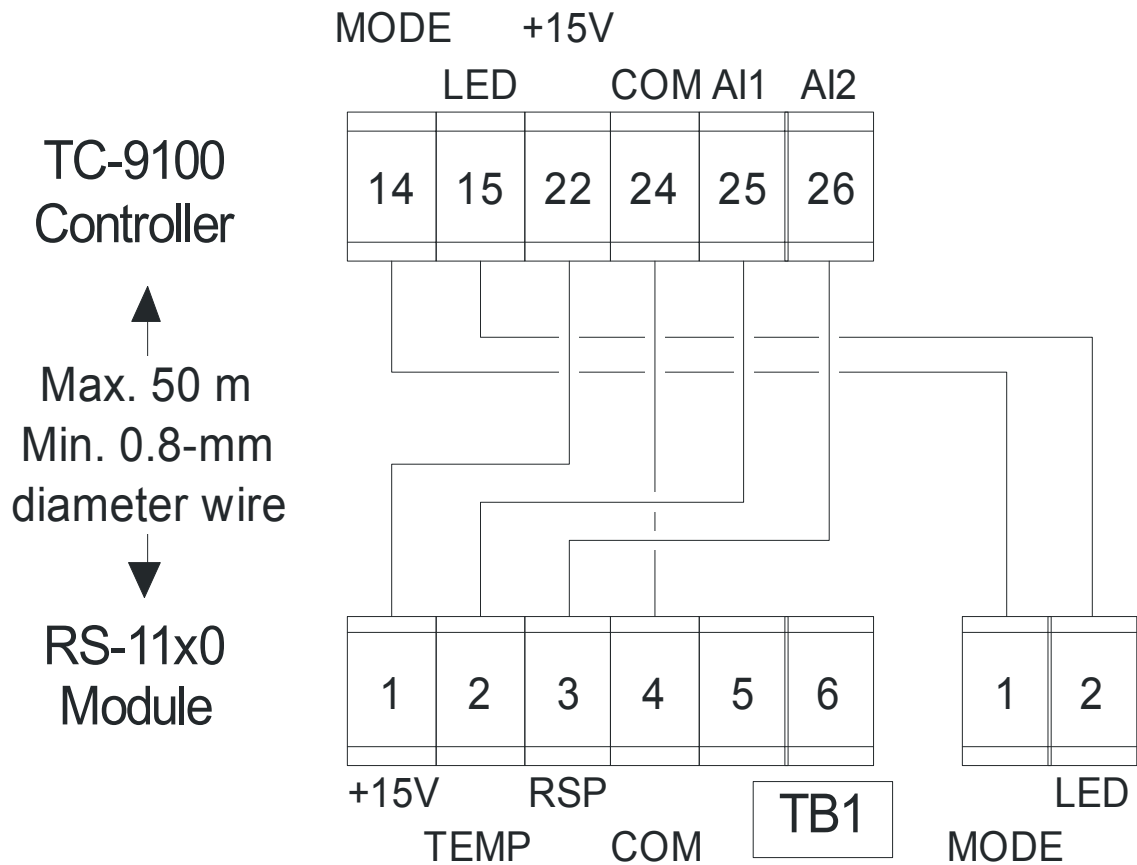

Figure 23: Wiring to RS-11x0 Module

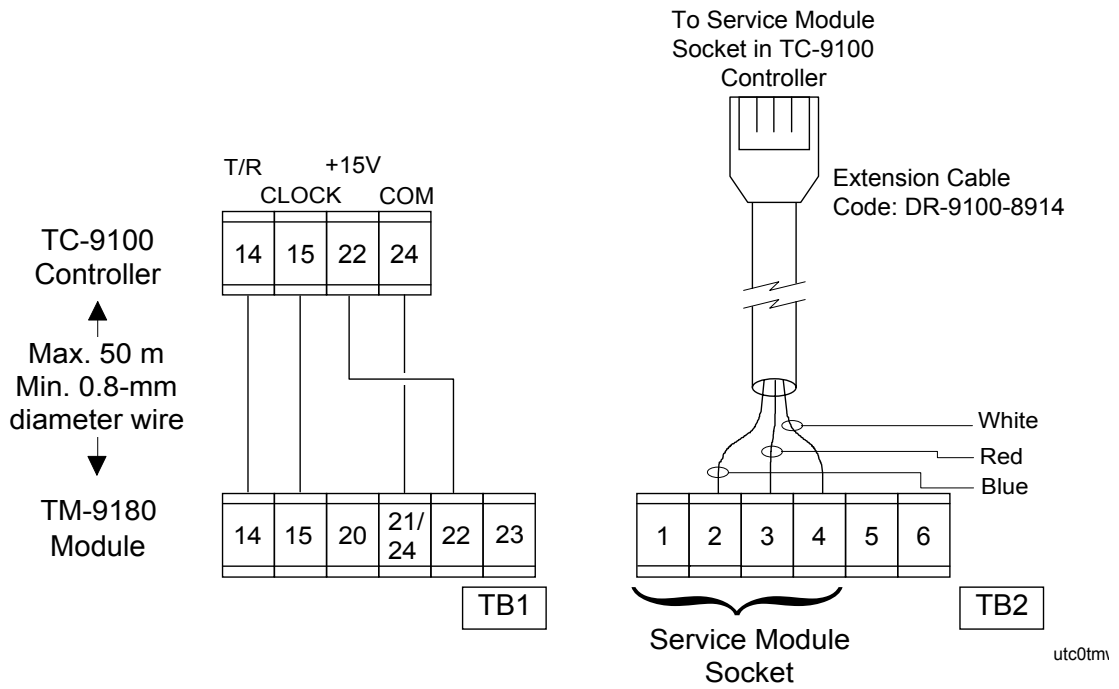

Figure 24: Wiring to TM-9180 Room Command Module

Note: Set JP3 to left position. See *Jumper and Switch Settings*.

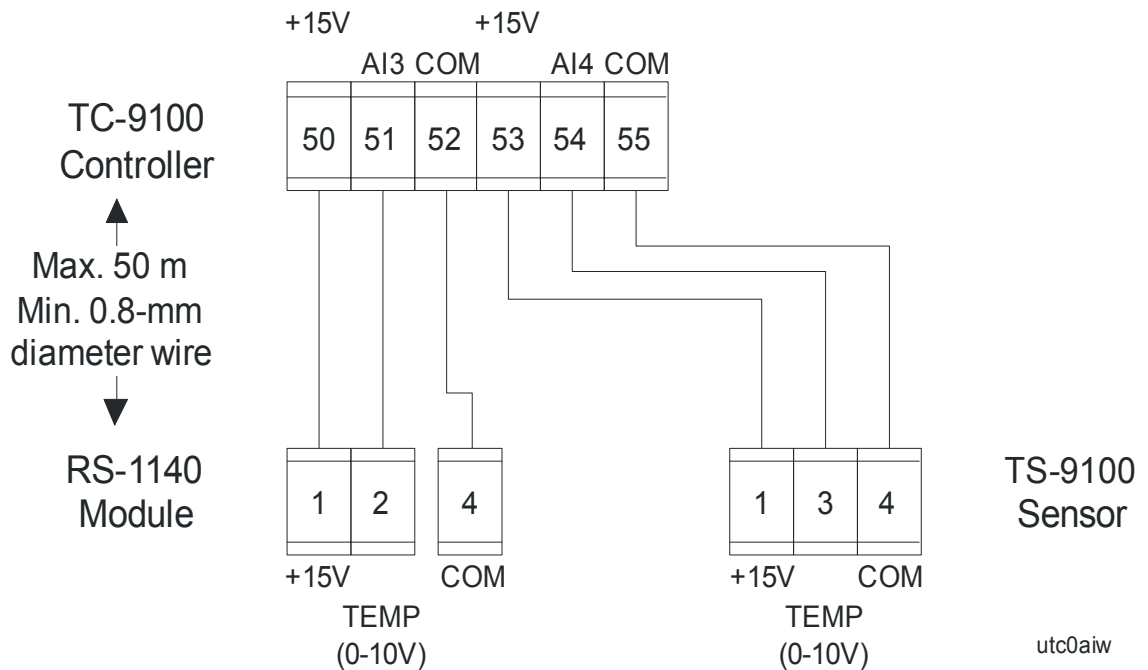

Figure 25: Wiring to Analog Inputs

Jumper and Switch Selections

To reach the jumpers and switches, open the controller by gripping the cover with thumb and finger on both sides above center and pull the cover off using the lower edge as a hinge. Replace the cover by resting the lower edge of the cover against the base and then pressing the cover firmly to engage all four retaining lugs.

Address Switches

If the controller is connected to a communications bus, a network address must be set. Refer to the project documentation for the correct address setting for the controller. Addresses 0 to 255 can be set on the address switches as follows:

The setting on the Address Switches is in binary format:

Switch Number	1	2	3	4	5	6	7	8
Decimal Equivalent	1	2	4	8	16	32	64	128

Example (Address 171):

Switch Number	1	2	3	4	5	6	7	8
Switch Position	ON	ON	OFF	ON	OFF	ON	OFF	ON
Decimal Equivalent: 171 =	1 +	2 +	0 +	8 +	0 +	32 +	0 +	128

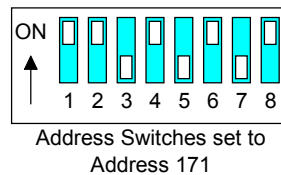

Jumpers

The jumpers on jumper block JP3 are used to select the type of room command module as follows:

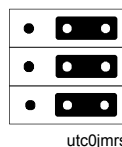

Jumpers are inserted to the right positions for the **RS-1100** series room module (factory default).

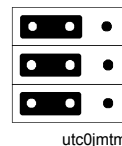

Jumpers are inserted to the left positions for the TM-9180 Room Command Module.

The jumpers on jumper block JP4 are used to select the types of analog outputs (only on models that have analog outputs), as follows:

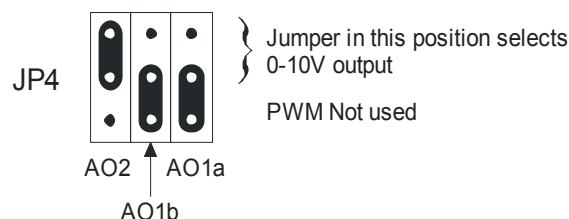

Figure 26: Jumper Settings for Analog Output Types

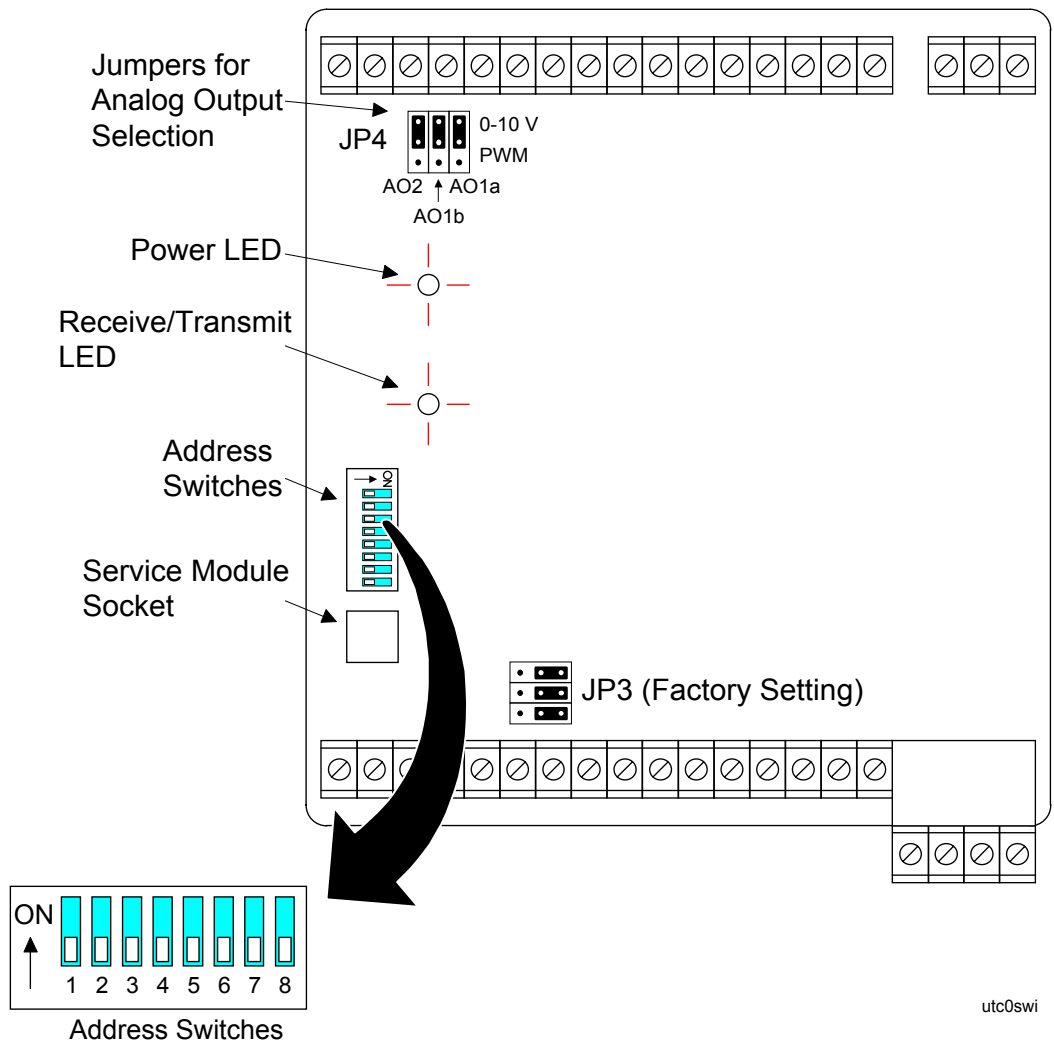

Figure 27: TC-9100 Controller Jumpers and Switches

Startup

When all jumpers and address switches have been set, and all connections have been made and verified, 24 VAC power may be applied. The Power LED should be lit. If the communications bus is active the R/T LED will flash. If the Power LED is not lit, check the 24 V supply.

Commissioning

The operation of the TC-9100 Universal Controller can be verified using the SM-9100 Service Module (or M9101 Software running on a PC). All dynamic parameters may be viewed, and all supervisory system functions can be executed using these configuration and commissioning tools.

For details of the SM-9100 operation, refer to the *SM-9100 User Guide (MN-9100-6101)*.

Specifications & Technical Data

Supply Voltage	24 VAC, ±15%, 50-60 Hz.										
Power Consumption	5 VA for controller only (not including power consumption of connected actuator devices).										
Ambient Operating Conditions	0° to 50°C 10 to 90% RH noncondensing										
Ambient Storage Conditions	-40° to 70°C 10 to 90% RH										
Terminations	Screw terminal blocks for 1 x 1.5 mm ² /14 AWG (maximum) cable. Separable terminal blocks are available as an option.										
Communication Interfaces	Optically isolated RS-485 interface for N2 Bus connection at 9600 baud. Service Module (SM-9100) interface at 600 baud: non-isolated synchronous bus. Room Command Module (TM-9180) interface at 600 baud: non-isolated synchronous bus.										
Controller Addressing	0-255 selectable on DIP switches (8).										
Inputs	<table border="0"> <tr> <td>Four analog inputs (AI1-AI4):</td> <td>0 to 10 VDC (controller input impedance > 100 KOhm).</td> </tr> <tr> <td>Supply for sensors:</td> <td>15 VDC, 20 mA.</td> </tr> <tr> <td>Two digital inputs (DI1, DI2):</td> <td>Volt-free contacts (closed contact resistance < 1 KOhm).</td> </tr> <tr> <td> Alternative (DI1 only):</td> <td>Condensation Sensor, Type HX-9100-8001.</td> </tr> <tr> <td>Occupancy button (Alternate mode):</td> <td>Volt-free momentary contact (use TM-9180 or RS-1150/RS-1160 room module).</td> </tr> </table>	Four analog inputs (AI1-AI4):	0 to 10 VDC (controller input impedance > 100 KOhm).	Supply for sensors:	15 VDC, 20 mA.	Two digital inputs (DI1, DI2):	Volt-free contacts (closed contact resistance < 1 KOhm).	Alternative (DI1 only):	Condensation Sensor, Type HX-9100-8001.	Occupancy button (Alternate mode):	Volt-free momentary contact (use TM-9180 or RS-1150/RS-1160 room module).
Four analog inputs (AI1-AI4):	0 to 10 VDC (controller input impedance > 100 KOhm).										
Supply for sensors:	15 VDC, 20 mA.										
Two digital inputs (DI1, DI2):	Volt-free contacts (closed contact resistance < 1 KOhm).										
Alternative (DI1 only):	Condensation Sensor, Type HX-9100-8001.										
Occupancy button (Alternate mode):	Volt-free momentary contact (use TM-9180 or RS-1150/RS-1160 room module).										
Continued on next page...											

Outputs (Cont.) **Model 1: TC-9100-x000**
 Two analog outputs: jumper selectable for either:
 0 to 10 VDC (10 mA maximum),
 or: PWM signal for Solenoid Valve Power Driver (**not used**).
 Five digital (triac) outputs: rated at 24 VAC (0.5 A maximum). Leakage current 1 mA maximum.
 Configurable as:
 PAT (Position Adjust Type – Incremental Control),
 DAT (Duration Adjust Type),
 2-stage on/off,
 3-speed fan control, or
 On/off output types.

Model 2: TC-9100-x001
 Seven digital (triac) outputs: rated at 24 VAC (0.5 A maximum). Leakage current 1 mA maximum.
 Configurable as:
 PAT (Position Adjust Type – Incremental Control),
 DAT (Duration Adjust Type),
 2-stage on/off,
 3-speed fan control, or
 On/off output types.

Models 1 and 2:
 Signal for Mode LED on TM-9180 or **RS-1150/RS-1160** room module.
 (Refer to *Software Configuration* section for output type configuration details.)

Mounting DIN rail or surface (two brackets supplied with controller).

Housing Material: ABS + polycarbonate, self-extinguishing VO UL94.
 Protection: IP30 (IEC529)

Dimensions (H x W x D) 118 mm* x 108 mm x 31 mm
 * 140 mm with separable terminals

Shipping Weight 0.3 kg

CE Compliance (Directive 89/336/EEC) **EN61000-6-3** (EN 50081-1), **EN61000-6-1** (EN 50082-1)

Ordering Codes

Table 26: TC-9100 Universal Controller Ordering Codes

Description	Model Code
TC-9100 Universal Controller with Analog Outputs	TC-9100-x000*
TC-9100 Universal Controller without Analog Outputs	TC-9100-x001*
* For controller with standard terminals, x = 0; with separable terminals, x = 1.	

Table 27: TC-9100 Controller Accessories Ordering Codes

Description	Model Code
Service Module	SM-9100-8101

Appendix 1: TC-9100 Item Descriptions and Tables

The operating parameters of the TC-9100 (constants, logic variables and analog values), can be accessed through the serial link for control or supervisory purposes. This appendix gives an overview of all of the parameters available in the controller. The parameters are called “Items.”

Item List Symbols

The column headings and symbols used in the Item List tables are described below:

Heading	Description and Symbols
Item	Item Index (or address) in hexadecimal and decimal code.
Type	Item Type, as follows: Number Floating point number. 1 Byte Unsigned 8-bit number used to represent logic states or integer numbers 0 to 0FFh (255 dec). 2 Bytes Unsigned 16-bit number used to represent logic states or unsigned integer numbers 0 to 0FFFFh (65,535 dec). Connection Internal soft connection to an analog Item, 0=not connected.
MEM	Item storage type in memory, using the following symbols: D Non-volatile Configuration Database (EEPROM).* VR Volatile Dynamic Database – initialized only at power-up reset. V Volatile Dynamic Database (RAM). F Firmware (ROM).
R/W	Read/Write Mode, using the following symbols: R Read-only Item. W Read/write Item. WP Read/write Item in protected EEPROM.*
Tag	Label for the Item, or for a bit within an Item.
PM Tag	Generic label for a Programmable Function Module Item, or for a bit within one of these Items.
Alg. Tag	Label for an Item, or a bit within an Item, in a Programmable Function Module, which is dependent upon the configured Algorithm.

***Note: Items in EEPROM may be written up to 10,000 times. These Items should only be changed very infrequently via the serial link in order to ensure that this limit is not exceeded during the lifetime of the controller.**

Floating Point Numbers

A floating point number in the TC-9100 controller consists of two bytes using the following bit encoding for the components of the number (in the communications buffer, the two bytes will be in the sequence least significant byte, then most significant byte):

15	14	13	12	11	10	9	8	7	6	5	4	3	2	1	0
E3	E2	E1	E0	S	M10	M9	M8	M7	M6	M5	M4	M3	M2	M1	M0

where: E3 to E0 = 4-bit exponent
 S = sign (1 = negative)
 M10 to M0 = 11-bit mantissa

- A number is normalized when the most significant bit is true (M10 = 1).
- The value of the n^{th} mantissa bit (n from 0 to 10) is:
 $2^{\text{exp} - (\text{EXPONENT} - n)}$.
- A number is zero when all bits of the mantissa are 0.
- The value of a number is:

$$\langle \text{NUMBER} \rangle = \langle \text{SIGN} \rangle \times \langle \text{MANTISSA} \rangle \times 2^{\text{exp} \langle \text{EXPONENT} \rangle}$$

Examples: 1 = 1400h or B001h
 -1 = 1C00h or B801h
 100 = 7640h or B064h

**Table 1:
Item List**

**General Dynamic
Parameters**

Item Hex	Item Dec	Type	MEM	R/W	Tag	Description
00	0	1 Byte	F	R	UNIT	Device Model: 06h
01	1	Number	V	R	AI1	Analog Input 1 Value
02	2	Number	V	R	AI2	Analog Input 2 Value
03	3	Number	V	R	AI3	Analog Input 3 Value
04	4	Number	V	R	AI4	Analog Input 4 Value
05	5					not used
06	6					not used
07	7					not used
08	8					not used
09	9	2 Bytes	V	R	ADC	Selected Analog Input ADC Counter (see Item 85h, TCS2)
0A	10	Number	VR	W	OCM1	Output Programmable Module 1
0B	11	Number	VR	W	OCM2	Output Programmable Module 2
0C	12	Number	VR	W	OCM3	Output Programmable Module 3
0D	13	Number	VR	W	OCM4	Output Programmable Module 4
0E	14	Number	VR	W	OCM5	Output Programmable Module 5
0F	15	Number	VR	W	OCM6	Output Programmable Module 6
10	16	Number	VR	W	WSP1	Working Set Point Control Module 1
11	17	Number	VR	W	WSP2	Working Set Point Control Module 2
12	18	Number	VR	W	WSP3	Working Set Point Control Module 3
13	19	Number	VR	W	WSP4	Working Set Point Control Module 4
14	20	Number	VR	W	WSP5	Working Set Point Control Module 5
15	21	Number	VR	W	WSP6	Working Set Point Control Module 6
16	22	Number	VR	W	XAI1	External Analog Input 1
17	23	Number	VR	W	XAI2	External Analog Input 2
18	24	Number	VR	W	XAI3	External Analog Input 3
19	25	Number	VR	W	XAI4	External Analog Input 4
1A	26	Number	VR	W	XAI5	External Analog Input 5
1B	27	Number	VR	W	XAI6	External Analog Input 6
1C	28	Number	VR	R	WAC	Winter Authority Compensation
1D	29	Number	VR	R	SAC	Summer Authority Compensation

Item Hex	Type Dec	MEM	R/W	Tag	Description	
1E	30	2 Bytes	V	R	ALR	Analog Input Alarm Status
		X1=1			AIH1	Analog Input 1 High Alarm
		X2=1			AIL1	Analog Input 1 Low Alarm
		X3=1			AIH2	Analog Input 2 High Alarm
		X4=1			AIL2	Analog Input 2 Low Alarm
		X5=1			AIH3	Analog Input 3 High Alarm
		X6=1			AIL3	Analog Input 3 Low Alarm
		X7=1			AIH4	Analog Input 4 High Alarm
		X8=1			AIL4	Analog Input 4 Low Alarm
		X16...X9				not used
1F	31	1 Byte	V	R	LOS	Logic Output Status
		X1=1			DO3	Digital Output 3 On
		X2=1			DO4	Digital Output 4 On
		X3=1			DO5	Digital Output 5 On
		X4=1			DO6	Digital Output 6 On
		X5=1			DO7	Digital Output 7 On
		X6=1			DO1	Digital Output 1 On
		X7=1			DO2	Digital Output 2 On
		X8				not used
20	32	1 Byte	V	R	ROS	TC-9100 Operating Status
		X2 X1			MODS	Mode Status
		=00				NIGHT Mode
		=01				STANDBY Mode
		=10				COMFORT Mode
		=11				OFF Mode
		X3=1			MODT	Temporary Mode
		X4=1			ALT	Alternate Mode
		X5=1				Supervisory System Active
		X6=1			WIN	Window Open
		X7=1			OCC	Occupancy
		X8=1			AIRQ	Air Quality/Override
		X8=1			AIRQ	Air Quality/Override

Item	Type	MEM	R/W	Tag	Description	
Hex	Dec					
21	33	1 Byte	VR	W	MSK	Outputs - Supervisory Control Enable
		X1=1			DO3E	Enable Digital Output 3
		X2=1			DO4E	Enable Digital Output 4
		X3=1			DO5E	Enable Digital Output 5
		X4=1			DO6E	Enable Digital Output 6
		X5=1			DO7E	Enable Digital Output 7
		X6=1			DO1E	Enable Digital Output 1
		X7=1			DO2E	Enable Digital Output 2
		X8				not used
22	34	1 Byte	VR	W	ODC	Outputs - Supervisory Control Command
		X1=1			DO3C	Set Digital Output 3 On
		X2=1			DO4C	Set Digital Output 4 On
		X3=1			DO5C	Set Digital Output 5 On
		X4=1			DO6C	Set Digital Output 6 On
		X5=1			DO7C	Set Digital Output 7 On
		X6=1			DO1C	Set Digital Output 1 On
		X7=1			DO2C	Set Digital Output 2 On
		X8				not used
23	35	1 Byte	VR	W	HLD	Programmable Module Hold
		X1=1				Programmable Module 1 Hold
		X2=1				Programmable Module 2 Hold
		X3=1				Programmable Module 3 Hold
		X4=1				Programmable Module 4 Hold
		X5=1				Programmable Module 5 Hold
		X6=1				Programmable Module 6 Hold
		X8,X7				not used
24	36	1 Byte	VR	W	CMP	Computer Mode Control
		X1=1				Control Module 1 WSP Override
		X2=1				Control Module 2 WSP Override
		X3=1				Control Module 3 WSP Override
		X4=1				Control Module 4 WSP Override
		X5=1				Control Module 5 WSP Override
		X6=1				Control Module 6 WSP Override
		X8,X7				not used

Item Hex	Type Dec	MEM	R/W	Tag	Description	
25	37	1 Byte	VR	W	SUP	Supervisory Mode Control
		X2 X1			MODC	Operating Mode Command
		=00				NIGHT Mode
		=01				STANDBY Mode
		=10				COMFORT Mode
		=11				OFF Mode
		X3=1			SOFF	Shutoff Mode Command
		X4=1			STUP	Startup Mode Command
		X5				not used
		X6=1				Supervisory Mode Control
		X7=1			MAN	Manual Operating Mode Command
		X8=1				Supervisory System Active Refresh
26	38	1 Byte	VR	R	LSC	Control & Status
		X1=1		R	MNT	Maintenance Started
		X2=1		R		Maintenance Stopped
		X3=1		R	REVL	Reverse Action Active
		X4=1		R	L1A	Control Module 1 Active
		X5=1		R	ALM	General Alarm
		X6=1		R	AFM	Low Limit (Anti-freeze) Mode Active
		X7=1		R	FOV	3-Speed Fan Override Active
		X8=1		R	L3A	Control Module 3 Active

**Programmable
Module
Configuration
Parameters**

(See *Table 2: Programmable Module Algorithms*, in this appendix for more detailed information.)

Item	Type	MEM	R/W	Tag	Description
Hex	Dec				
<i>Programmable Module 1</i>					
27	39	Number	D	W	PM1K1 Constant K1
28	40	Connection	D	WP	PM1I1@ Input Connection I1
29	41	Connection	D	WP	PM1I2@ Input Connection I2
2A	42	Connection	D	WP	PM1I3@ Input Connection I3
2B	43	2 Bytes	D	WP	PM1TY Options
				P	
2C	44	Number	D	WP	PM1K2 Constant K2
2D	45	Number	D	WP	PM1K3 Constant K3
2E	46	Number	D	WP	PM1K4 Constant K4
2F	47	Number	D	WP	PM1K5 Constant K5
30	48	Number	D	WP	PM1K6 Constant K6
31	49	Number	D	WP	PM1K7 Constant K7
<i>Programmable Module 2</i>					
32	50	Number	D	W	PM2K1 Constant K1
33	51	Connection	D	WP	PM2I1@ Input Connection I1
34	52	Connection	D	WP	PM2I2@ Input Connection I2
35	53	Connection	D	WP	PM2I3@ Input Connection I3
36	54	2 Bytes	D	WP	PM2TY Options
				P	
37	55	Number	D	WP	PM2K2 Constant K2
38	56	Number	D	WP	PM2K3 Constant K3
39	57	Number	D	WP	PM2K4 Constant K4
3A	58	Number	D	WP	PM2K5 Constant K5
3B	59	Number	D	WP	PM2K6 Constant K6
3C	60	Number	D	WP	PM2K7 Constant K7
<i>Programmable Module 3</i>					
3D	61	Number	D	W	PM3K1 Constant K1
3E	62	Connection	D	WP	PM3I1@ Input Connection I1
3F	63	Connection	D	WP	PM3I2@ Input Connection I2
40	64	Connection	D	WP	PM3I3@ Input Connection I3
41	65	2 Bytes	D	WP	PM3TY Options
				P	
42	66	Number	D	WP	PM3K2 Constant K2
43	67	Number	D	WP	PM3K3 Constant K3
44	68	Number	D	WP	PM3K4 Constant K4
45	69	Number	D	WP	PM3K5 Constant K5
46	70	Number	D	WP	PM3K6 Constant K6
47	71	Number	D	WP	PM3K7 Constant K7

Item Hex	Type Dec	MEM	R/W	Tag	Description
Programmable Module 4					
48	72	Number	D	W	PM4K1 Constant K1
49	73	Connection	D	WP	PM4I1@ Input Connection I1
4A	74	Connection	D	WP	PM4I2@ Input Connection I2
4B	75	Connection	D	WP	PM4I3@ Input Connection I3
4C	76	2 Bytes	D	WP	PM4TY P Options
4D	77	Number	D	WP	PM4K2 Constant K2
4E	78	Number	D	WP	PM4K3 Constant K3
4F	79	Number	D	WP	PM4K4 Constant K4
50	80	Number	D	WP	PM4K5 Constant K5
51	81	Number	D	WP	PM4K6 Constant K6
52	82	Number	D	WP	PM4K7 Constant K7
Programmable Module 5					
53	83	Number	D	W	PM5K1 Constant K1
54	84	Connection	D	WP	PM5I1@ Input Connection I1
55	85	Connection	D	WP	PM5I2@ Input Connection I2
56	86	Connection	D	WP	PM5I3@ Input Connection I3
57	87	2 Bytes	D	WP	PM5TY P Options
58	88	Number	D	WP	PM5K2 Constant K2
59	89	Number	D	WP	PM5K3 Constant K3
5A	90	Number	D	WP	PM5K4 Constant K4
5B	91	Number	D	WP	PM5K5 Constant K5
5C	92	Number	D	WP	PM5K6 Constant K6
5D	93	Number	D	WP	PM5K7 Constant K7
Programmable Module 6					
5E	94	Number	D	W	PM6K1 Constant K1
5F	95	Connection	D	WP	PM6I1@ Input Connection I1
60	96	Connection	D	WP	PM6I2@ Input Connection I2
61	97	Connection	D	WP	PM6I3@ Input Connection I3
62	98	2 Bytes	D	WP	PM6TY P Options
63	99	Number	D	WP	PM6K2 Constant K2
64	100	Number	D	WP	PM6K3 Constant K3
65	101	Number	D	WP	PM6K4 Constant K4
66	102	Number	D	WP	PM6K5 Constant K5
67	103	Number	D	WP	PM6K6 Constant K6
68	104	Number	D	WP	PM6K7 Constant K7

Input/Output Configuration Parameters

Item Hex	Type Dec	MEM	R/W	Tag	Description	
69	105	2 Bytes	F	R	VER	Firmware Version (binary code) 0001 = Version 2 0002 = Version 3 0003 = Version 4
6A	106					not used
6B	107					not used
6C	108	Number	D	WP	HIA1	High Alarm Value AI1
6D	109	Number	D	WP	LOA1	Low Alarm Value AI1
6E	110	Number	D	WP	HIA2	High Alarm Value AI2
6F	111	Number	D	WP	LOA2	Low Alarm Value AI2
70	112	Number	D	WP	HIA3	High Alarm Value AI3
71	113	Number	D	WP	LOA3	Low Alarm Value AI3
72	114	Number	D	WP	HIA4	High Alarm Value AI4
73	115	Number	D	WP	LOA4	Low Alarm Value AI4
74	116	1 Byte X5...X1 X8...X6 =000 =001 =010 =011 =100 =101 =110	D	WP	OCN1	Output 1 Configuration Source of Module in binary code (Numeric Items 0A to 0F, e.g., 0A = 01010) Output Type output not used output for solenoids (PWM) (not used) 0 to 10V Analog Output On/Off Output DAT Output PAT Output (also uses Output 2) 2-Stage On/Off (also uses Output 2)
75	117	Number	D	WP	OCO1	PAT/DAT Timing or Load Rating for Output Module 1
76	118	1 Byte X5...X1 X8...X6 =000 =001 =010 =011	D	WP	OCN2	Output 2 Configuration Source of Module in binary code (Numeric Items 0A to 0F, e.g., 0A = 01010) Output Type output not used (or used with Output 1) output for solenoids (PWM) (not used) 0 to 10V Analog Output On/Off Output
77	119	Number	D	WP	OCO2	PAT Dead Band or 2-Stage Differential for Output 1

Item Hex	Type Dec	MEM	R/W	Tag	Description	
78	120	1 Byte X5...X1	D	WP	OCN3	Output 3 Configuration Source of Module in binary code (Numeric Items 0A to 0F, e.g., 0A = 01010) Output Type =000 output not used =011 On/Off Output =100 DAT Output =101 PAT Output (also uses Output 4) =110 2-Stage On/Off (also uses Output 4)
79	121	Number	D	WP	OCO3	PAT/DAT Timing or Load Rating for Output Module 3
7A	122	1 Byte X5...X1	D	WP	OCN4	Output 4 Configuration Source of Module in binary code (Numeric Items 0A to 0F, e.g., 0A = 01010) Output Type =000 output not used (or used with Output 3) =011 On/Off Output
7B	123	Number	D	WP	OCO4	PAT Dead Band or 2-Stage Differential for Output 3
7C	124	1 Byte X5...X1	D	WP	OCN5	Output 5 Configuration Source of Module in binary code (Numeric Items 0A to 0F, e.g., 0A = 01010) Output Type =000 output not used =011 On/Off Output =100 DAT Output =101 PAT Output (also uses Output 6) =110 2-Stage On/Off (also uses Output 6) =111 3-Speed Fan Control (also uses Outputs 6 and 7)
7D	125	Number	D	WP	OCO5	PAT/DAT Timing, Load Rating for Output Module 5, or Fan Speed Break Point 1

Item Hex	Type Dec	MEM	R/W	Tag	Description	
7E	126	1 Byte X5...X1	D	WP	OCN6	Output 6 Configuration Source of Module in binary code (Numeric Items 0A to 0F, e.g. 0A = 01010), or Source of 3-speed fan override (Numeric Items 01 to 04, e.g. 03 = 00011) Output Type =000 output not used (or used with Output 5) =011 On/Off Output
7F	127	Number	D	WP	OCO6	PAT Dead Band, 2-Stage Differential for Output 5, or Fan Speed Break Point 2
80	128	1 Byte X5...X1 X8...X6 =000	D	WP	OCN7	Output 7 Configuration Fan Speed Differential in binary code (1...31%, e.g., 10%= 01010) Output Type output not used (or used with Output 5)
81	129	Number	D	WP	OCO7	Fan Speed Break Point 3

**General
Configuration
Parameters**

Item		Type	MEM	R/W	Tag	Description
Hex	Dec					
82	130					not used
83	131	2 Bytes	D	WP	ALG	Configuration Index 1
84	132	2 Bytes	VR	W	XST	Diagnostic Status
		X4...X1				not used
		X5=1		RC*	DIAL	Dial Request Status
		X8...X6				not used
		X9=1		R		XAI1 Unreliable (no external write over the N2 Bus or Service Module since power up)
		X10=1		R		XAI2 Unreliable (no external write over the N2 Bus or Service Module since power up)
		X11=1		R		XAI3 Unreliable (no external write over the N2 Bus or Service Module since power up)
		X12=1		R		XAI4 Unreliable (no external write over the N2 Bus or Service Module since power up)
		X13=1		R		EEPROM Not Protected (jumper inserted)
		X14=1		RC*	RST	Microprocessor Reset Cycle Indication
		X16 X15				Type of Reset
		=00		R		Power Up Reset
		=01		R		External Reset
		=10		R		Oscillator Failure Reset
		=11		R		Watchdog Reset

*Note: Although the bits of XST are read-only, data can be written to the XST Item. When data is written to XST (no matter what value), the two bits marked RC are always reset to zero (cleared).

Item	Type	MEM	R/W	Tag	Description	
Hex	Dec					
85	133	2 Bytes	D	WP	TCS2	Controller Options 2
		X2 X1				ADC Selection
		=00				Select AI1
		=01				Select AI2
		=10				Select AI3
		=11				Select AI4
		X3=1				AI1 not overridden by TM-9180
		X4=0				Alternate Mode Timing = 2 Hours
		X4=1				Alternate Mode Timing = 1 Hour
		X5=0				not used (Must be set to 0)
		X6=0				0=50 Hz Power Line
		X6=1				1=60 Hz Power Line
		X7=0				not used (Must be set to 0)
		X8=1				Digital Output 7 is On if Mode is COMFORT
		X11...X9				Digital Input 1 Logic Mode
		=000				input not used
		=001				Window Open
		=010				Occupancy Sensor
		=011				Air Quality Sensor/Override
		=100				Reverse Action
		=101				General Alarm
		X12=0				Open contact on Input 1 sets mode
		X12=1				Closed contact on Input 1 sets mode
		X15...X13				Digital Input 2 Logic Mode
		=000				input not used
		=001				Window Open
		=010				Occupancy Sensor
		=011				Air Quality Sensor/Override
		=100				Reverse Action
		=101				General Alarm
		X16=0				Open contact on Input 2 sets mode
		X16=1				Closed contact on Input 2 sets mode
86	134					not used
87	135	1 Byte	D	W	TCS1	Controller Options 1
		X7...X1				not used
		X8=1			REVC	Reverse Action Command
88	136					not used

Item	Type	MEM	R/W	Tag	Description	
Hex	Dec					
89	137	Number	D	WP	HRI1	High Range AI1
8A	138	Number	D	WP	LRI1	Low Range AI1
8B	139	Number	D	WP	FTC1	Filter Constant AI1
8C	140	Number	D	WP	OFS1	Offset Value AI1
8D	141	1 Byte	D	WP	IOP1	Analog Input 1 Options
		X3...X1				not used
		X4=0				Input Type: set to 0 (= 0-10V)
		X7...X5				Input Mode
		=000				Linear Range (0-10V input)
		=001				not used
		=010				Square Root (0-10V input)
		=011				20% zero suppression (2-10V input)
		X8				not used
8E	142	Number	D	WP	HRI2	High Range AI2
8F	143	Number	D	WP	LRI2	Low Range AI2
90	144	Number	D	WP	FTC2	Filter Constant AI2
91	145	Number	D	WP	OFS2	Offset Value AI2
92	146	1 Byte	D	WP	IOP2	Analog Input 2 Options (see IOP1)
93	147	Number	D	WP	HRI3	High Range AI3
94	148	Number	D	WP	LRI3	Low Range AI3
95	149	Number	D	WP	FTC3	Filter Constant AI3
96	150	Number	D	WP	OFS3	Offset Value AI3
97	151	1 Byte	D	WP	IOP3	Analog Input 3 Options (see IOP1)
98	152	Number	D	WP	HRI4	High Range AI4
99	153	Number	D	WP	LRI4	Low Range AI4
9A	154	Number	D	WP	FTC4	Filter Constant AI4
9B	155	Number	D	WP	OFS4	Offset Value AI4
9C	156	1 Byte	D	WP	IOP4	Analog Input 4 Options (see IOP1)
9D	157	1 Byte	VR	R	OS	TM-9180 Mode Control
		X2 X1				Requested Operating Mode
		=00				NIGHT Mode
		=01				STANDBY Mode
		=10				COMFORT Mode
		=11				OFF Mode
		X3				not used
		X4				not used
		X5				Alternate Mode Toggle
		X6				not used
		X7=1				Manual Override
		X8=1				TM-9180 Active
9E	158	2 Bytes	VR	W	TIME	TM-9180 Clock Synchronization

Item Hex	Type Dec	MEM	R/W	Tag	Description
Summer/Winter Compensation Module					
9F	159	Connection	D	WP OT@	Outdoor Temperature
A0	160	Number	D	W SPW	Winter Set Point
A1	161	Number	D	W SPS	Summer Set Point
A2	162	Number	D	W WA	Winter Authority Slope
A3	163	Number	D	W SA	Summer Authority Slope
Low Limit Module					
A4	164	Connection	D	WP FT@	Low Limit (Anti-freeze) Temperature Connection
A5	165	Number	D	W FSP	Low Limit (Anti-freeze) Set Point
A6	166	Number	D	WP FDIF	Low Limit (Anti-freeze) Differential
A7	167	2 Bytes	VR	R	LOO Local Output Override Status
		X2 X1			FANS 3-Speed Fan Status
		=00			OFF
		=01			Speed 1 (Low)
		=10			Speed 2 (Medium)
		=11			Speed 3 (High)
		X3			not used
		X4=1		FOS	Fan Override by Hardware Input
		X6 X5		FANT	TM-9180 Fan Override Status
		=00			OFF
		=01			Speed 1 (Low)
		=10			Speed 2 (Medium)
		=11			Speed 3 (High)
		X7			internal use
		X8=1		FOR	Fan Override by TM-9180
		X9=1		AI01	AI1 Override by TM-9180
		X10=1		AI02	AI2 Override by TM-9180
		X11=1		AI03	AI3 Override by TM-9180
		X12=1		AI04	AI4 Override by TM-9180
		X16...X13			not used

Item Hex	Type Dec	MEM	R/W	Tag	Description	
A8	168	2 Bytes	VR	R	CLACT	Control Loop Activity
		X1=1				PM1 Heating
		X2=1				PM2 Heating
		X3=1				PM3 Heating
		X4=1				PM4 Heating
		X5=1				PM5 Heating
		X6=1				PM6 Heating
		X7				not used
		X8				not used
		X9=1				PM1 Active
		X10=1				PM2 Active
		X11=1				PM3 Active
		X12=1				PM4 Active
		X13=1				PM5 Active
		X14=1				PM6 Active
		X15				not used
		X16				not used
A9	169	2 Bytes	D	WP	ALG2	Configuration Index 2
AA	170	Number	D	WP	WAL	Winter Authority Limit
AB	171	Number	D	WP	SAL	Summer Authority Limit

Table 2:
Programmable
Module
Algorithms
Algorithm 1:
On/Off Controller

PM Tag	Type	Alg. Tag	Description
PMxK1	Number	LSP	Local Set Point
PMxI1@	Connection	PV@	Process Variable Source
PMxI2@	Connection	RS@	Remote Set Point Source
PMxI3@	Connection	RV@	Reference Variable Source
PMxTYP	2 Bytes	TYP	Algorithm Options
	X5...X1		Algorithm 1 (00001)
	X6=1		Enable Low Limit (Anti-freeze) Override
	X7=1		Enable Summer Compensation
	X8=1		Enable Winter Compensation
	X9=1		Enable Shutoff & OFF Override
	X10=1		Enable Manual OFF Fan Override
	X11=1		Enable Startup Override
	X12=0		Startup Out Level = 0%
	X12=1		Startup Out Level = 100%
	X13=1	OVR	Enable Air Quality Override
	X14=0		Air Quality Override Out Level = 0%
	X14=1		Air Quality Override Out Level = 100%
	X15=1		Enable Reverse Action
	X16		not used
PMxK2	Number	ACT	Action Type
PMxK3	Number	DIF	Differential
PMxK6	Number	BSB	Set Point Bias During STANDBY
PMxK7	Number	BNT	Set Point Bias During NIGHT

**Algorithm 2:
PI Controller**

PM Tag	Type	Alg. Tag	Description
PMxK1	Number	LSP	Local Set Point
PMxI1@	Connection	PV@	Process Variable Source
PMxI2@	Connection	RS@	Remote Set Point Source
PMxI3@	Connection	RV@	Reference Variable Source
PMxTYP	2 Bytes	TYP	Algorithm Options
	X5...X1		Algorithm 2 (00010)
	X6=1		Enable Low Limit (Anti-freeze) Override
	X7=1		Enable Summer Compensation
	X8=1		Enable Winter Compensation
	X9=1		Enable Shutoff & OFF Override
	X10=1		Enable Manual OFF Fan Override
	X11=1		Enable Startup Override
	X12=0		Startup Out Level = 0% or Low Limit value, whichever is lower
	X12=1		Startup Out Level = 100%
	X13=1	OVR	Enable Air Quality Override
	X14=0		Air Quality Override Out Level = 0% or Low Limit value, whichever is lower
	X14=1		Air Quality Override Out Level = 100%
	X15=1		Enable Reverse Action
	X16=0		0.1% Error Dead Band
	X16=1		1% Error Dead Band
PMxK2	Number	PB	Proportional Band
PMxK3	Number	TI	Integral (Reset) Timing
PMxK4	Number	HIL	Upper Limit of the Control Output
PMxK5	Number	LOL	Lower Limit of the Control Output
PMxK6	Number	BSB	Set Point Bias During STANDBY
PMxK7	Number	BNT	Set Point Bias During NIGHT

**Heating/Cooling
On/Off Controller**
–Algorithm 3:
Single Output
Algorithm 5:
Dual Output

PM Tag	Type	Alg. Tag	Description
Loop 1			
PMxK1	Number	LSP1	Local Set Point
PMxI1@	Connection	PV1@	Process Variable Source
PMxI2@	Connection	RS1@	Remote Set Point Source
PMxI3@	Connection	RV1@	Reference Variable Source
PMxTYP	2 Bytes	TYP1	Algorithm Options
	X5...X1		Algorithm 3 or 5 (00011 or 00101)
	X6=1		Enable Low Limit (Anti-freeze) Override
	X7=1		Enable Summer Compensation
	X8=1		Enable Winter Compensation
	X9=1		Enable Shutoff & OFF Override
	X10=1		Enable Manual OFF Fan Override
	X11=1		Enable Startup Override
	X12=0		Startup Out Level = 0%
	X12=1		Startup Out Level = 100%
	X13=1	OVR1	Enable Air Quality Override
	X14=0		Air Quality Override Out Level = 0%
	X14=1		Air Quality Override Out Level = 100%
	X15=1		Enable Reverse Action
	X16		not used
PMxK2	Number	ACT1	Action Type
PMxK3	Number	DIF1	Differential
PMxK6	Number	BSB1	Set Point Bias During STANDBY
PMxK7	Number	BNT1	Set Point Bias During NIGHT
Loop 2			
PM(x+1)K1	Number	LSP2	Local Set Point
PM(x+1)I1@	Connection	PV2@	not used
PM(x+1)I2@	Connection	RS2@	Remote Set Point Source
PM(x+1)I3@	Connection	RV2@	Reference Variable Source
PM(x+1)TYP	2 Bytes	TYP2	Algorithm Options
	X5...X1		not used
	X6=1		Enable Low Limit (Anti-freeze) Override
	X7=1		Enable Summer Compensation
	X8=1		Enable Winter Compensation
	X9=1		Enable Shutoff & OFF Override
	X10=1		Enable Manual OFF Fan Override
	X11=1		Enable Startup Override
	X12=0		Startup Out Level = 0%
	X12=1		Startup Out Level = 100%
	X13=1	OVR2	Enable Air Quality Override
	X14=0		Air Quality Override Out Level = 0%
	X14=1		Air Quality Override Out Level = 100%
	X15=1		Enable Reverse Action
	X16		not used
PM(x+1)K2	Number	ACT2	Action Type
PM(x+1)K3	Number	DIF2	Differential
PM(x+1)K6	Number	BSB2	Set Point Bias During STANDBY
PM(x+1)K7	Number	BNT2	Set Point Bias During NIGHT

**Heating/Cooling
PI Controller –
Algorithm 4:
Single Output
Algorithm 6:
Dual Output**

PM Tag	Type	Alg. Tag	Description
			Loop 1
PMxK1	Number	LSP1	Local Set Point
PMxI1@	Connection	PV1@	Process Variable Source
PMxI2@	Connection	RS1@	Remote Set Point Source
PMxI3@	Connection	RV1@	Reference Variable Source
PMxTYP	2 Bytes	TYP1	Algorithm Options
	X5...X1		Algorithm 4 or 6 (00100 or 00110)
	X6=1		Enable Low Limit (Anti-freeze) Override
	X7=1		Enable Summer Compensation
	X8=1		Enable Winter Compensation
	X9=1		Enable Shutoff & OFF Override
	X10=1		Enable Manual OFF Fan Override
	X11=1		Enable Startup Override
	X12=0		Startup Out Level = 0% or Low Limit value, whichever is lower
	X12=1		Startup Out Level = 100%
	X13=1	OVR1	Enable Air Quality Override
	X14=0		Air Quality Override Out Level = 0% or Low Limit value, whichever is lower
	X14=1		Air Quality Override Out Level = 100%
	X15=1		Enable Reverse Action
	X16=0		0.1% Error Dead Band
	X16=1		1% Error Dead Band
PMxK2	Number	PB1	Proportional Band
PMxK3	Number	TI1	Integral (Reset) Timing
PMxK4	Number	HIL1	Upper Limit of the Control Output
PMxK5	Number	LOL1	Lower Limit of the Control Output
PMxK6	Number	BSB1	Set Point Bias During STANDBY
PMxK7	Number	BNT1	Set Point Bias During NIGHT

PM Tag	Type	Alg. Tag	Description
Loop 2			
PM(x+1)K1	Number	LSP2	Local Set Point
PM(x+1)I1@	Connection	PV2@	not used
PM(x+1)I2@	Connection	RS2@	Remote Set Point Source
PM(x+1)I3@	Connection	RV2@	Reference Variable Source
PM(x+1)TYP	2 Bytes	TYP2	Algorithm Options
	X5...X1		not used
	X6=1		Enable Low Limit (Anti-freeze) Override
	X7=1		Enable Summer Compensation
	X8=1		Enable Winter Compensation
	X9=1		Enable Shutoff & OFF Override
	X10=1		Enable Manual OFF Fan Override
	X11=1		Enable Startup Override
	X12=0		Startup Out Level = 0% or Low Limit value, whichever is lower
	X12=1		Startup Out Level = 100%
	X13=1	OVR2	Enable Air Quality Override
	X14=0		Air Quality Override Out Level = 0% or Low Limit value, whichever is lower
	X14=1		Air Quality Override Out Level = 100%
	X15=1		Enable Reverse Action
	X16=0		0.1% Error Dead Band
	X16=1		1% Error Dead Band
PM(x+1)K2	Number	PB2	Proportional Band
PM(x+1)K3	Number	TI2	Integral (Reset) Timing
PM(x+1)K4	Number	HIL2	Upper Limit of the Control Output
PM(x+1)K5	Number	LOL2	Lower Limit of the Control Output
PM(x+1)K6	Number	BSB2	Set Point Bias During STANDBY
PM(x+1)K7	Number	BNT2	Set Point Bias During NIGHT

Algorithm 7: Average, Algorithm 8: Minimum, Algorithm 9: Maximum, Algorithm 10: Equation 1, Algorithm 11: Equation 2, Algorithm 12: Equation 3	PM Tag	Type	Alg. Tag	Description
	PMxK1	Number	K1	not used
	PMxI1@	Connection	I1@	Input 1 Source
	PMxI2@	Connection	I2@	Input 2 Source
	PMxI3@	Connection	I3@	Input 3 Source
	PMxTYP	2 Bytes	TYP	Algorithm Options
		X5...X1		Algorithm 7-12 binary code (00111 to 01100)
		X8...X6		not used
		X12...X9		Conditioning Logic Variable 1
		= 0000		No Conditioning
		= 0001		Conditioning from Window Open Status
		= 0010		Conditioning from Occupancy Status
		= 0011		Conditioning from Air Quality Override
		= 0100		Conditioning from Reverse Action Status
		= 0101		Conditioning from General Alarm Status
		= 0110		Conditioning from Low Limit (Anti-freeze) Status
		X16...X13		Conditioning Logic Variable 2
		= 0000		No Conditioning
		= 0001		Conditioning from Window Open Status
		= 0010		Conditioning from Occupancy Status
		= 0011		Conditioning from Air Quality Override
		= 0100		Conditioning from Reverse Action Status
		= 0101		Conditioning from General Alarm Status
		= 0110		Conditioning from Low Limit (Anti-freeze) Status
	PMxK2	Number	K2	Constant 2
	PMxK3	Number	K3	Constant 3
	PMxK4	Number	K4	Constant 4
	PMxK5	Number	K5	Constant 5
	PMxK6	Number	K6	Constant 6
	PMxK7	Number	K7	Constant 7

**Algorithm 13:
Line Segment
Function**

PM Tag	Type	Alg. Tag	Description
PMxK1	Number	K1	not used
PMxI1@	Connection	I1@	Input 1 Source
PMxI2@	Connection	I2@	Input 2 Source
PMxI3@	Connection	I3@	Input 3 Source
PMxTYP	2 Bytes	TYP	Algorithm Options
	X5...X1		Algorithm 13 (01101)
	X13...X6		not used
	X14=1	CND1	Input 1 influences the function output only in COMFORT
	X15=1	CND2	Input 2 influences the function output only in COMFORT
	X16=1	CND3	Input 3 influences the function output only in COMFORT
PMxK2	Number	X0	Break Point X0
PMxK3	Number	Y0	Break Point Y0
PMxK4	Number	X1	Break Point X1
PMxK5	Number	Y1	Break Point Y1
PMxK6			not used
PMxK7			not used

Appendix 2: Configuration Worksheets

The Configuration Worksheets begin on the next page so that they can be easily reproduced.

**Worksheet 1:
Connections**

Project Name: _____ Completed by: _____

Controller: _____ Date: _____

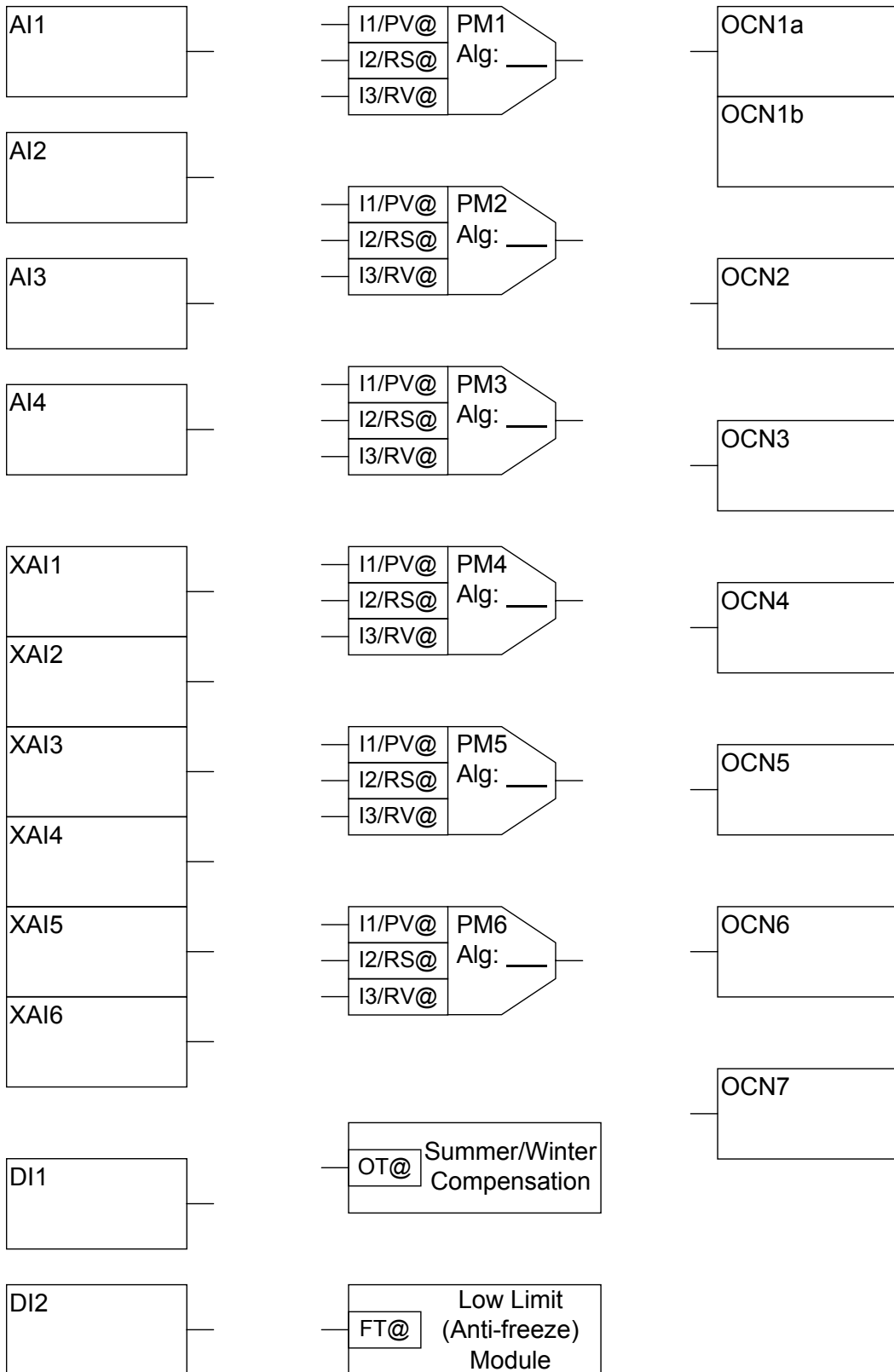

**Worksheet 2:
Configuration
Parameters –
Programmable
Modules**

Project Name: _____ Completed by: _____

Controller: _____ Date: _____

PM 1 – Algorithm No.: _____

Item (hex/dec)	Tag	Value
27/39	PM1K1	
28/40	PM1I1@	
29/41	PM1I2@	
2A/42	PM1I3@	
2B/43	PM1TYP	
2C/44	PM1K2	
2D/45	PM1K3	
2E/46	PM1K4	
2F/47	PM1K5	
30/48	PM1K6	
31/49	PM1K7	

PM 4 – Algorithm No.: _____

Item (hex/dec)	Tag	Value
48/72	PM4K1	
49/73	PM4I1@	
4A/74	PM4I2@	
4B/75	PM4I3@	
4C/76	PM4TYP	
4D/77	PM4K2	
4E/78	PM4K3	
4F/79	PM4K4	
50/80	PM4K5	
51/81	PM4K6	
52/82	PM4K7	

PM 2 – Algorithm No.: _____

32/50	PM2K1	
33/51	PM2I1@	
34/52	PM2I2@	
35/53	PM2I3@	
36/54	PM2TYP	
37/55	PM2K2	
38/56	PM2K3	
39/57	PM2K4	
3A/58	PM2K5	
3B/59	PM2K6	
3C/60	PM2K7	

PM 5 – Algorithm No.: _____

53/83	PM5K1	
54/84	PM5I1@	
55/85	PM5I2@	
56/86	PM5I3@	
57/87	PM5TYP	
58/88	PM5K2	
59/89	PM5K3	
5A/90	PM5K4	
5B/91	PM5K5	
5C/92	PM5K6	
5D/93	PM5K7	

PM 3 – Algorithm No.: _____

3D/61	PM3K1	
3E/62	PM3I1@	
3F/63	PM3I2@	
40/64	PM3I3@	
41/65	PM3TYP	
42/66	PM3K2	
43/67	PM3K3	
44/68	PM3K4	
45/69	PM3K5	
46/70	PM3K6	
47/71	PM3K7	

PM 6 – Algorithm No.: _____

5E/94	PM6K1	
5F/95	PM6I1@	
60/96	PM6I2@	
61/97	PM6I3@	
62/98	PM6TYP	
63/99	PM6K2	
64/100	PM6K3	
65/101	PM6K4	
66/102	PM6K5	
67/103	PM6K6	
68/104	PM6K7	

**Worksheet 3:
Configuration
Parameters –
Input/Output
and General**

Project Name: _____ Completed by: _____

Controller: _____ Date: _____

Analog Inputs

Item (hex/dec)	Tag	Value
6C/108	HIA1	
6D/109	LOA1	
6E/110	HIA2	
6F/111	LOA2	
70/112	HIA3	
71/113	LOA3	
72/114	HIA4	
73/115	LOA4	

Outputs 1 and 2

74/116	OCN1	
75/117	OCO1	
76/118	OCN2	
77/119	OCO2	

Outputs 3 and 4

78/120	OCN3	
79/121	OCO3	
7A/122	OCN4	
7B/123	OCO4	

Outputs 5 and 6

7C/124	OCN5	
7D/125	OCO5	
7E/126	OCN6	
7F/127	OCO6	

Output 7

80/128	OCN7	
81/129	OCO7	

General Parameters

83/131	ALG	
85/133	TCS2	
87/135	TCS1	

Analog Input 1

Item (hex/dec)	Tag	Value
89/137	HRI1	
8A/138	LRI1	
8B/139	FTC1	
8C/140	OFS1	
8D/141	IOP1	

Analog Input 2

8E/142	HRI2	
8F/143	LRI2	
90/144	FTC2	
91/145	OFS2	
92/146	IOP2	

Analog Input 3

93/147	HRI3	
94/148	LRI3	
95/149	FTC3	
96/150	OFS3	
97/151	IOP3	

Analog Input 4

98/152	HRI4	
99/153	LRI4	
9A/154	FTC4	
9B/155	OFS4	
9C/156	IOP4	

Summer/Winter Compensation

9F/159	OT@	
A0/160	SPW	
A1/161	SPS	
A2/162	WA	
A3/163	SA	
AA/170	WAL	
AB/171	SAL	

Low Limit (Anti-freeze) Module

A4/164	FT@	
A5/165	FSP	
A6/166	FDIF	

Notes



Johnson Controls International, Inc.

Headquarters: Milwaukee, Wisconsin, USA

European Customer Service Center: Westendhof 3, D-45143 Essen, Germany

European Factories: **Essen, Germany and Lomagna, Italy**

Branch Offices: Principal European Cities

www.johnsoncontrols.com

Issued in Europe