



techsystem

automatyka klimatyzacja wentylacja

▸ zapoznaj się z naszą ofertą

TC-9102 Fan Coil Unit Controller

Introduction	Page 3
• <i>Model Types</i>	4
• <i>Controller Functions</i>	5
• <i>Output Types</i>	10
• <i>Fan Output Types</i>	12
Installation	15
• <i>Mounting</i>	15
• <i>Wiring</i>	16
• <i>Jumper and Switch Selections</i>	22
• <i>Startup</i>	23
• <i>Commissioning</i>	24
Specifications & Technical Data	25
• <i>Factory-Set Parameters</i>	26
• <i>Parameters for Supervisory System</i>	27
• <i>Ordering Codes</i>	28

Introduction

The TC-9102 series of microprocessor-based controllers is designed for the control of Fan Coil Units (FCUs) with heating and cooling, and a single-speed, 3-speed or variable-speed fan. The controller can regulate water valves, one or 2-stage electric heating, or a cooling unit where the compressor has its own short cycle protection.

The comfort temperature set point of the controller may be adjusted via a **TM-1100** Series Room Command Module, and the occupied and unoccupied control modes of operation temporarily changed. A window open sensing contact may be connected to switch the controller to the off mode, and a low temperature limit protection feature is available.

The controller is factory-configured to control with default operating parameters so that no external setup devices are necessary. However, a software package for a PC is available to verify the correct operation of the controller and to modify the configuration, if necessary.

Winter and summer compensation may be enabled when the controller receives outdoor air temperature data via the communications bus, and modes of operation may be set by time scheduling programs or control processes in the supervisory system.



Figure 1: TC-9102 Controller

Figure 2: **TM-1160** Room Command Module



2333

Figure 3: TM-9180 Room Command Module

Note: The TM-9180 Room Command Module is only available as a replacement part from July 2006.

Model Types

The TC-9102 Controller is available in several model types according to the type of outputs and the range of the integrated or remote set point input. Refer to *Ordering Codes* at the end of this bulletin for details.

Controller Functions

The controller can be connected to a Room Command Module, from which it receives the room temperature, the remote set point and other override signals. **The Room Command Modules (TM-1100 series) provide the signals as individually connected physical inputs to the controller. The TM-9180 intelligent Room Command Module provides these signals via a serial bus connection to the controller.** In addition, an NTC temperature sensor is available for mounting within the FCU.

For installations without a Room Command Module, the controller is available with an integrated set point adjuster. Alternatively, the remote set point and fan override controls may be incorporated into a custom FCU control panel. Refer to the *Specifications and Technical Data* section of this bulletin for details of the components required.

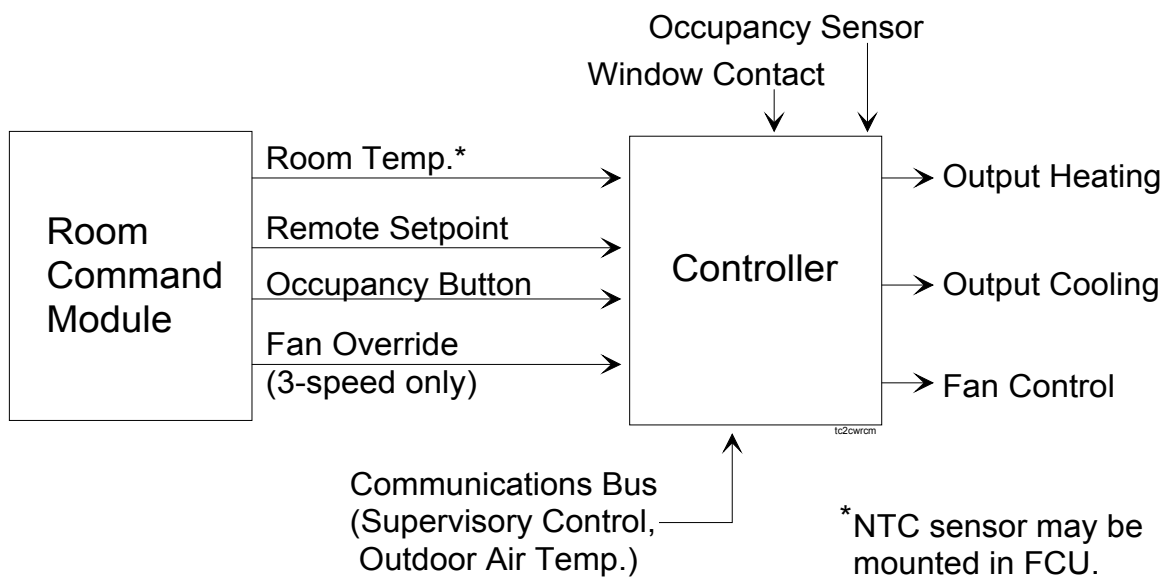

Figure 4: Controller with Room Command Module

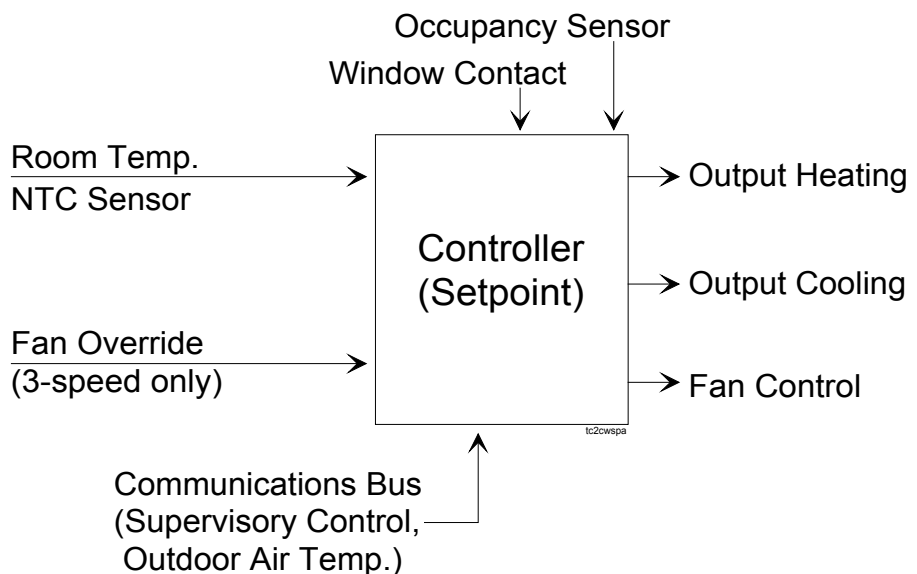

Figure 5: Controller with Integrated Setpoint Adjuster

Standalone Mode

The controller operates in standalone mode when it is not connected to a supervisory system via the communications bus nor to a TM-9180 Room Command Module. In standalone mode the controller may operate in one of three control modes:

- COMFORT (occupied): control at comfort set point
- STANDBY (unoccupied): control at a standby level set point
- OFF (not in use): low limit control only

The control modes are set by the window contact and occupancy sensor inputs, and may be modified by the occupancy button on the Room Command Module as shown in Table 1.

Table 1: Standalone Modes

WINDOW CONTACT	OCCUPANCY SENSOR	CONTROL MODE	ALTERNATE MODE (OCCUPANCY BUTTON)
WINDOW OPEN	NO ACTION	OFF	NO ACTION
WINDOW CLOSED	OCCUPIED	COMFORT	STANDBY
	UNOCCUPIED	STANDBY	COMFORT

Supervisory Mode

When connected to a supervisory system via the communications bus or to a TM-9180 Room Command Module, the controller may operate in COMFORT, STANDBY or OFF control modes, and additionally in NIGHT mode:

- **NIGHT (scheduled unoccupied): control at a night level set point.**

The control modes are set by the supervisory system or TM-9180, and are modified by the occupancy sensor input and occupancy button on the Room Command Module as shown in Table 2. An open window contact input always switches the controller to OFF control mode, and a MANUAL mode is available from the supervisory system to inhibit the action of the occupancy sensor and occupancy button.

Table 2: Supervisory Modes

WINDOW CONTACT	SUPERVISORY MODE	OCCUPANCY SENSOR	CONTROL MODE	ALTERNATE MODE (OCCUPANCY BUTTON)	
OPEN	ANY MODE	NO ACTION	OFF	NO ACTION	
CLOSED	OFF	OCCUPIED	OFF	OFF	
		UNOCCUPIED	OFF	OFF	
	NIGHT	OCCUPIED	NIGHT	COMFORT (T)*	
		UNOCCUPIED	NIGHT	COMFORT (T)*	
	STANDBY	OCCUPIED	STANDBY	COMFORT	
		UNOCCUPIED	STANDBY	COMFORT (T)*	
	COMFORT	OCCUPIED	COMFORT	STANDBY	
		UNOCCUPIED	STANDBY	COMFORT	
	OFF/MANUAL	NO ACTION		OFF	NO ACTION
	NIGHT/MANUAL			NIGHT	
	STANDBY/MANUAL			STANDBY	
	COMFORT/MANUAL			COMFORT	

*(T) = Timed (Returns to Control Mode after 1 hour.)

Controller Set Points

The set point in all control modes may be modified from the integrated set point adjuster or from the remote set point dial/control panel on the Room Command Module, according to the controller model type. The controller models with a remote set point of 12-28°C require that a Room Command Module or an external potentiometer is connected to give the set point. Controllers with a remote set point of +/-3 K have internal factory set points of 20°C for heating and 22°C for cooling.

The set point is decreased or increased in the STANDBY control mode by the factory-set “Standby Bias Heating” and “Standby Bias Cooling” values to reduce the heating or cooling energy required when the room is temporarily unoccupied.

When a supervisory system or TM-9180 with time scheduling is connected, the set point can be further decreased or increased in the NIGHT control mode to further reduce energy requirements during scheduled unoccupied periods such as nights, weekends and holidays.

In the controller there are two “comfort” set points (Comfort Set Point Heating and Comfort Set Point Cooling), and the difference between these two values determines the zero energy band where neither heating nor cooling is required. The controller calculates two working set points (WSP Heating and WSP Cooling), which are the sum of the “Comfort Set Point” value, the “Remote Set Point” value coming from the integrated set point adjuster or the Room Command Module, and the “Common Set Point” value. In the supervisory mode an adjustment may be made to the working set points either by changing the “Comfort Set Points” or by changing the value in the “Common Set Point” parameter of the controller which enables the supervisory system operator to adjust the setpoints for heating and cooling at the same time without affecting the zero energy band. In summary:

Working Set Point (Heating) = Comfort Set Point (Heating) (Supervisory System)
+ Remote Set Point (integrated adjuster or Command Module dial)
+ Common Set Point (Supervisory System)
+ STANDBY or NIGHT Bias Heating (if mode is active)

Working Set Point (Cooling) = Comfort Set Point (Cooling) (Supervisory System)
+ Remote Set Point (integrated adjuster or Command Module dial)
+ Common Set Point (Supervisory System)
+ STANDBY or NIGHT Bias Cooling (if mode is active)

When the room temperature is below the working set point for heating, the heating output increases according to the proportional band and integral time parameters set for the heating control loop. When the room temperature is above the working set point for cooling, the cooling output increases according to the proportional band and integral time parameters set for the cooling control loop. Heating and cooling control is illustrated in figures 8 and 9.

Alternate Mode

When pressed for about one second, the occupancy button on the Room Command Module changes the mode of operation of the controller to the “Alternate Mode” or back to the normal “Control Mode” as shown in Table 2. The COMFORT (T) alternate mode is active only for a period of one hour, after which the controller reverts to the normal control mode.

Fan Control

The controllers with on/off fan control switch the fan on when the room temperature is below the working set point for heating and above the working set point for cooling, and switch the fan off when the room temperature has entered the zero energy band by the value set for the fan differential. The fan can optionally be set to continue running in the zero energy band in the COMFORT (occupied) mode, using the software commissioning tool.

In controllers with 3-speed fan control outputs, the fan stages are switched in sequence as the room temperature decreases or increases, and Speed I remains on in the zero energy band.

In controllers with a 0 to 10 VDC output for a fan speed controller, the output increases as the room temperature falls below the working set point for heating or rises above the working set point for cooling, and maintains a minimum output (set by default at 50%) when the room temperature has entered the zero energy band.

For all controllers, in OFF mode the fan is switched off and the heating and cooling outputs are set to the fully closed or off level. Fan control sequences are shown in figures 10, 11 and 12.

3-Speed Fan Override

The speed of a 3-speed fan may be set manually from the Room Command Module when the controller is in COMFORT (occupied) mode. In the **AUTO** position the speed is set by the controller according to the room temperature. In the manual **OFF - I - II - III** positions the fan runs at the selected speed. The fan override is not active in STANDBY, NIGHT or OFF modes.

In controller models with 2-stage on/off heating and cooling outputs, all outputs are switched off when the fan speed is set to **OFF** to protect electrical heating and cooling devices that require a minimum air flow for normal operation. This feature can be enabled for other types of outputs, if required, using the software commissioning tool. Refer to *Commissioning* later in this document.

Low Limit Mode

The low limit mode is active when the room temperature falls below the low limit set point. The fan is switched on at full speed and the heating output is set to the maximum level until the room temperature rises by the low limit differential value.

Winter/Summer Compensation

When the controller is connected to a supervisory system, the winter and/or summer compensation modes may be enabled. The supervisory system must be programmed to set the outdoor air temperature via the communications bus on a periodic basis. After a power interruption the winter and summer compensation modes are temporarily disabled until a new outdoor air temperature value is received. When the outdoor air temperature falls below the winter set point, the working set point of the controller will be raised or lowered in accordance with the winter authority slope. When the outdoor temperature rises above the summer set point the working set point of the controller will be raised in accordance with the summer authority slope. The maximum amount of compensation is limited by the Winter Authority Limit and the Summer Authority Limit.

The effect of the winter and summer compensation on the controller set point is shown below.

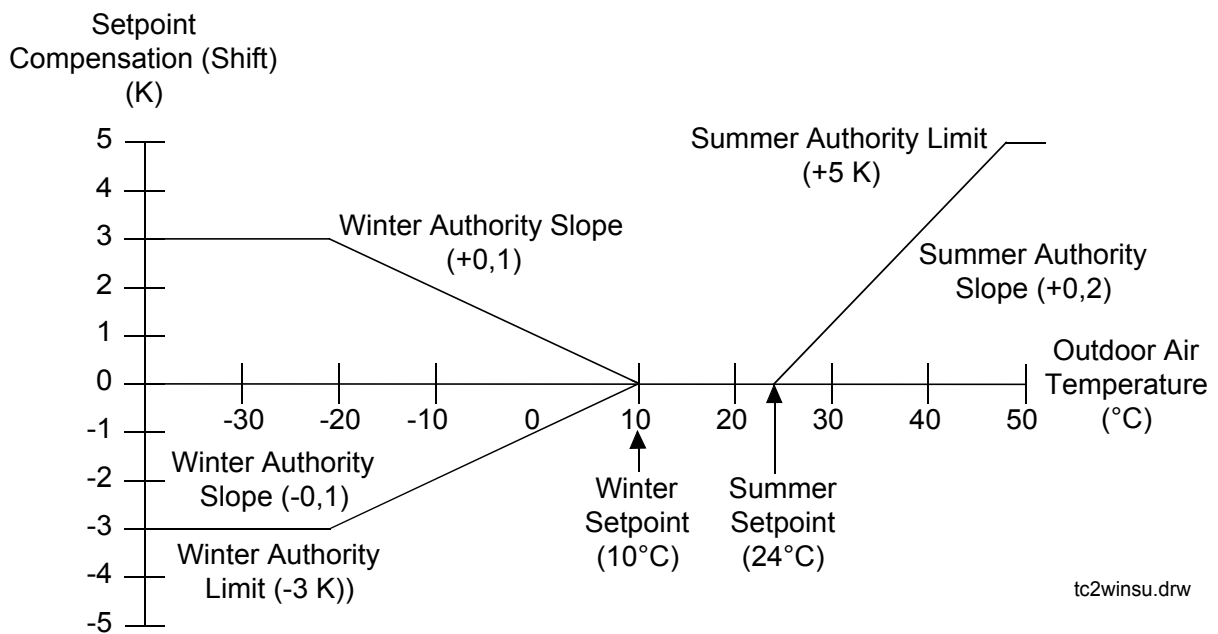

Figure 6: Winter/Summer Compensation

Auto-dial Feature

When the controller is connected to a remote N2 Bus and supervised by a Metasys N2 Dialer (NU-NDM101-0) which is linked to a Metasys network by a telephone line, the following alarm conditions in the controller will initiate the automatic dial feature:

- Window Open
- Low Limit mode
- High or low alarm limit violation of the room temperature when alarm limits have been set by the supervisory system.

When any one of these alarm conditions occurs, the N2 Dialer will detect the alarm and connect the remote N2 Bus to the Metasys network. When the telephone line connection is established the controller alarm status will automatically be reset and the controller is then ready to report further alarm conditions as they occur. *Refer to the Technical Bulletin of the NU-NDM101-0 for further information.*

Output Types

The heating and cooling outputs are one of the following types, depending on the controller model code:

0 - 10 VDC

The output is an analog voltage between 0 and 10 VDC in direct proportion to the controller output from 0 to 100%.

DAT - Duration Adjust Type

The DAT output is a triac which is switched on for a duration within the set heating or cooling valve cycle time in direct proportion to the controller output from 0 to 100%. To avoid unnecessary switching of the valve actuator when the output is between 0 and 5% the triac remains off, and when the output is between 95 and 100% the triac remains on. The default cycle time is 300 seconds.

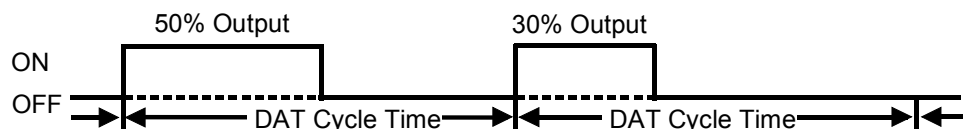

Figure 7: DAT Output

PAT - Position Adjust Type

The PAT output is a pair of triacs which are switched on to open and close an incrementally driven heating or cooling valve. The duration of switching is directly proportional to the change in the controller output and related to the full stroke time of the valve such that a 100% change will completely open or close the valve. At the 0% or 100% position the duration of switching is increased to ensure that the valve is completely at its end position and the appropriate triac is switched on for the full stroke time every two hours to ensure that the valve remains at its end position. To prevent unnecessary wear on the actuator, the triac output will only be switched when the output change exceeds 1% in the same direction as the previous change or 2% if the direction of change is reversed. The default full stroke time is 60 seconds.

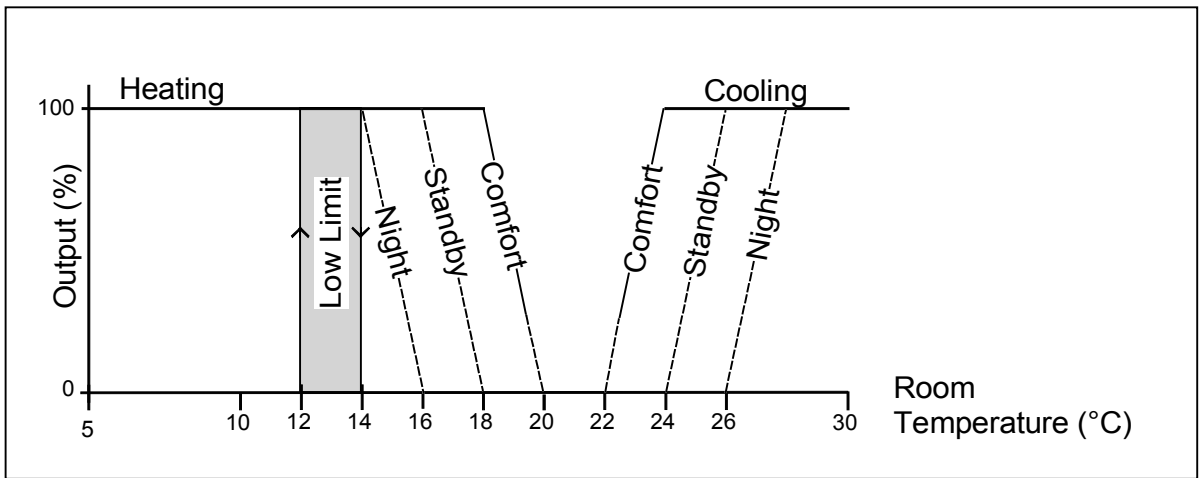

Figure 8: Heating/Cooling Control 0-10 VDC, DAT, PAT

2-Stage On/Off

The output is a pair of triacs which are switched on in sequence as the controller output increases. The first stage triac is switched as soon as the output is above 0% and the second stage triac is switched when the output is equal to the set load rating for the first stage which is defaulted to 50%. The switching differential is fixed at 5%. When this type of output is used with 3-speed fan control, the output will be switched off whenever the fan speed is manually overridden to the “OFF” position on the Room Control Module. The control diagram is shown below.

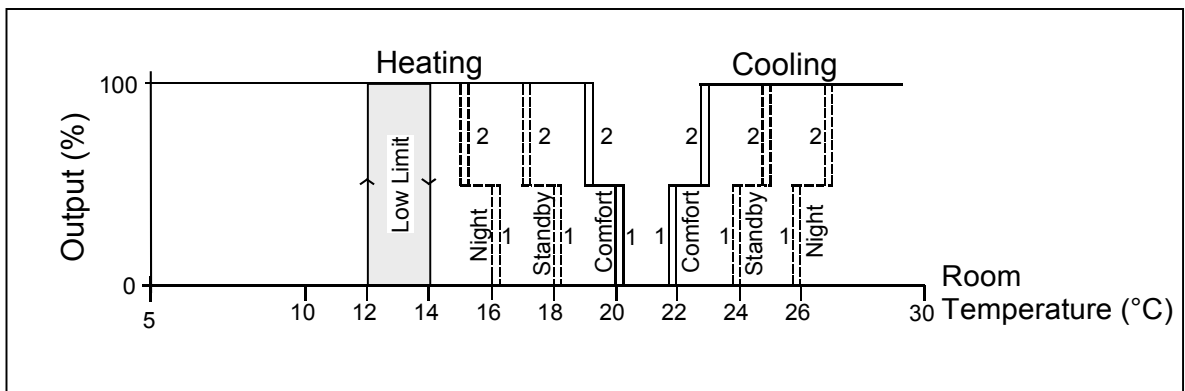

Figure 9: Heating/Cooling Control - 2-Stage On/Off

Fan Output Types

Fan On/Off

The output is a normally open relay contact which closes when the fan is required to run. Terminals are provided to connect the fan supply voltage to the controller in order to facilitate the wiring to the fan motor. The fan supply voltage is not used within the controller.

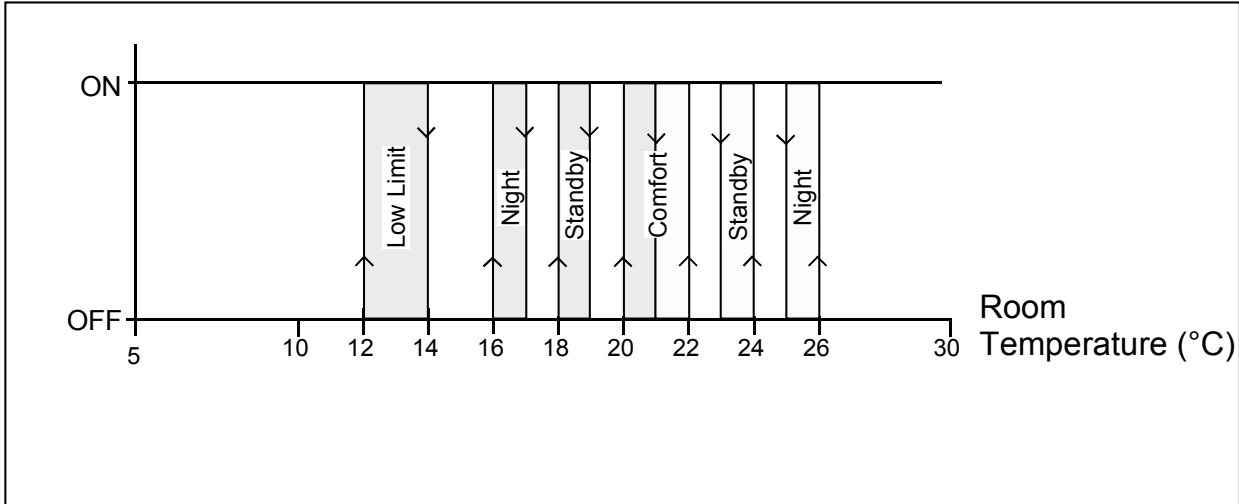
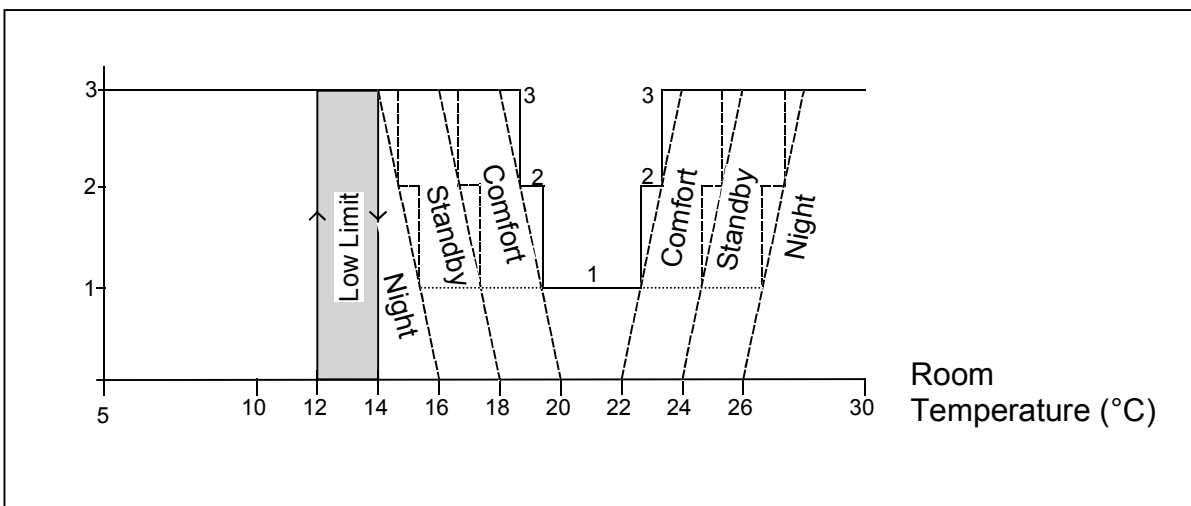

Figure 10: On/Off Fan Control - Switch Points

3-Speed Fan Control

The output is a set of interlocked relay contacts, one contact for each speed which closes when that speed is selected to run. Terminals are provided to connect the fan supply voltage to the controller in order to facilitate the wiring to the fan motor. The fan supply voltage is not used within the controller.



tc2swpts

Figure 11: 3-Speed Fan Control - Switch Points

**0 to 10 VDC
Control Signal**

The output is a control signal for driving a fan speed controller with an opto-isolated 0 to 10 VDC input. As the output voltage increases, the fan speed controller must increase the speed of the fan from the minimum speed of the fan motor to its maximum speed. When the output is below the voltage required for the minimum speed, the fan must be switched off.

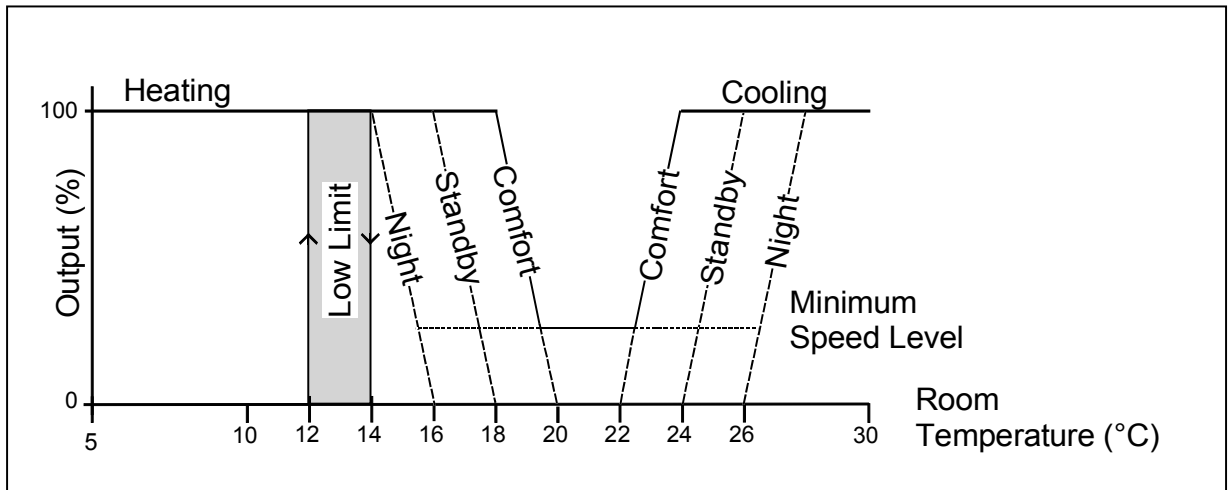

tc2facos

Figure 12: 0 to 10 VDC Fan Control Signal

Installation

The TC-9102 series controller is designed to be mounted within the Fan Coil Unit housing or within a control cabinet. The mounting location must be clean and dry, and not subject to extreme heat or cold. The installation and electrical wiring must conform to local codes and should be carried out by authorized personnel only. Users should ensure that all Johnson Controls' products are used safely and without risk to health or property.

Mounting

For surface mounting, slide the two mounting brackets into the slots at opposite corners of the controller base behind the terminals. Fix to the surface using the 4-mm diameter self-tapping screws.

For DIN rail mounting, place the controller on the upper edge of the rail and press the controller firmly against the rail until the spring-loaded clip engages the lower edge of the rail. To remove the controller, insert a screw driver into the clip at the base of the controller and pull the clip downwards to release. Alternatively, lift the controller upwards against the spring of the retaining clip and pull forward from the top.

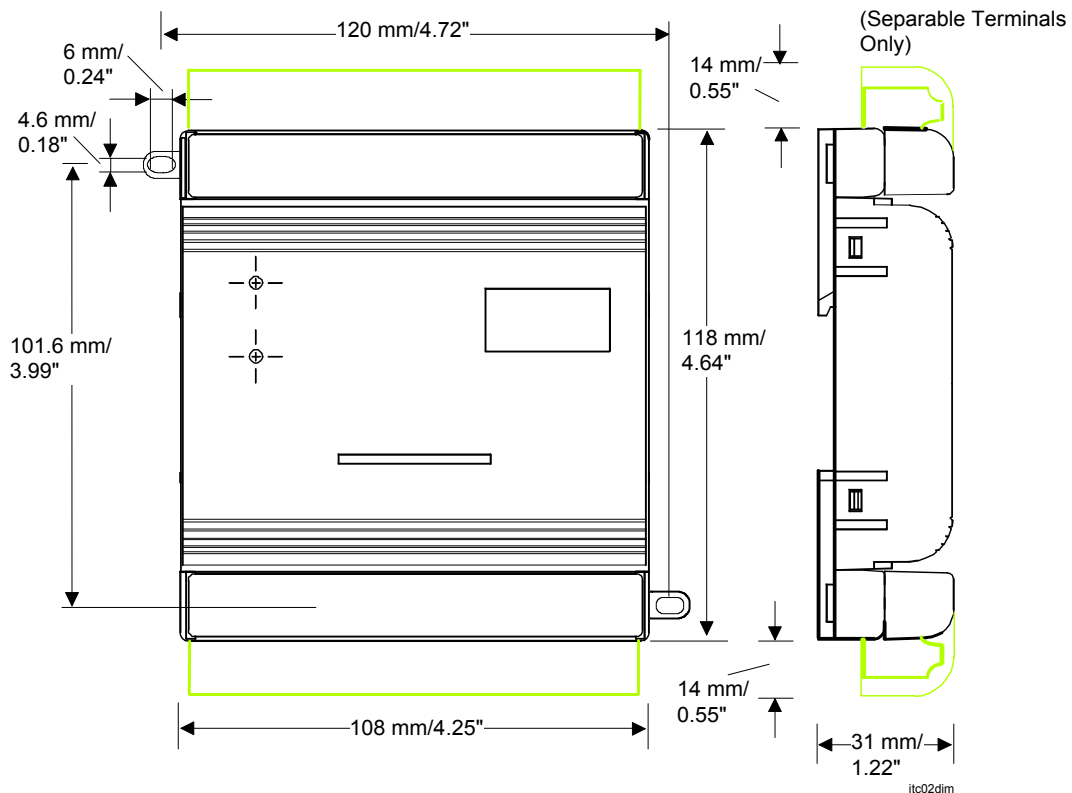

Figure 13: TC-9102 Controller Dimensions

Note: A minimum of 25 mm of space is required above and below the controller for the removal of separable terminals.

Wiring

Before connecting or disconnecting any wires, ensure that all power supplies have been switched off and all wires are potential-free to prevent equipment damage and avoid electrical shock.

Terminations are made on the terminal blocks, at the top and bottom of the controller, which accept up to 1.5mm² wires. Follow the wiring diagrams shown in figures 14 to 20.

When the TC-9102 model with separable terminal blocks is being wired, it is recommended that the removable parts of the blocks be unplugged before terminating the wires, and that they are not plugged in again until the wiring has been fully checked.

Separate **safety extra low voltage (SELV)** wiring from power line voltage wiring. A distinctive colour such as white or pink is recommended for low voltage wiring. Keep all cables as short as possible and tie in position. Do not run cables close to transformers or high frequency generating equipment.

The 24 V supply must be stable and not shared with other switched inductive loads. When multiple loads are connected to one transformer, wire each load from the transformer separately so that any possible disturbances from one load will have minimal effect on other loads.

Complete and verify all wiring connections before continuing with the installation procedure.



CAUTION: Connections to the on/off or 3-speed fan control terminals may carry up to 250 VAC. Isolate live and neutral supply lines (double-pole switch) before servicing.

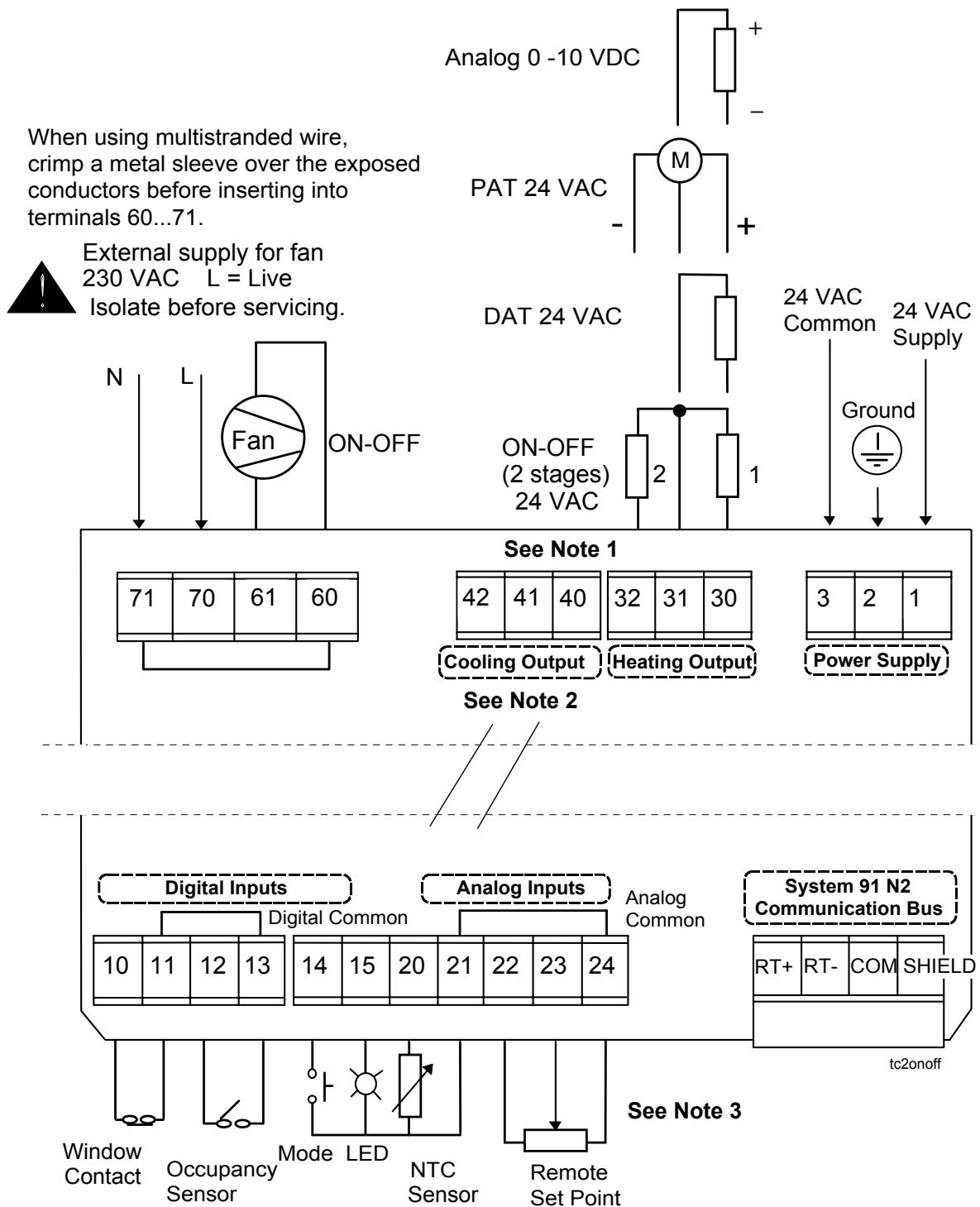

- Note 1: For PAT, DAT and ON-OFF outputs, terminals 1, 31 and 41 are internally connected.
For 0-10 VDC outputs, terminals 30 and 40 are internally connected.
- Note 2: Wiring for Cooling Output is the same as shown for Heating Output.
- Note 3: See also figures 17-20 for Room Command Module Wiring. An External Remote Set Point cannot be connected to models with an integral set point (TC-9112).

Figure 14: TC-9102 Controller Wiring - On/Off Fan Control

When using multistranded wire, crimp a metal sleeve over the exposed conductors before inserting into terminals 60...71.

 External supply for fan
230 VAC L = Live
Isolate before servicing.

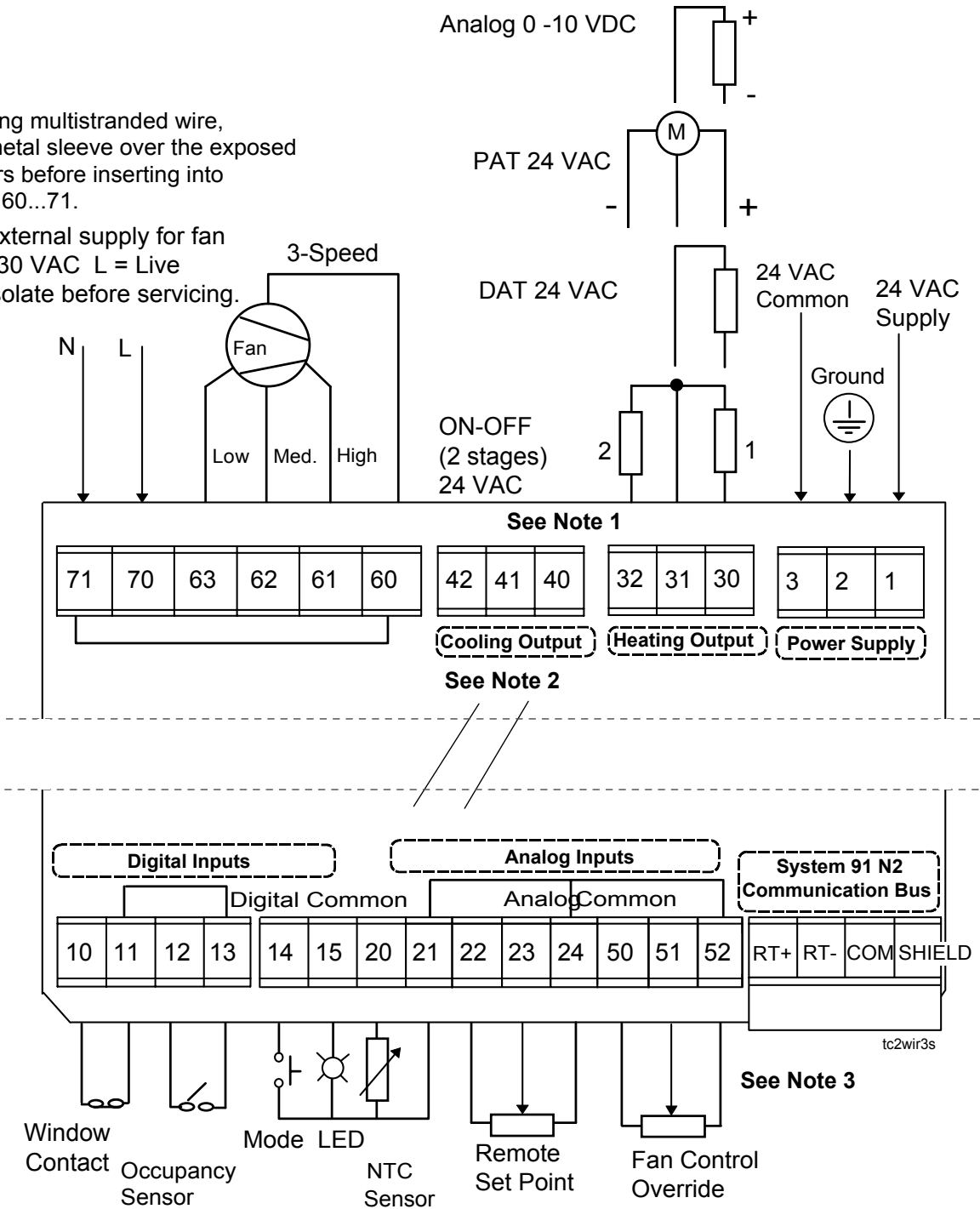

- Note 1: For PAT, DAT and ON-OFF outputs, terminals 1, 31 and 41 are internally connected.
For 0-10 VDC outputs, terminals 30 and 40 are internally connected.
- Note 2: Wiring for Cooling Output is the same as shown for Heating Output.
- Note 3: See also figures 17-20 for Room Command Module Wiring. An External Remote Set Point cannot be connected to models with an integral set point (TC-9112).

Figure 15: TC-9102 Controller Wiring - 3-Speed Fan Control

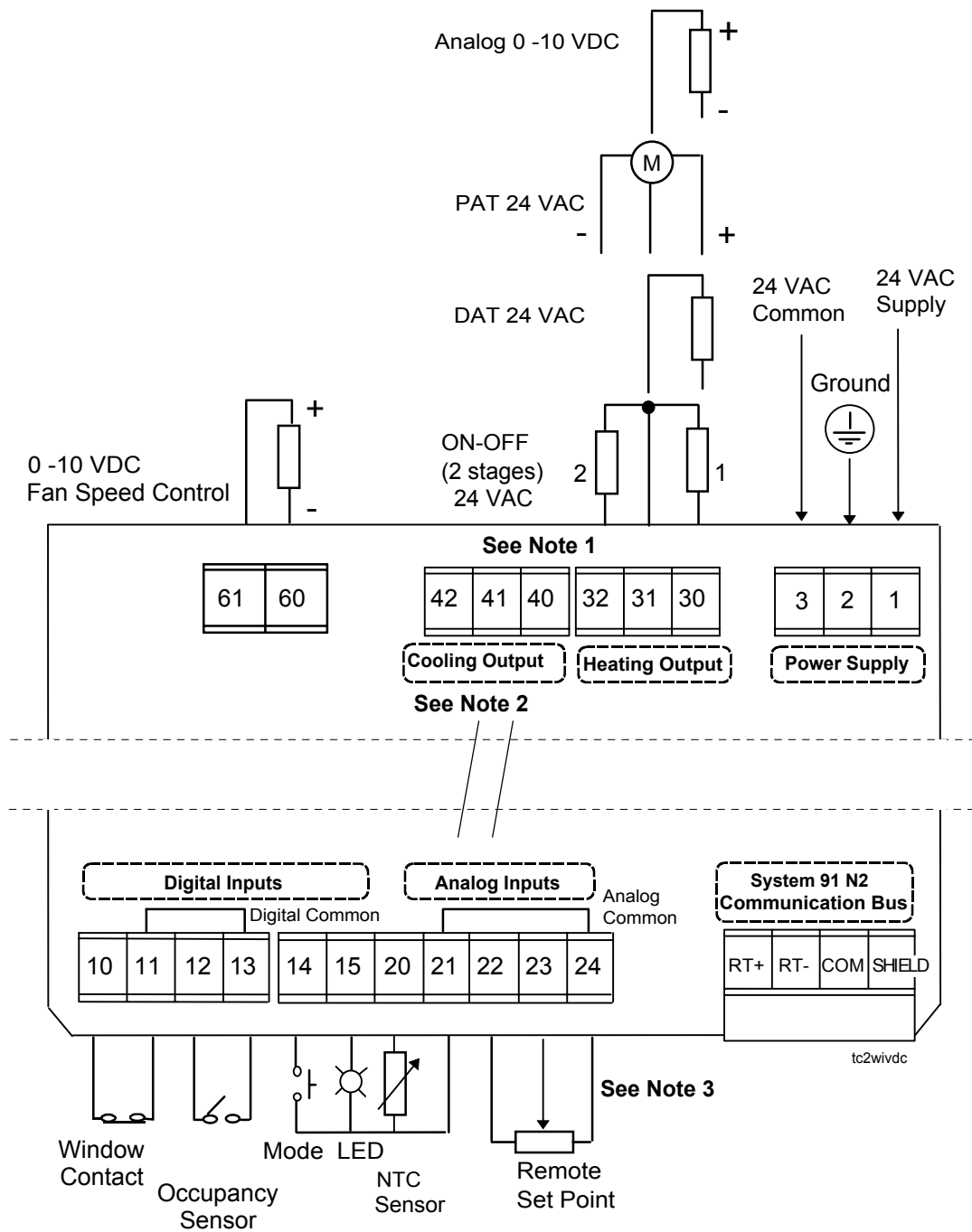

Note 1: For PAT, DAT and ON-OFF outputs, terminals 1, 31 and 41 are internally connected.

For 0-10 VDC outputs, terminals 30, 40 and 60 are internally connected.

Note 2: Wiring for Cooling Output is the same as shown for Heating Output.

Note 3: See also figures 17-20 for Room Command Module Wiring. An External Remote Set Point cannot be connected to models with an integral set point (TC-9112).

Figure 16: TC-9102 Controller Wiring - 0 to 10 VDC Fan Control

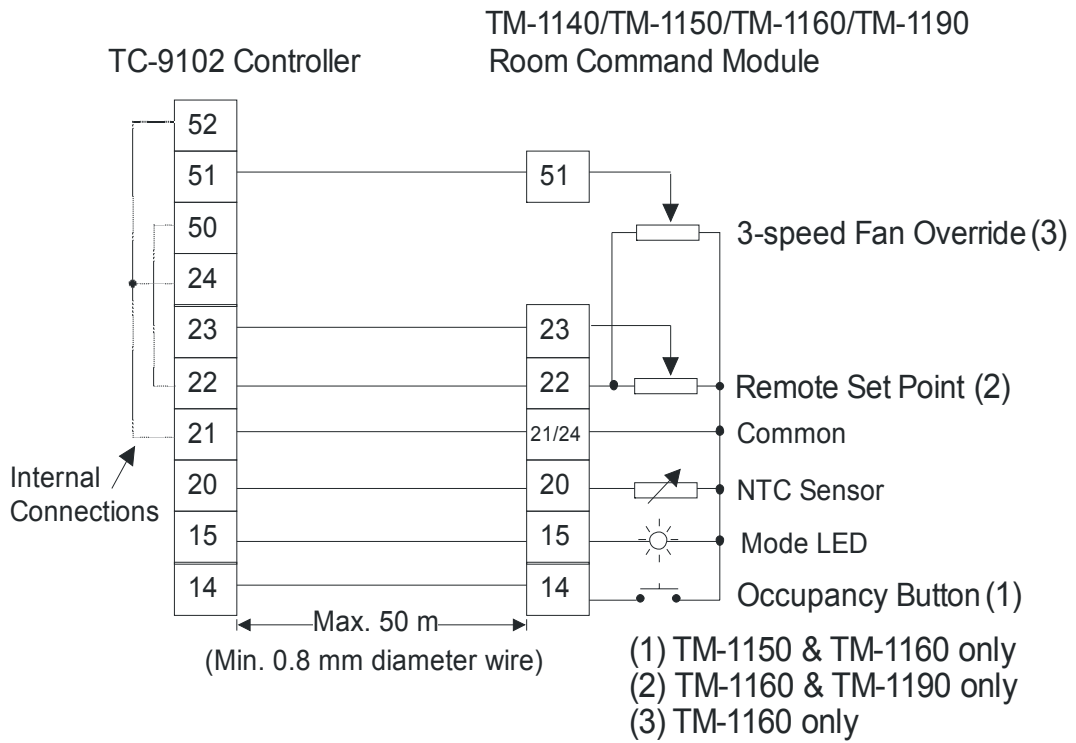

Figure 17: TC-9102 Controller Wiring to Room Command Module with Integral NTC Sensor

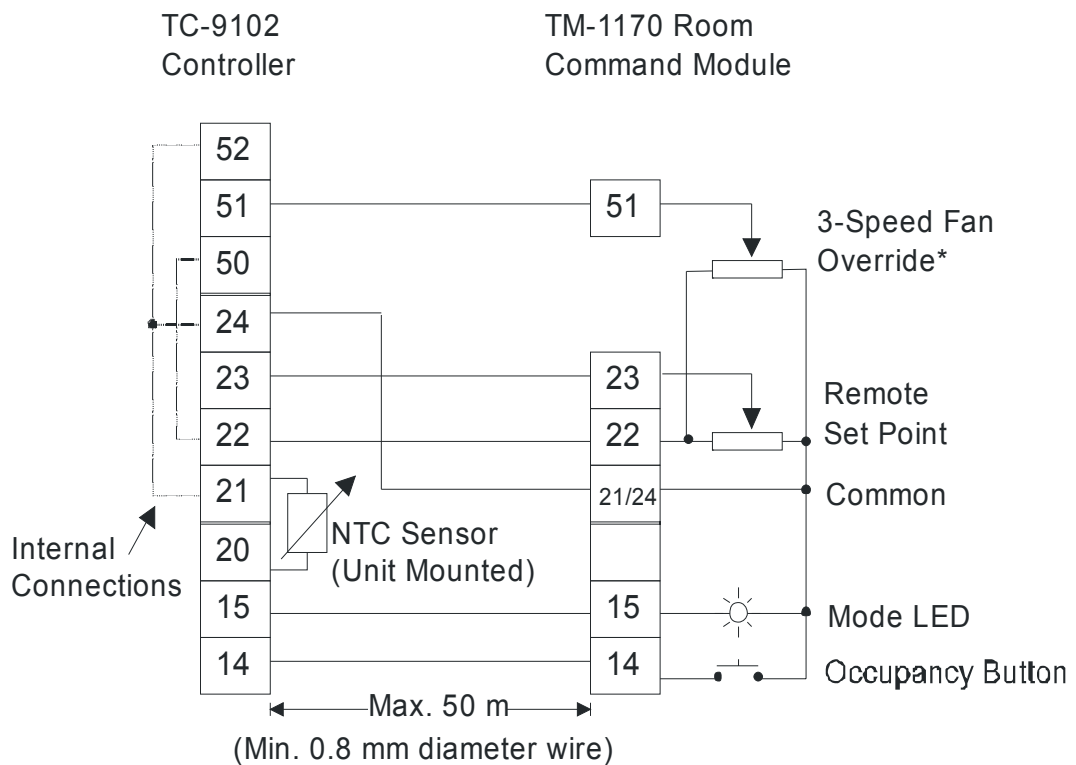

Figure 18: TC-9102 Controller Wiring to Room Command Module with Unit Mounted NTC Sensor

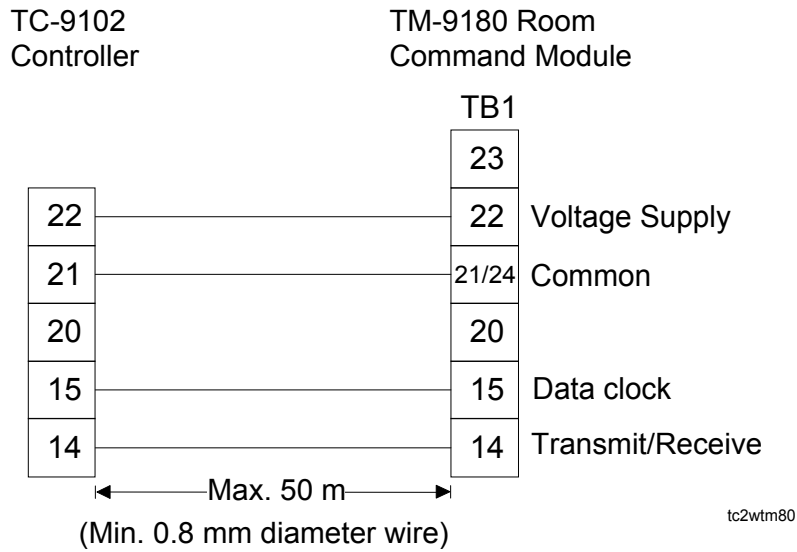

Figure 19: TC-9102 Controller Wiring to TM-9180 Room Command Module

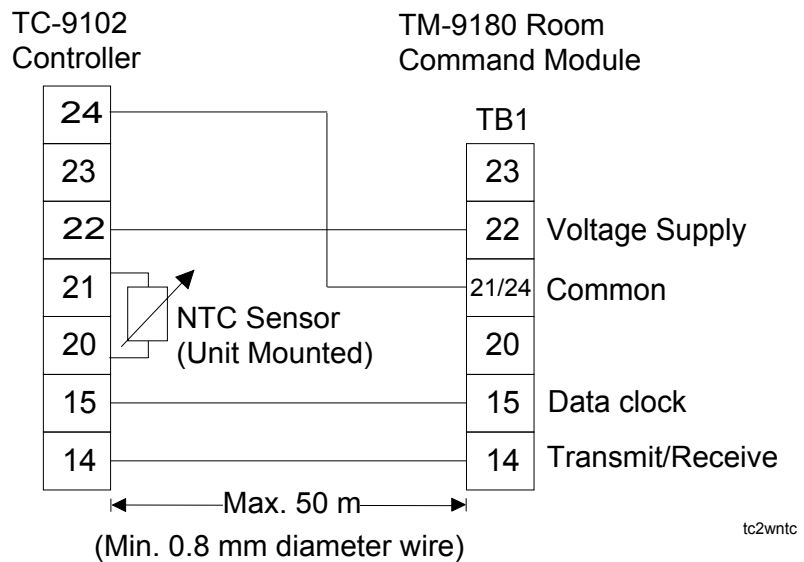

Figure 20: TC-9102 Controller Wiring to TM-9180 Room Command Module with Unit Mounted NTC Sensor

Jumper and Switch Selections



CAUTION: Connections to the on/off or 3-speed fan control terminals may carry up to 250 VAC. Isolate live and neutral supply lines (double-pole switch) before servicing.

To reach the jumpers and switches, open the controller by gripping the cover with thumb and finger on both sides above center and pull the cover off using the lower edge as a hinge. Replace the cover by resting the lower edge of the cover against the base and then pressing the cover firmly to engage all four retaining lugs.

Address Switches and Zone Jumpers

If the controller is connected to a communications bus, a network address must be set. Refer to the project documentation for the address setting for the controller. Addresses 0 to 63 can be set on the address switches. The zone jumpers allow addressing up to 255 as follows:

Zone 1 Jumper	Zone 2 Jumper	Address Switch	Network Address
OUT	OUT	0 to 63	0 to 63
IN	OUT	0 to 63	64 to 127
OUT	IN	0 to 63	128 to 191
IN	IN	0 to 63	192 to 255

The setting on the Address Switches is in binary format:

Switch Number:	1	2	3	4	5	6
Decimal Equivalent:	1	2	4	8	16	32

Example (Address 43):

Switch Number:	1	2	3	4	5	6	
Switch Position:	ON	ON	OFF	ON	OFF	ON	
Decimal Equivalent:	43 =	1 +	2 +	0 +	8 +	0 +	32

Jumpers

Remove the **Gain Jumper JP2 (RED)** to reduce the proportional band to half of the factory setting (gain x 2). (Factory setting is 2K.)

When the **Integral Time Jumper JP2 (BLUE)** is not installed (as delivered by the factory), the integral action of the controller is disabled. Insert the jumper to obtain the factory set default value of four minutes (0.25 repeats per minute).

Set Jumpers **JP3** as shown in Figure 20, depending on whether a TM-9180 with LCD Display (lower position) or a **TM-1100 series module** (upper position) is connected.

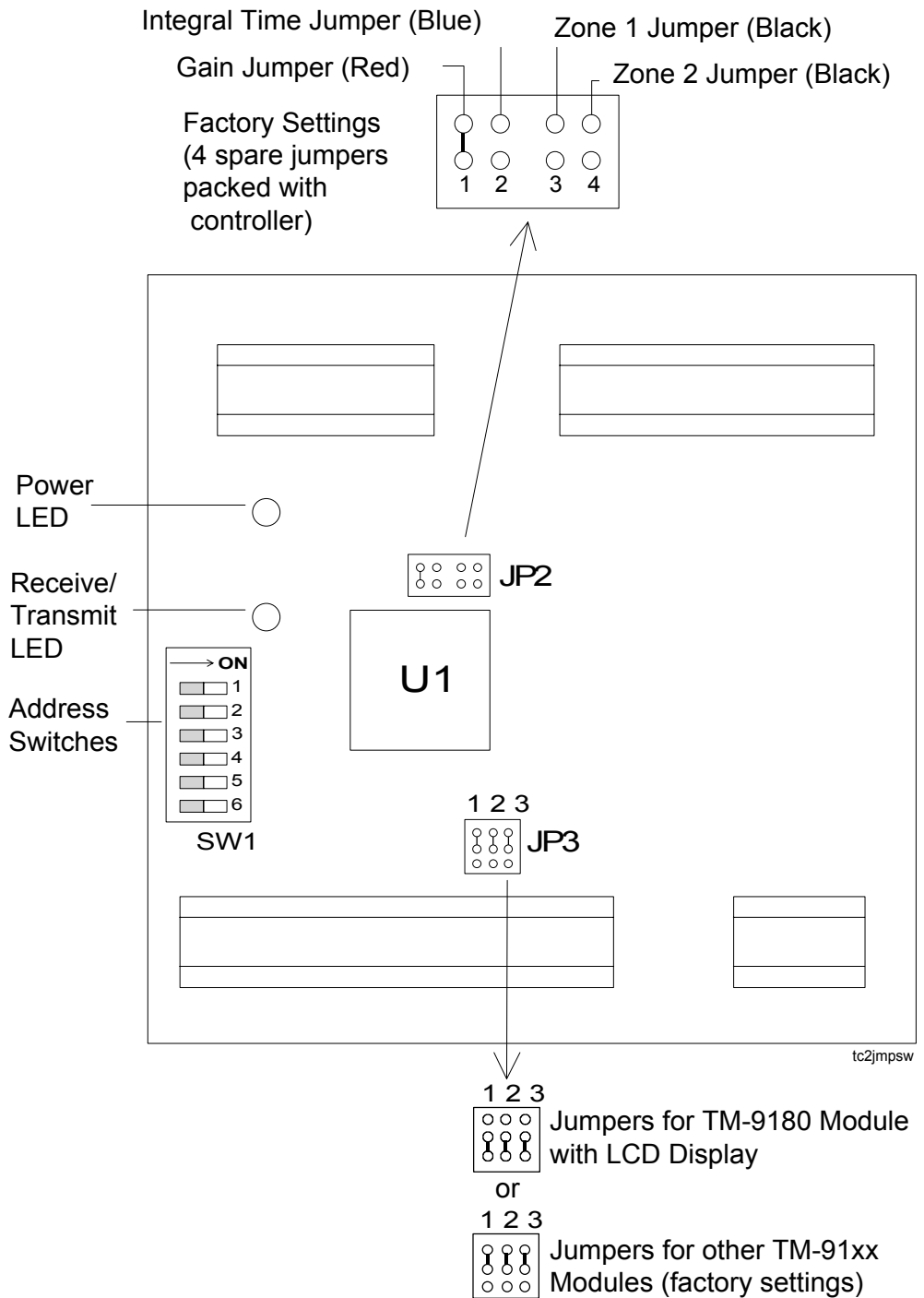

Figure 21: TC-9102 Controller Jumpers and Switches

Startup

When all jumpers and address switches have been set, and all connections have been made and verified, 24 VAC power may be applied. The Power LED should be lit. If the communications bus is active the R/T LED will flash. If the Power LED is not lit, check the 24 V supply.

Commissioning

The Configuration Tools for Windows® (MW-MTOOLE-0) or TC-9100 Commissioning Tool software (TC-9100-TOOL) running on a PC is required to verify the operation of the controller and to change parameters. Refer to the *Configuration Tools for Windows Manual* or the *TC-9100 Commissioning Tool User's Guide* for further information.

Specifications & Technical Data

Supply Voltage	24 VAC, +15% to -10%, 50-60 Hz.	
Power Consumption	3 VA for controller and room command module. (Add power consumption of connected actuating devices.)	
Ambient Operating Conditions	0° to 50°C 10 to 90% RH noncondensing	
Ambient Storage Conditions	-20° to 70°C 10 to 90% RH noncondensing	
Terminations	Screw terminal blocks for 1.5 mm ² (maximum) cable. Separable terminal blocks are available as an option.	
Communication Interfaces	Optically isolated RS-485 interface for N2 bus connection at 9600 baud. Room Command Module (TM-9180) interface at 600 baud - non-isolated synchronous bus.	
Controller Addressing	0-255 selectable on DIP switches (6) and jumpers (2)	
Inputs	Window Contact:	Closed (<1 KOhm) = window closed
	Occupancy Sensor:	Closed (<1 KOhm) = occupied
	Room Temperature Sensor:	NTC Thermistor 0-40 °C*
	Remote Set Point:	10 KOhm potentiometer*
	3-Speed Fan Override:	10 KOhm potentiometer*
	Occupancy Button:	Momentary Contact*
	*from Room Command Module TM-1140/1150/1160/1170/1190	
Outputs	Heating/Cooling	
	Analog:	0-10 VDC, maximum 10 mA
	DAT:	Triac rated at 24 VAC, maximum 0.5 A*
	PAT:	2 x triacs rated at 24 VAC, maximum 0.5 A*
	2-Stage On/Off:	2 x triacs rated at 24 VAC, maximum 0.5 A*
	* Maximum 1 mA current leakage	
	Fan Control	
	On/Off:	Relay contact rated at 250 VAC, maximum 3A
	3-Speed:	Relay contact rated at 250 VAC, maximum 3A
	Variable Fan Speed:	0-10 VDC, maximum 10mA
Mounting	DIN rail or surface (two brackets supplied with controller).	
Dimensions (H x W x D)	118 mm x 108 mm x 31 mm (standard terminals) 146 mm x 108 mm x 31 mm (separable terminals)	
Housing	Material:	ABS + polycarbonate, self-extinguishing UL94-VO
	Protection:	IP30 (IEC529)
Shipping Weight	0.3 kg	
CE Compliance	Directive 89/336/EEC: EN61000-6-3 (EN 50081-1), EN61000-6-1 (EN 50082-1) Directive 73/23/EEC EN 60730	

Factory-Set Parameters

Table 3: Factory-Set Parameters

Comfort Set Point Heating	20°C	+/-3 K Remote Set Point. See Note 2.
	-1 K	12-28°C Remote Set Point
Comfort Set Point Cooling	22°C	+/-3 K Remote Set Point. See Note 2.
	+1 K	12-28°C Remote Set Point
Prop. Band Heating	-2 K	-1 K when RED jumper OUT. See Note 1.
Integral Time Heating	4 minutes	Disabled when BLUE jumper OUT. See Note 1.
Standby Bias Heating	-2 K	
Night Bias Heating	-4 K	
Prop. Band Cooling	+2 K	+1 K when RED jumper OUT. See Note 1.
Integral Time Cooling	4 minutes	Disabled when BLUE jumper OUT. See Note 1.
Standby Bias Cooling	+2 K	
Night Bias Cooling	+4 K	
Heating Valve Stroke (PAT)	60 seconds	+/- 1% Dead Band
Heating Valve Cycle (DAT)	300 seconds	5% minimum On/Off
Heating Stage 1 Load (2St)	50 %	5% differential
Cooling Valve Stroke (PAT)	60 seconds	+/- 1% Dead Band
Cooling Valve Cycle (DAT)	300 seconds	5% minimum On/Off
Cooling Stage 1 Load (2St)	50 %	5% differential
Fan On/Off Differential	1 K	
Fan always On in Comfort	No	Yes = Fan On in zero energy band in Comfort.
Min. Fan Output (0-10 VDC)	50 %	
Low Limit Set Point	12°C	
Low Limit Differential	2 K	
Winter Compensation	Disabled	Requires Outdoor Air Temp via Bus when enabled.
Winter Set Point	10°C	
Winter Authority Slope	-0.1	
Winter Authority Limit	-3 K	
Summer Compensation	Disabled	Requires Outdoor Air Temp via Bus when enabled.
Summer Set Point	24°C	
Summer Authority Slope	0.2	
Summer Authority Limit	5 K	
Room Temp Filter Const.	10 seconds	
Remote Set Point Filter Const.	60 seconds	
Common Set Point	0°C	Valid range = -3 to 28. See Note 2.
Unit Mount Sensor	No	Yes = Hard wired temperature sensor is used and TM-9180 is connected.

Note 1: Controllers are delivered from the factory with the RED jumper “IN” and the BLUE jumper “OUT” unless otherwise specified.

Note 2: When the Remote Set Point is +/-3 K, the Common Set Point may be set to the desired mean room temperature (e.g. 21°C) and the Comfort Set Point Heating and Comfort Set Point Cooling set as biases of -1K and +1K, respectively.

Parameters for Supervisory System

The following table lists the parameters which are available for monitoring by Metasys supervisory systems. For details of configuration procedures and override possibilities, refer to the technical documentation of the system which is to be used.

Table 4: Supervisory System Parameters

Parameter Description	Units	Tag Name	Function
Room Temperature	°C	AI1	Read
Remote Set Point	°C or K	AI2	Read
Working Set Point Heating	°C	WSP1	Read
Working Set Point Cooling	°C	WSP2	Read
Control Output Heating	%	OCM1	Read
Control Output Cooling	%	OCM2*	Read
Heating/Cooling Mode	Cool/Heat	L1A*	Read
Operating Status	Comfort/Standby/Night/Off	MODS	Read
Alternate Mode	Off/On	ALT	Read
Window Contact	Closed/Open	WIN	Read
Occupancy Sensor	Occupied/Unoccupied	OCC	Read
Low Limit Mode	Off/On	AFM	Read
Winter Set Point Compensation	K	WAC	Read
Summer Set Point Compensation	K	SAC	Read
Requested Operating Mode	Comfort/Standby/Night/Off	MODC	Write
Set Outdoor Temperature	°C	XAI4	Read/Write
Set Common Set Point	°C or K	PM6K1	Read/Write
On/Off Fan Control:			
Fan Status	Off/On	DO2	Read
3-Speed Fan Control:			
Fan Speed 1	Off/On	DO5	Read
Fan Speed 2	Off/On	DO6	Read
Fan Speed 3	Off/On	DO7	Read
Fan Override	Auto/Hold	FOV	Read
Fan Speed Controller:			
Control Output Fan	%	OCM3	Read

*Note: For 0-10 VDC control signal outputs, OCM1 and OCM2 operate in parallel and indicate the output level in Heating or Cooling. Therefore, at the supervisory system, OCM1 should be monitored as the “Heating/Cooling Control Output” and L1A can be monitored to indicate whether the controller is in heating or cooling mode. (Requires Metasys Release 9.0 or later.)

Ordering Codes

Table 5: TC-9102 Controller Ordering Codes

Ordering Code	Hardware Configuration Code (used in EuroPRO)	Outputs		Set Point Range
TC-91a2-b220	TC-91x2-x220	2 x 0 to 10 VDC	0 to 10 VDC Fan Control	12 -28°C
TC-91a2-b225	TC-91x2-x220	2 x 0 to 10 VDC	0 to 10 VDC Fan Control	+/-3 K
TC-91a2-b440	TC-91x2-x330	2 x DAT	0 to 10 VDC Fan Control	12 -28°C
TC-91a2-b445	TC-91x2-x330	2 x DAT	0 to 10 VDC Fan Control	+/-3 K
TC-91a2-b550	TC-91x2-x330	2 x PAT	0 to 10 VDC Fan Control	12 -28°C
TC-91a2-b555	TC-91x2-x330	2 x PAT	0 to 10 VDC Fan Control	+/-3 K
TC-91a2-b660	TC-91x2-x330	2 x 2 Stage On/Off	0 to 10 VDC Fan Control	12 -28°C
TC-91a2-b665	TC-91x2-x330	2 x 2 Stage On/Off	0 to 10 VDC Fan Control	+/-3 K
TC-91a2-b221	TC-91x2-x221	2 x 0 to 10 VDC	On/Off Fan	12-28°C
TC-91a2-b226	TC-91x2-x221	2 x 0 to 10 VDC	On/Off Fan	+/-3 K
TC-91a2-b441	TC-91x2-x331	2 x DAT	On/Off Fan	12-28°C
TC-91a2-b446	TC-91x2-x331	2 x DAT	On/Off Fan	+/-3 K
TC-91a2-b551	TC-91x2-x331	2 x PAT	On/Off Fan	12-28°C
TC-91a2-b556	TC-91x2-x331	2 x PAT	On/Off Fan	+/-3 K
TC-91a2-b661	TC-91x2-x331	2 x 2 Stage On/Off	On/Off Fan	12-28°C
TC-91a2-b666	TC-91x2-x331	2 x 2 Stage On/Off	On/Off Fan	+/-3 K
TC-91a2-b222	TC-91x2-x222	2 x 0 to 10 VDC	3-Speed Fan	12-28°C
TC-91a2-b227	TC-91x2-x222	2 x 0 to 10 VDC	3-Speed Fan	+/-3 K
TC-91a2-b442	TC-91x2-x332	2 x DAT	3-Speed Fan	12-28°C
TC-91a2-b447	TC-91x2-x332	2 x DAT	3-Speed Fan	+/-3 K
TC-91a2-b552	TC-91x2-x332	2 x PAT	3-Speed Fan	12-28°C
TC-91a2-b557	TC-91x2-x332	2 x PAT	3-Speed Fan	+/-3 K
TC-91a2-b662	TC-91x2-x332	2 x 2 Stage On/Off	3-Speed Fan	12-28°C
TC-91a2-b667	TC-91x2-x332	2 x 2 Stage On/Off	3-Speed Fan	+/-3 K
Controller for remote set point: a = 0, with integral set point: a = 1				
Controller with standard terminals: b = 0, with separable terminals: b = 1				

- Notes:
- Ordering codes must be used in orders to the Lomagna factory.
 - The Hardware Configuration Code is shown in the EuroPRO Configuration Tool to indicate the basic hardware configuration of the controller which is being commissioned. The software configuration of the controller, as indicated by the Ordering Code, may be changed in EuroPRO to any other software configuration with the same hardware configuration. For example, TC-91a2-b442 could be changed to TC-91a2-b552 because both have the same hardware configuration, TC-91x2-x332.
 - Modules with PWM control signal outputs have been discontinued. Contact your local Johnson Controls office for details of replacement controllers.

Table 6: Room Command Module Ordering Codes

Ordering Code	Description			
TM-1140-0000	w/o Occupancy Button	NTC Sensor	w/o S.P. dial	
TM-1150-0000	Occupancy Button	NTC Sensor	w/o S.P. dial	
TM-1160-0000	Occupancy Button	NTC Sensor	12-28°C	
TM-1160-0005	Occupancy Button	NTC Sensor	+/- 3 K	
TM-1160-0002	Occupancy Button	NTC Sensor	12-28°C	3-Speed Fan Override
TM-1160-0007	Occupancy Button	NTC Sensor	+/- 3 K	3-Speed Fan Override
TM-1170-0000	Occupancy Button	w/o NTC Sensor	12-28°C	
TM-1170-0005	Occupancy Button	w/o NTC Sensor	+/- 3 K	
TM-1170-0002	Occupancy Button	w/o NTC Sensor	12-28°C	3-Speed Fan Override
TM-1170-0007	Occupancy Button	w/o NTC Sensor	+/- 3 K	3-Speed Fan Override
TM-1190-0000	w/o Occupancy Button	NTC Sensor	12-28°C	
TM-1190-0005	w/o Occupancy Button	NTC Sensor	+/- 3 K	
TM-9180-0210	LCD Display/Keyboard	with View Mode and Programming Mode, off-white enclosure		
TM-9180-0210W	LCD Display/Keyboard	with View Mode and Programming Mode, white enclosure		

Table 7: Software and Accessories Ordering Codes

Ordering Code	Description
TE-9100-8501	Unit Mount NTC Temperature Sensor (1.5-m cable)
TC-9100-TOOL	Commissioning Software for DOS (3.5" diskette)
MW-MTOOLE-0	Configuration Software for Windows® (CD)
MW-MTOOLE-6	Configuration Software for Windows® (CD)



Johnson Controls International, Inc.

Headquarters:

Milwaukee, Wisconsin, USA

European Distribution Centre:

Westendhof 3, D-45143 Essen, Germany

European Factories:

Essen (Germany) and Lomagna (Italy)

Branch Offices

Principal European Cities.

Issued in Europe