



# techsystem

automatyka klimatyzacja wentylacja

▸ zapoznaj się z naszą ofertą

## TM-1100 Series Room Command Module

The TM-1100 series of Room Command Modules are designed for use with the TC-9102, TC-9109 and TCU series of DDC terminal unit controllers. The set point dial enables the room occupant to adjust the working set point of the controller within the range of 12...28°C or -3 K to +3 K, according to the model number. The occupancy button enables the occupant to switch the mode of operation of the controller between COMFORT and STANDBY or to request a temporary COMFORT mode during NIGHT operation. An LED indicator shows the current operating mode.

For TC-9102 and TCU Fan Coil Unit controllers, a Room Command Module with a 3-speed fan override adjuster is available, and models without a temperature sensor are provided for application where the room temperature sensor is mounted inside the Fan Coil Unit.



**TM-1140-0000**



**TM-1150-0000**



**TM-1190-0005**



**TM-1160-0000**



**TM-1160-0007**

### Features and Benefits

- |  |  |
|--|--|
| <input type="checkbox"/> <b>Modern and attractive cover which snaps onto a plug-in mounting base</b> | Blends in with room decor.<br>Easy installation.                     |
| <input type="checkbox"/> <b>Terminals located on mounting base.</b>                                  | Easy wiring and commissioning.                                       |
| <input type="checkbox"/> <b>All models available with or without Occupancy override button</b>       | Covers a large number of applications in public buildings and hotels |

## Application Overview

### Set Point Dial

The Room Command Module is available with a set point dial marked 12...28°C or ±. The module must be connected to a TC-9102/9 TCU series controller with the corresponding remote set point range. The 12...28°C range module determines the set point of the controller while the ± range module gives a deviation to the room temperature set point programmed into the controller. Refer to Ordering Codes at the end of this document.

### Occupancy Button

When pressed for approximately one second, the occupancy button changes the mode of operation of the controller to the “alternate” mode or back to normal mode. When the controller is in COMFORT (occupied) mode the alternate mode is STANDBY (and vice versa), and when in NIGHT (unoccupied) mode the alternate mode is a temporary COMFORT (bypass) mode for a period of one hour. Full details of the alternate modes can be found in the *TC-9102 Technical Bulletin (Ordering Code MN-9100-2117)* of the *System 91 Manual* or *TCU Technical Bulletin (Ordering Code MN-LCC-01)* in *LonWorks Compatible Controllers Manual*.

### Mode Indicator

The LED indicator directly next to the Occupancy Button shows the current operating mode of the controller as follows:

Steady On: COMFORT Mode (occupied)

Flashing: STANDBY Mode

Off: NIGHT (unoccupied) or OFF Mode

### 3-Speed Fan Override Adjuster

When connected to a TC-9102 Controller which has a 3-speed fan control auxiliary output, the 3-speed fan override adjuster allows manual control of the speed of the fan. The positions of the adjuster are as follows:

AUTO Automatic fan speed is set by the TC-9102 or TCU Controller.

OFF Fan OFF

I Fan low speed

II Fan medium speed

III Fan high speed

The fan speed adjuster is only active when the controller is in COMFORT mode. In Low Limit mode the fan always runs at high speed.

## Ordering Data

Item Code	Fan Speed Override	Occupancy Button	Temperature Setpoint Dial Scale	Built-in Sensor	Dimensions
TM-1140-0000	-	-	-	NTC K2	See Fig 8
TM-1150-0000	-	Yes	-	NTC K2	See Fig 9
TM-1160-0000	-	Yes	12...28 °C	NTC K2	See Fig 12
TM-1160-0005	-	Yes	±	NTC K2	See Fig 12
TM-1160-0002	3-speed fan override	Yes	12...28 °C	NTC K2	See Fig 11
TM-1160-0007	3-speed fan override	Yes	±	NTC K2	See Fig 11
TM-1170-0005	-	Yes	±	-	See Fig 12
TM-1170-0007	3-speed fan override	Yes	±	-	See Fig 11
TM-1190-0000	-	-	12...28 °C	NTC K2	See Fig 13
TM-1190-0005	-	-	±	NTC K2	See Fig 10

**Table 1: Room Command Module Ordering Codes**

Ordering Code	Description
TM-1100-8931	Plastic Surface Mounting Base - White
TE-9100-8501	Unit Mount NTC Temperature Sensor (1.5-m cable)
TM-9100-8900	Special tool for opening enclosure

**Table 2: Accessories Ordering Codes**

### Installation

The TM-1100 Series Room Command Module is designed for wall mounting in the room to be controlled. It should be located where the occupant can easily read and adjust the set point and fan speed override. If the module has an NTC temperature sensor, it should be placed where the temperature is representative of the general room conditions. Cold or warm air draughts, radiant heat and direct sunlight should be avoided.

The installation of electrical wiring must conform to local codes and should be carried out by authorized personnel only. Users should ensure that all Johnson Controls products are used safely and without risk to health or property.

### Mounting

Remove the base of the module from the cover by inserting the point of the special TM tool (Ordering Code TM-9100-8900) into the small hole at the center top of the cover. While pressing down gently, prise the base away from the cover. As the two parts separate, remove the tool and continue to pull the cover away from the base until the cover is free. To reassemble the room command module, place the cover over the lower edge of the base and push the upper part of the cover until it "clicks" firmly in place.

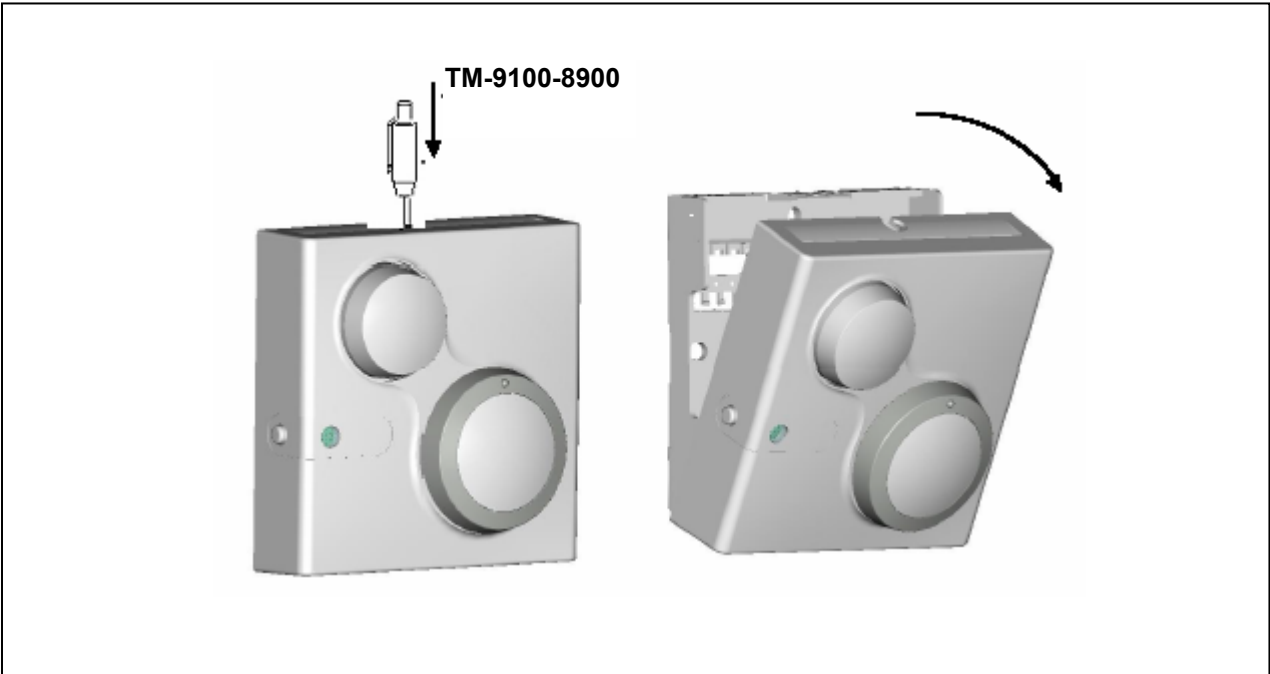

**Figure 1: Removing Cover from Base**

### Direct Surface Mounting

For direct surface mounting:

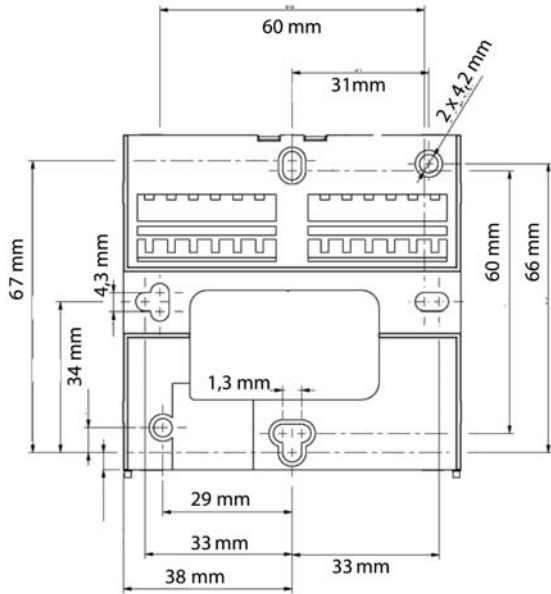
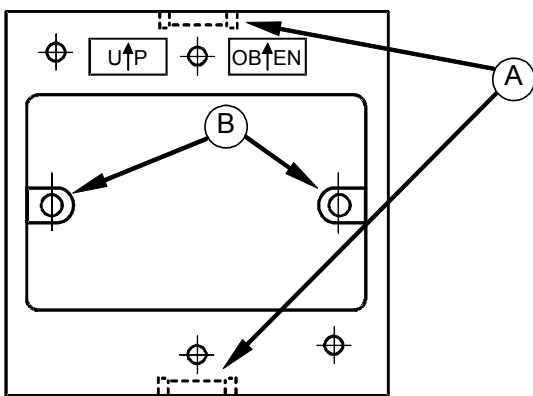

**Figure 2: Module Base (Dimensions in mm)**

1. Mount the module base on the wall to cover the electrical outlet and secure with at least two screws.

### Surface Mounting with Mounting Kit (TM-1100-8931)

To install the surface mounting base (for dimensions, see Figure):



1. Remove one of the notches (A) with a suitable tool.

2. Mark the position of the holes (B) on the wall and drill holes 5 mm in diameter. Insert plastic plugs into holes.

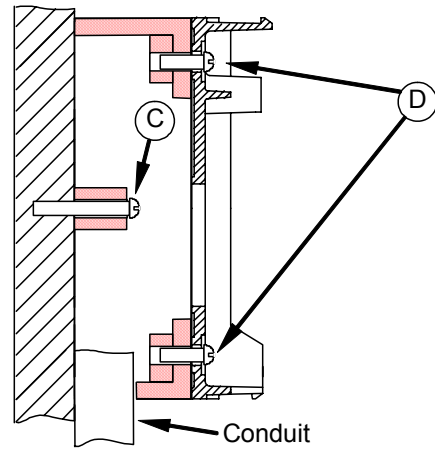

3. Position and fix the mounting base to the wall using the two long screws (C) provided in the kit.

4. Fix the base of the TM-1100 to the mounting base using the two short screws (D) provided in the kit.

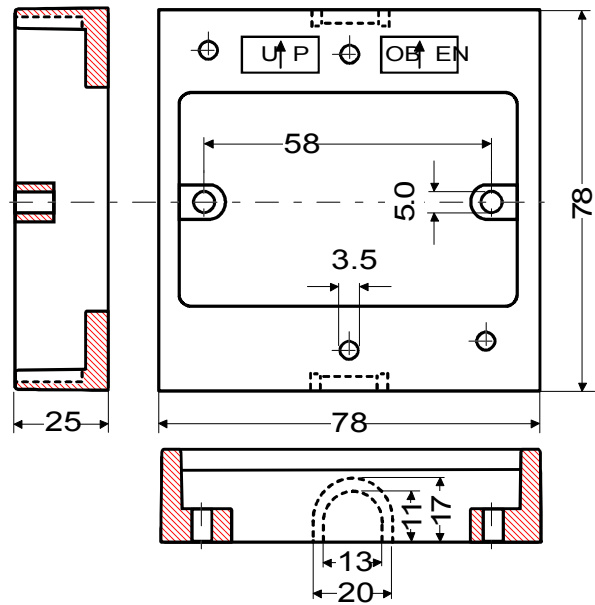

**Figure 3: Surface Mounting Base (Dimensions in mm)**

## Wiring

Before connecting or disconnecting any wires, ensure that all power supplies have been switched off and all wires are potential-free to prevent equipment damage and avoid electrical shock. Terminations are made on the terminal blocks in the base of the module, which accept up to 1.5 mm<sup>2</sup>

wires. Follow the wiring diagrams shown in the figures below. All wiring to the module is at extra low (safe) voltage and must be separated from power line voltage wiring. Do not run wiring close to transformers or high frequency generating equipment. Complete and verify all wiring connections before applying power to the controller to which the module is connected.

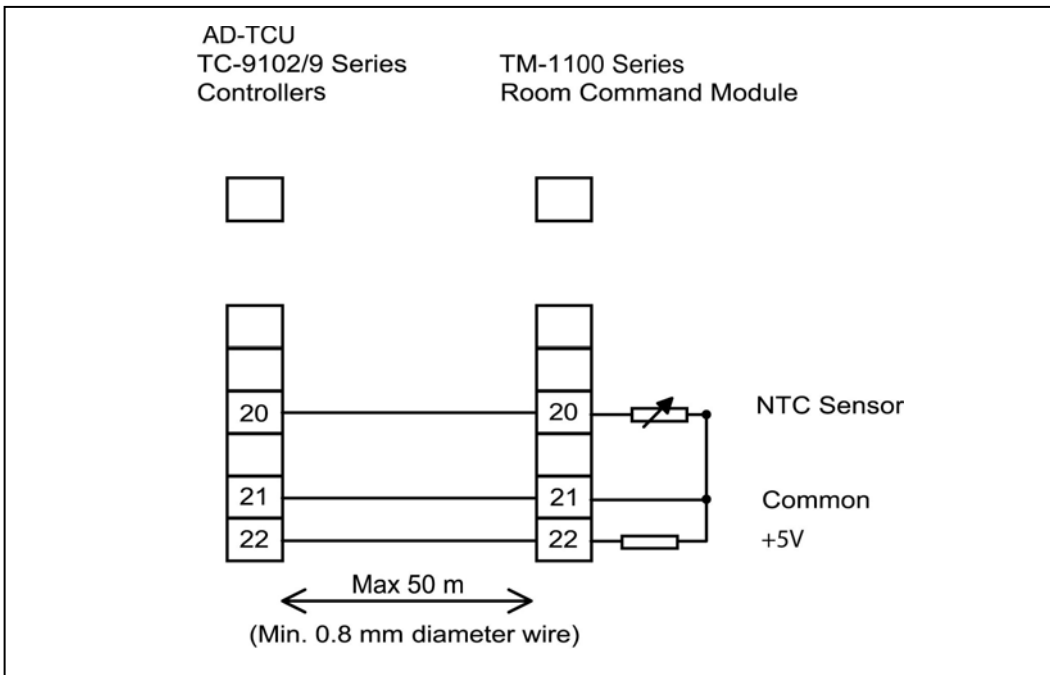

Figure 4: TM-1140-0000

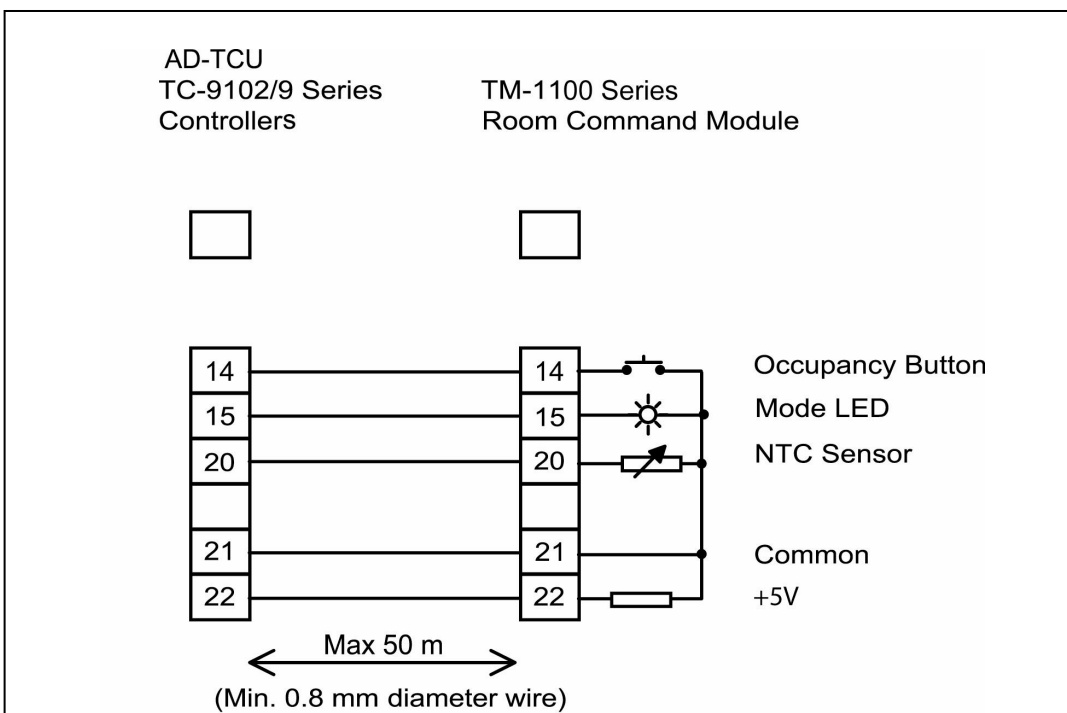
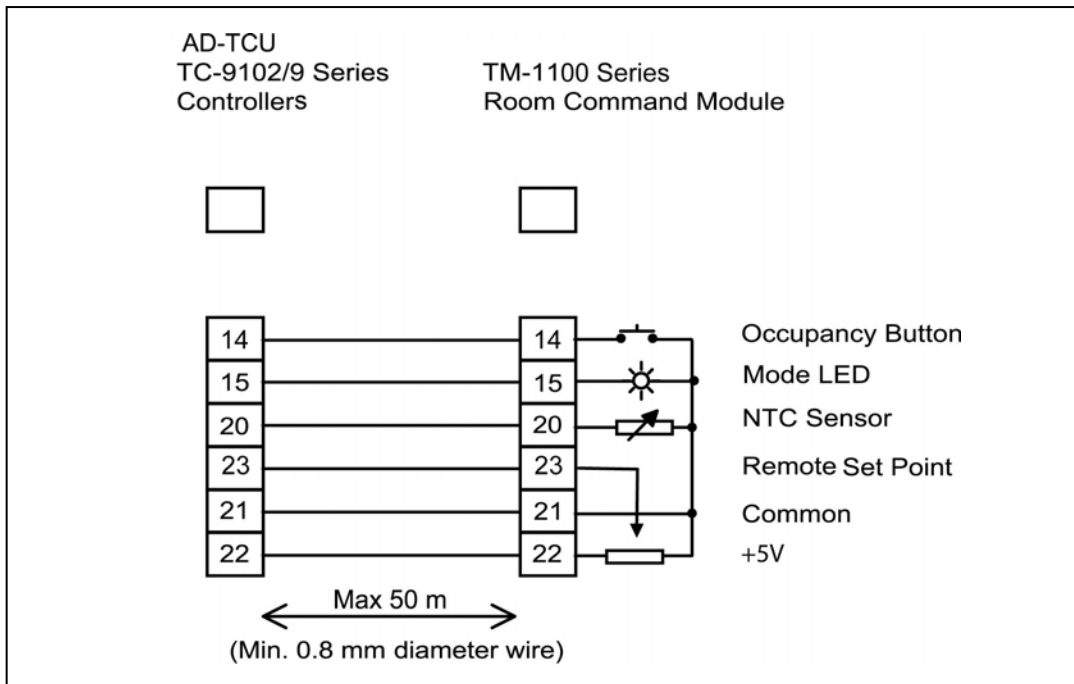
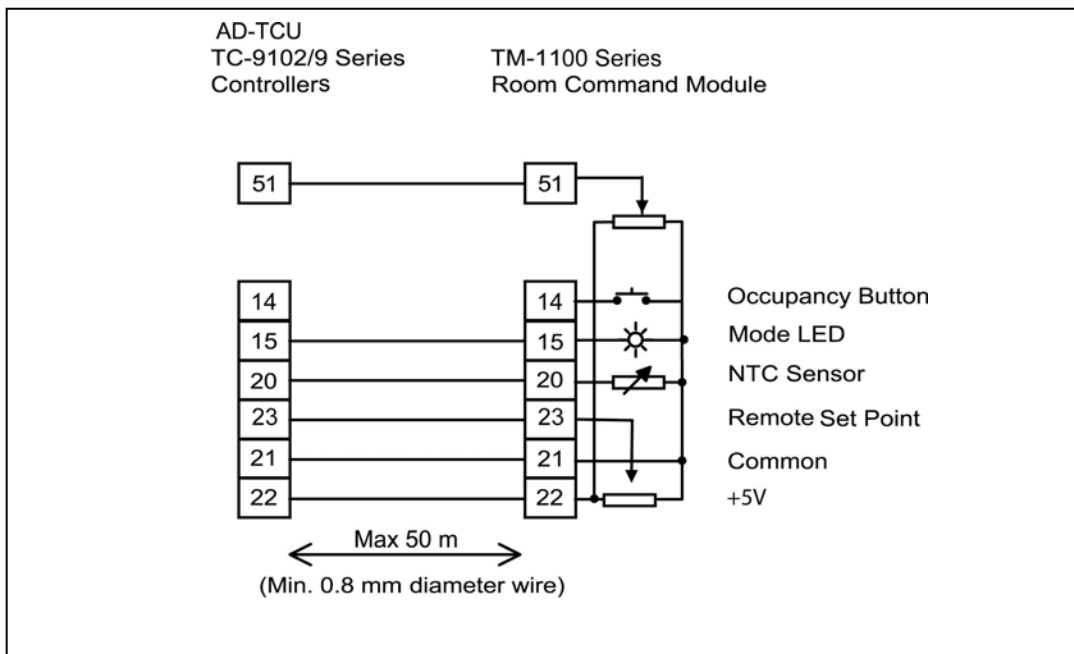

Figure 5: TM-1150-0000



**Figure 6: TM-1160-0000 and TM-1160-0005**



**Figure 7: TM-1160-0002 and TM-1160-0007**

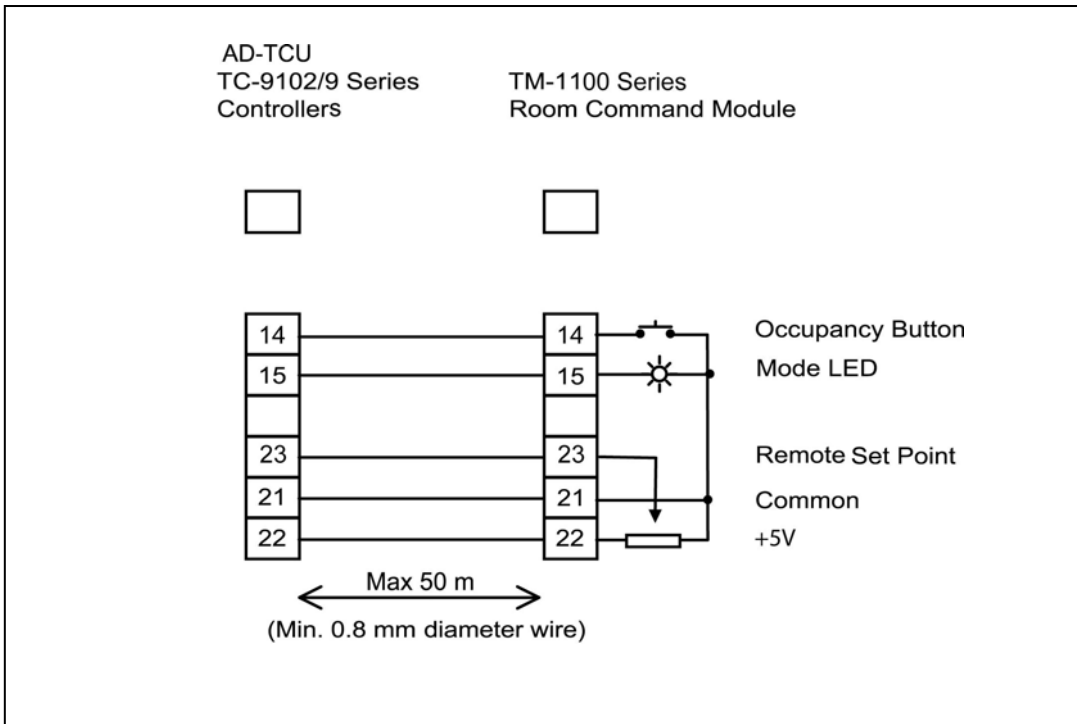

Figure 8: TM-1170-0005

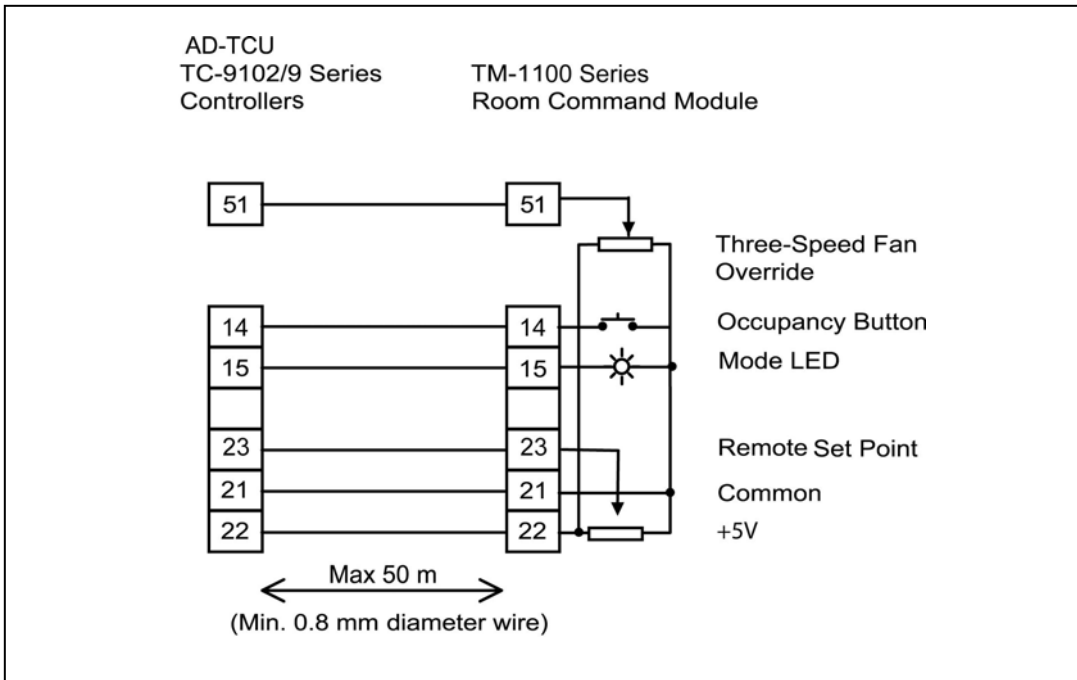
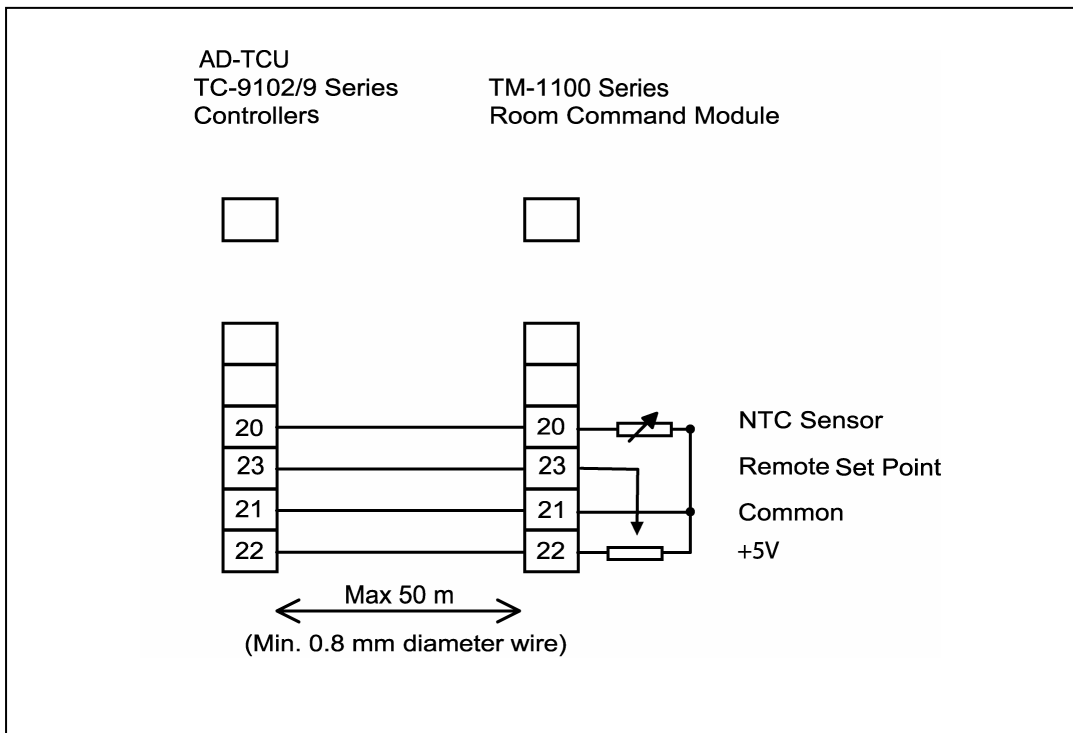

Figure 9: TM-1170-0007



**Figure 10: TM-1190-0000 and TM-1190-0005**

## Dimensions

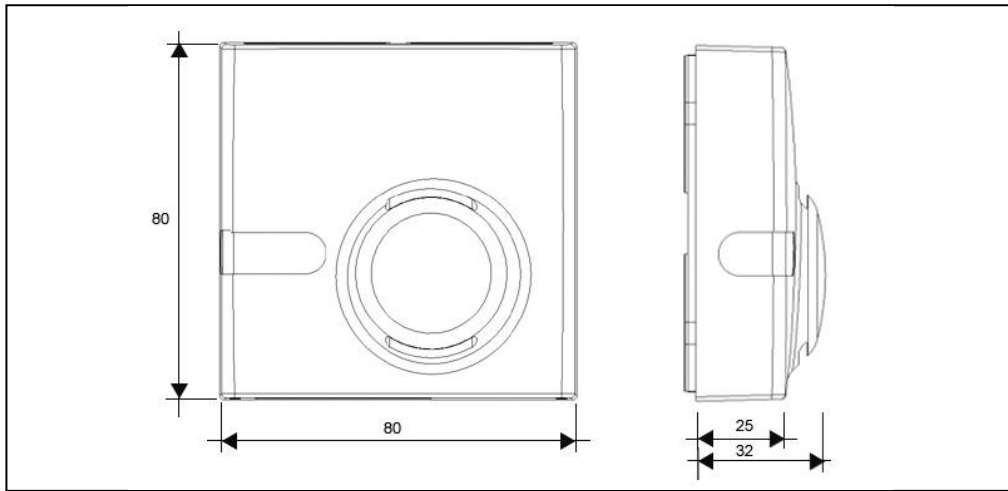

Figure 11: TM-1140-0000

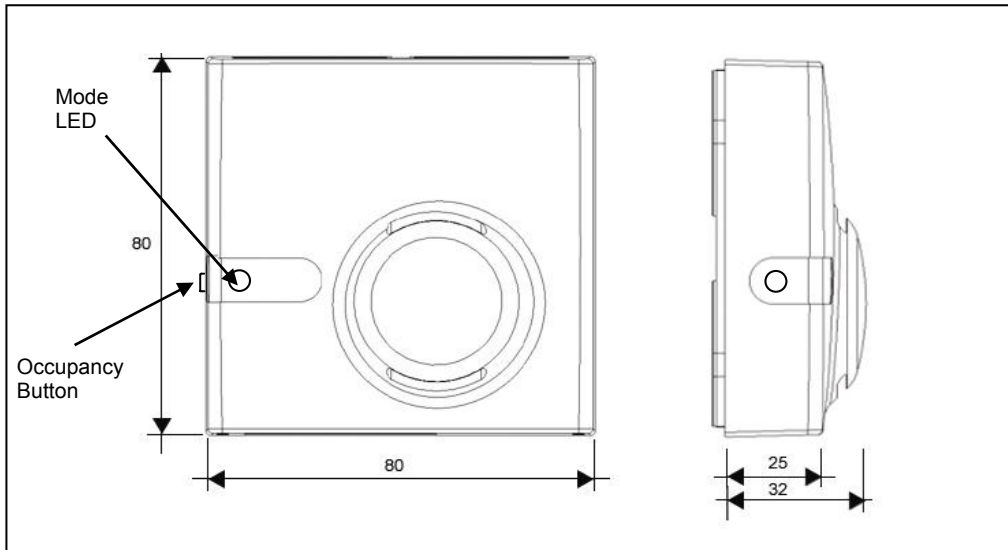

Figure 12: TM-1150-0000

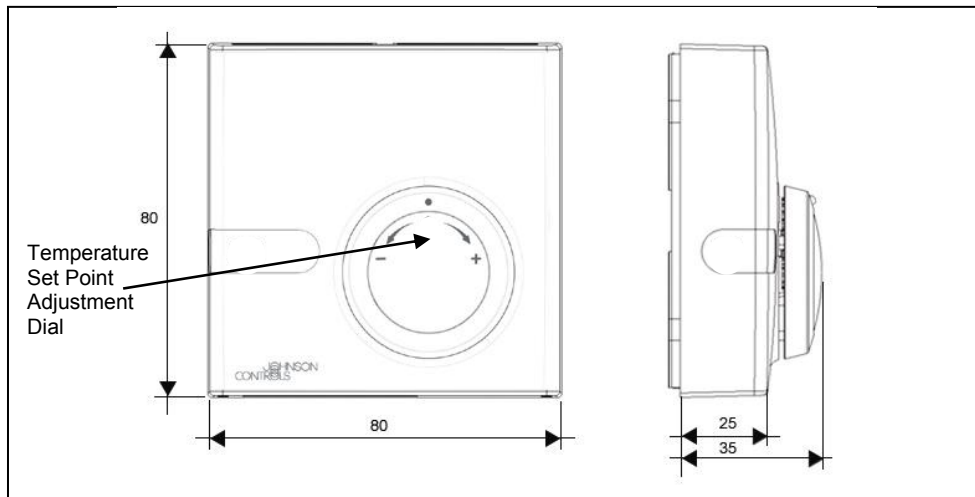
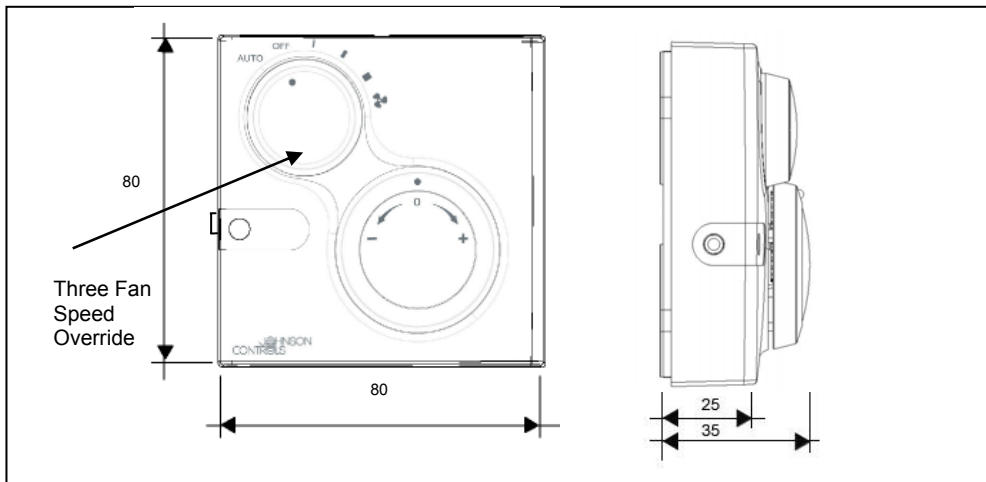
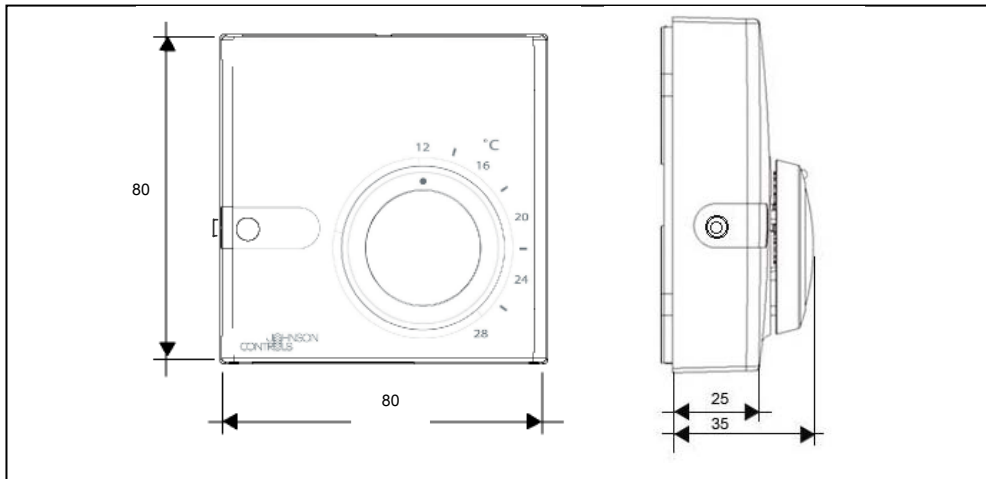

Figure 13: TM-1190-0005



**Figure 14: TM-1160-0007 and TM-1170-0007**



**Figure 15: TM-1160-0000**

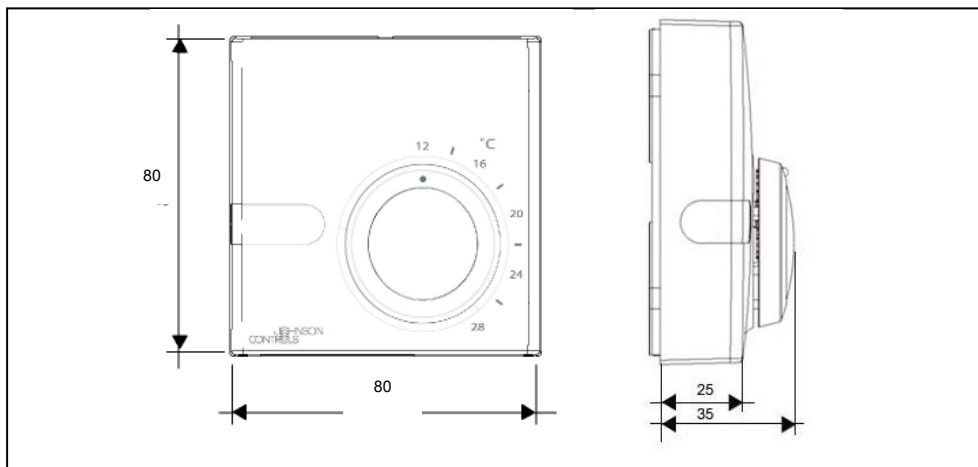

**Figure 16: TM-1190-0000**

## Specifications

<b>Supply Voltage</b>	Power from TC-9102, TC-9109 or TCU Series Controller	
<b>Ambient Operating Conditions</b>	0 to 50°C 10 to 90% RH non condensing	
<b>Ambient Storage Conditions</b>	-20 to 70°C 10 to 90% RH non condensing	
<b>Terminations</b>	Terminal block in base for 1 x 1.5 mm <sup>2</sup> (maximum) cable.	
<b>Temperature Sensor</b>	NTC Thermistor 0 to 40°C, 2252 ohm at 25°C.	
<b>Remote Set Point</b>	10 kOhm potentiometer marked for 12°C to 28°C or ± (range ±3 K )	
<b>3-Speed Fan Override</b>	10 kOhm potentiometer with mechanically guided positions for Auto, Off, I (low speed), II (medium speed) and III (high speed).	
<b>Occupancy Button</b>	Momentary contact (switches 5V at 1 mA).	
<b>Mode Indicator</b>	Green LED (5V, 4 mA)	
<b>Mounting</b>	Direct surface mount, plastic base for surface mount with wiring conduits (See Ordering Codes.)	
<b>Materials</b>	Enclosure	ABS+PC; self extinguishing HB UL 94
	Base	
	Occupancy Override Button	
	Fan Speed Override Dial	
	Setpoint Dial	
<b>Colors</b>	Enclosure	RAL9016 (GE86280 )
	Base	
	Occupancy Override Button	
	Fan Speed Override Dial	
	Setpoint Dial	RAL7047 (GE GY81118)
<b>Protection Class</b>	Enclosure	IP30 (EN 60529)
<b>Dimensions (H x W xS)</b>	TM-1140-0000 TM-1150-0000	80 mm x 80 mm x 32 mm
	TM-1160-000x TM-1170-000x TM-1190-000x	80 mm x 80 mm x 35 mm
<b>Shipping Weight</b>	0.15 kg	
<b>CE Conformity</b>	EMC Directive 89/336/EEC	EN-61000-6-3 EN-61000-6-2

The performance specifications are nominal and conform to acceptable industry standards. For application at conditions beyond these specifications, consult the local Johnson Controls office. Johnson Controls, Inc. shall not be liable for damages resulting from misapplication or misuse of its products.



Johnson Controls International, Inc.

Headquarters:  
European Distribution Centre:  
European Factories:  
Branch Offices

Milwaukee, Wisconsin, USA  
Westendhof 3, D-45143 Essen, Germany  
Essen (Germany), Leeuwarden (The Netherlands) and Lomagna (Italy)  
Principal European Cities.