



techsystem

automatyka klimatyzacja wentylacja

▸ zapoznaj się z naszą ofertą

TM-2100 Series Room Command Module

Product Bulletin

Code No. 21.144 E Rev. B
Issued 02 2007

The TM-2100 series of Room Command Modules are designed for use with the FCC series of DDC terminal unit controllers. It's also suitable for use with Facility Explorer series of field controllers.

The set point dial enables the room occupant to adjust the working set point of the controller within the range of 12 to 28 °C or +/- according to the model number.

The occupancy button enables the occupant to request a "temporary occupied" (bypass) mode during "unoccupied" (night/weekend) operation. The "occupied" (comfort) mode is shown by an LED indicator.

The Room Command module with a three-speed fan override switch is also available.

'05 INDUSTRIAL DESIGN EXCELLENCE AWARDS



TM-2140-0000



TM-2150-0000



TM-2190-0000



TM-2160-0000



TM-2160-0002



TM-2190-0005



TM-2160-0005



TM-2160-0007

Figure 1: TM-2100 Series Room Command Module

Table 1: Features and Benefits

Features	Benefits
Modern and attractive cover with mounting base	Blends in with room decor. Easy installation.
Terminals located on mounting base.	Easy wiring and commissioning.
Models available with Occupancy override button, fan speed override and/or setpoint dial	Covers a large number of applications in public and private buildings, offices and hotels.

Application Overview

Set Point Dial

The Room Command Module is available with a set point dial marked 12...28 °C or ±. The module must be connected to the controller configured with the corresponding remote set point range. The 12...28 °C range module determines the set point of the controller while the ± range module gives a deviation to the room temperature set point programmed into the controller.

Occupancy Button

When pressed for approximately one second, the occupancy button changes the mode of operation of the controller to "temporary occupied" (bypass) for a period of time as configured in the controller when in "unoccupied" mode.

This enables the occupant to request comfort condition at night or at the weekend when the building is normally unoccupied.

Mode Indicator

The LED indicator directly next to the Occupancy Button shows the current operating mode of the controller as follows:

- Steady On** occupied (comfort) or temporary occupied (bypass) mode
- Off** unoccupied (night)

3-Speed Fan Override

The 3-speed fan override switch allows manual control of the speed of the fan. The positions of the switch are as follows:

- AUTO** Automatic operating. Fan speed is set by the controller.
- OFF** Fan OFF
- I** Fan low speed
- II** Fan medium speed
- III** Fan high speed

The fan speed override is only active when the controller is in occupied mode. When a low space temperature has been detected the fan runs at high speed with full heating.

Table 2: Ordering Data: Room Command Module Ordering Codes

Item Code	Fan Speed Override	Occupancy Button	Temperature Setpoint Dial Scale	Built-in Sensor
TM-2140-0000	-	-	-	NTC K10
TM-2150-0000	-	Yes	-	
TM-2160-0000	-	Yes	12...28 °C	
TM-2160-0005	-	Yes	±	
TM-2160-0002	3-speed fan override	Yes	12...28 °C	
TM-2160-0007	3-speed fan override	Yes	±	
TM-2190-0000	-	-	12...28 °C	
TM-2190-0002	3-speed fan override	-	12...28 °C	
TM-2190-0005	-	-	±	
TM-2190-0007	3-speed fan override	-	±	

Table 3: Accessories Ordering Codes

Ordering Codes	Description
TM-1100-8931	Plastic Surface Mounting Base - White
TE-9100-8502	Unit Mount NTC K10 Temperature Sensor (1.5-m cable)
TM-9100-8900	Special tool for enclosure opening

Installation

The TM-2100 Series Room Command Module is designed for wall mounting in the room to be controlled. It should be located where the occupant can easily read and adjust the set point dial or fan speed override switch. It should be placed where the temperature is representative of the general room conditions. Cold or warm air draughts, radiant heat and direct sunlight should be avoided.

The installation of electrical wiring must conform to local codes and must be carried out by authorized personnel only. Users must ensure that all Johnson Controls products are used safely and without risk to health or property.

Mounting

Remove the base of the module from the cover by inserting the point of the special TM tool (Ordering Code TM-9100-8900) into the small hole at the center top of the cover. While pressing down gently, prise the base away from the cover. As the two parts separate, remove the tool and continue to pull the cover away from the base until the cover is free.

To reassemble the room command module, place the cover over the lower edge of the base and push the upper part of the cover until it "clicks" firmly in place.

Mount the base on the wall to cover the electrical output and secure with at least two screws.

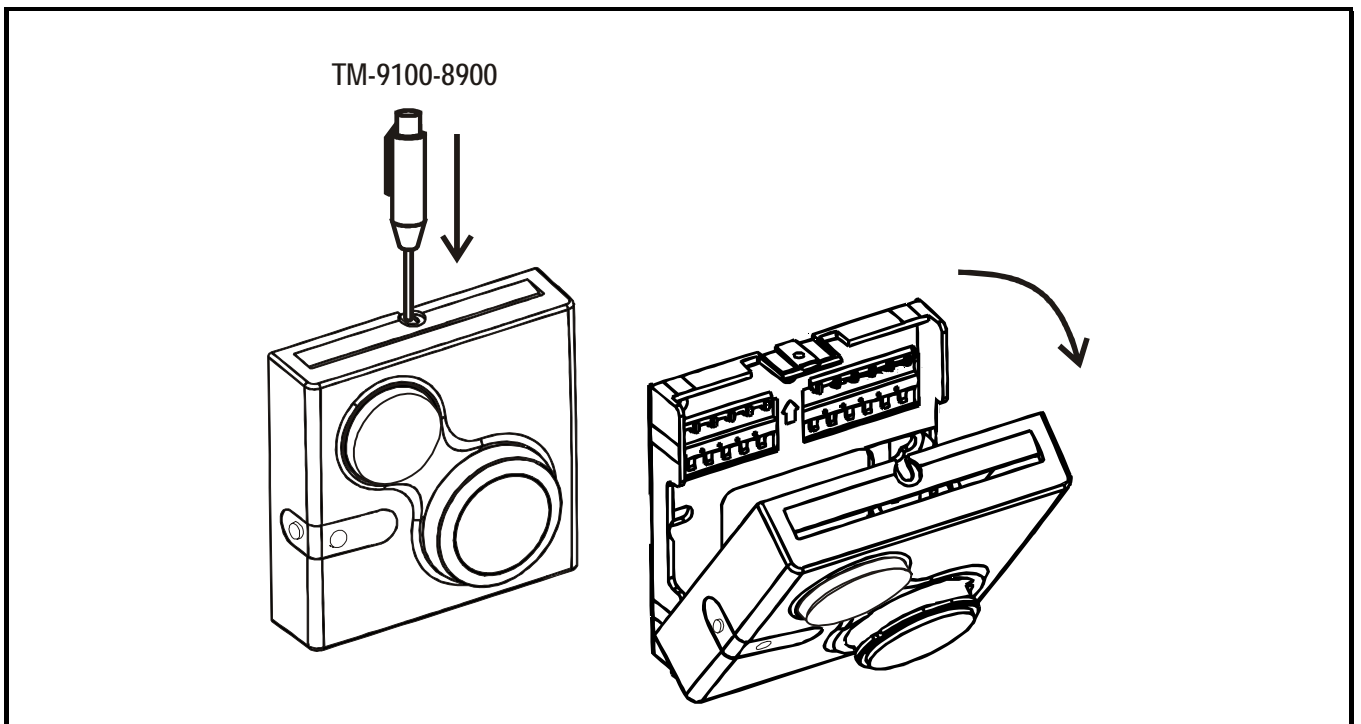

Figure 2: Room Command Module

Direct Surface Mounting over Electrical Outlet

For direct surface mounting:

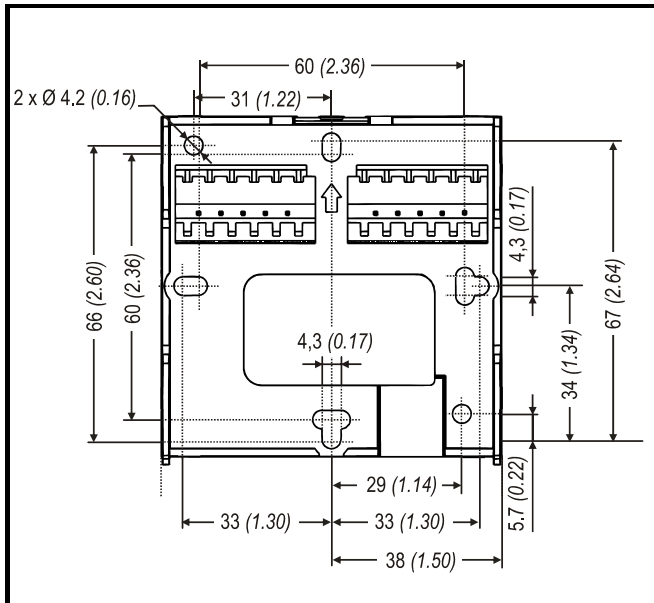

Figure 3: Module Base - Dimensions in mm (inches)

Mount the module base on the wall to cover the electrical outlet and secure with at least two screws.

Surface Mounting with Mounting Kit and Conduit

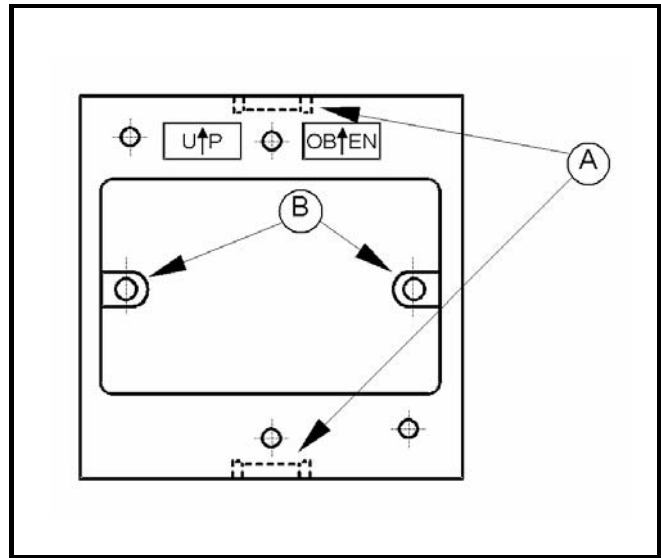

Figure 4: Mounting kit

1. Remove one of the notches (A) with a suitable tool for the conduit entry.
2. Mark the position of the holes (B) on the wall and drill holes 5 mm in diameter. Insert plastic plugs into holes.

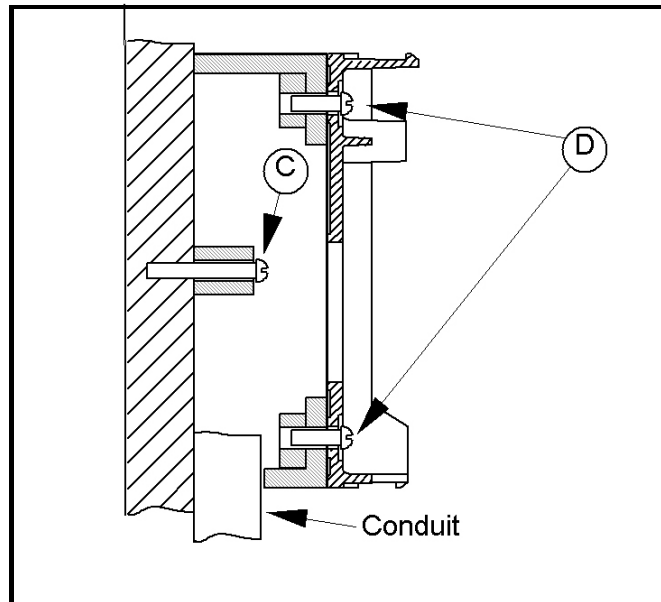

Figure 5: Mounting kit

3. Position and fix the mounting base to the wall using the two long screws (C) provided in the kit.

- Fix the base of the TM-2100 to the mounting base using the two short screws (D) provided in the kit.

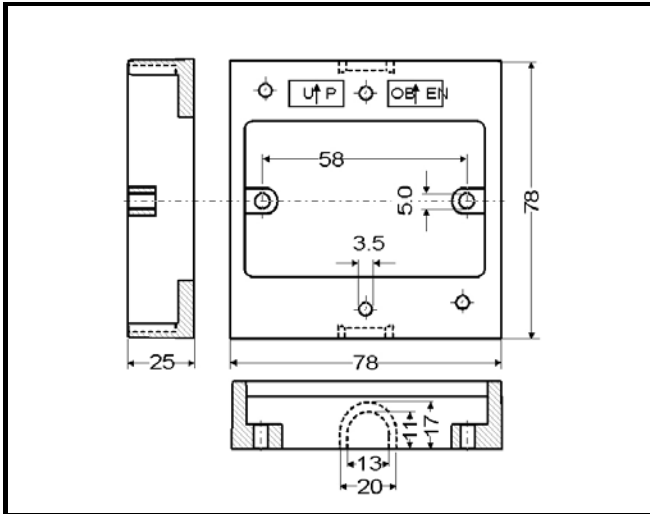

Figure 6: Surface Mounting base (Dimensions in mm)

Wiring

Before connecting or disconnecting any wires, ensure that all power supplies have been switched off and all wires are potential-free to prevent equipment damage and avoid electrical shock. Terminations are made on the terminal blocks in the base of the module, which accept up to 1.5 mm² wires.

Follow the wiring diagrams shown in the figures below. All wiring to the module is at extra low (safe) voltage and must be separated from power line voltage wiring. Do not run wiring close to transformers or high frequency generating equipment. Complete and verify all wiring connections before applying power to the controller to which the module is connected.

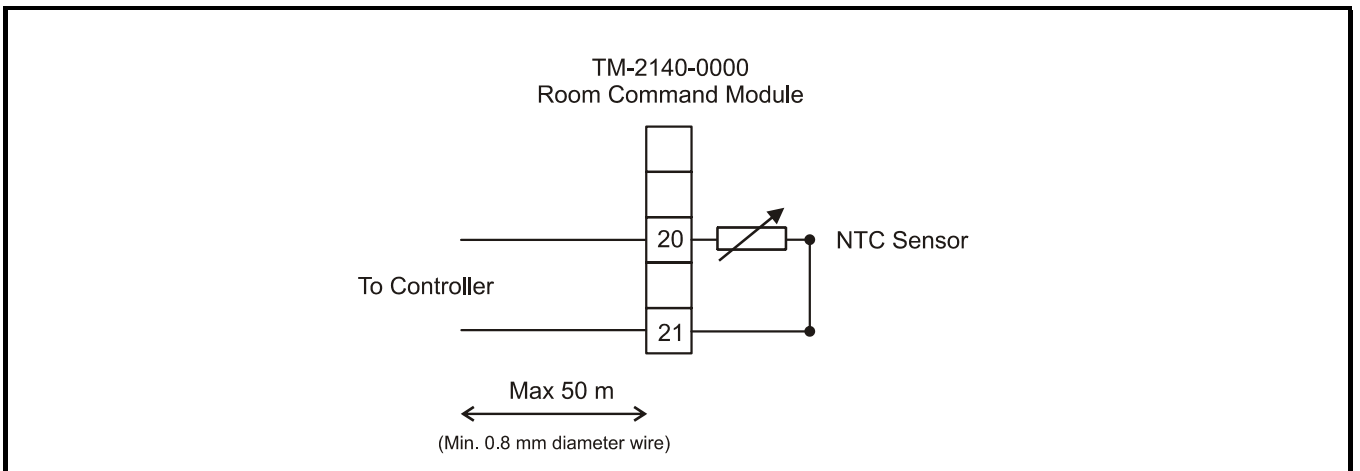

Figure 7: TM-2140-0000

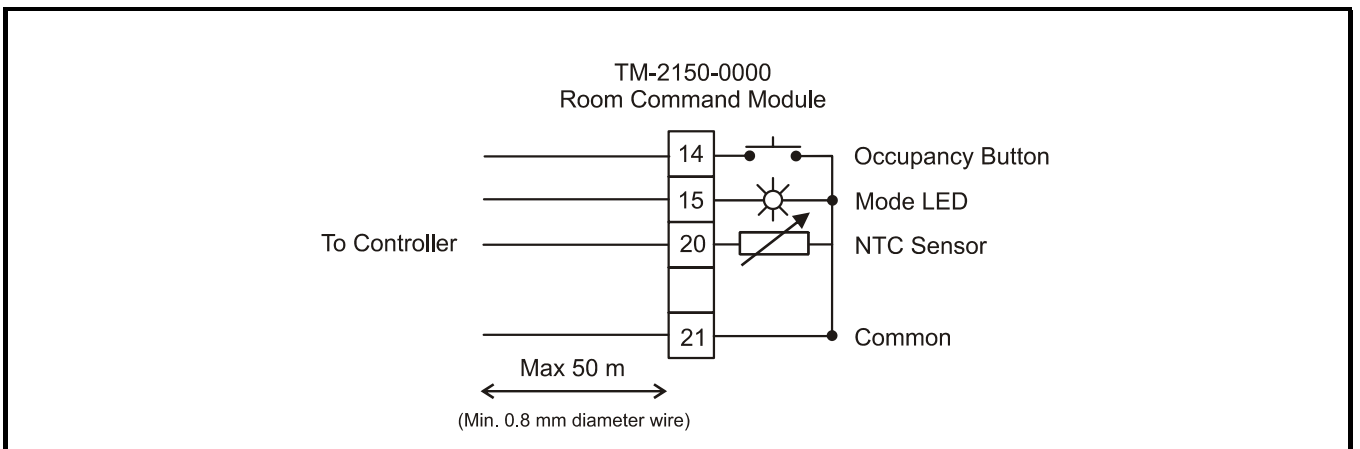

Figure 8: TM-2150-0000

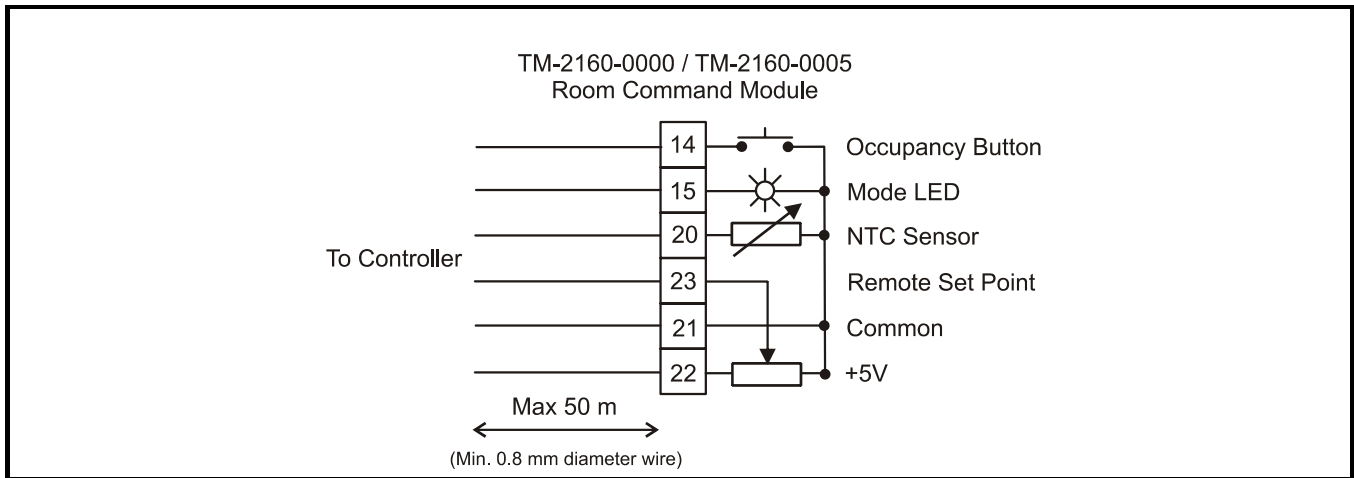

Figure 9: TM-2160-0000 and TM-2160-0005

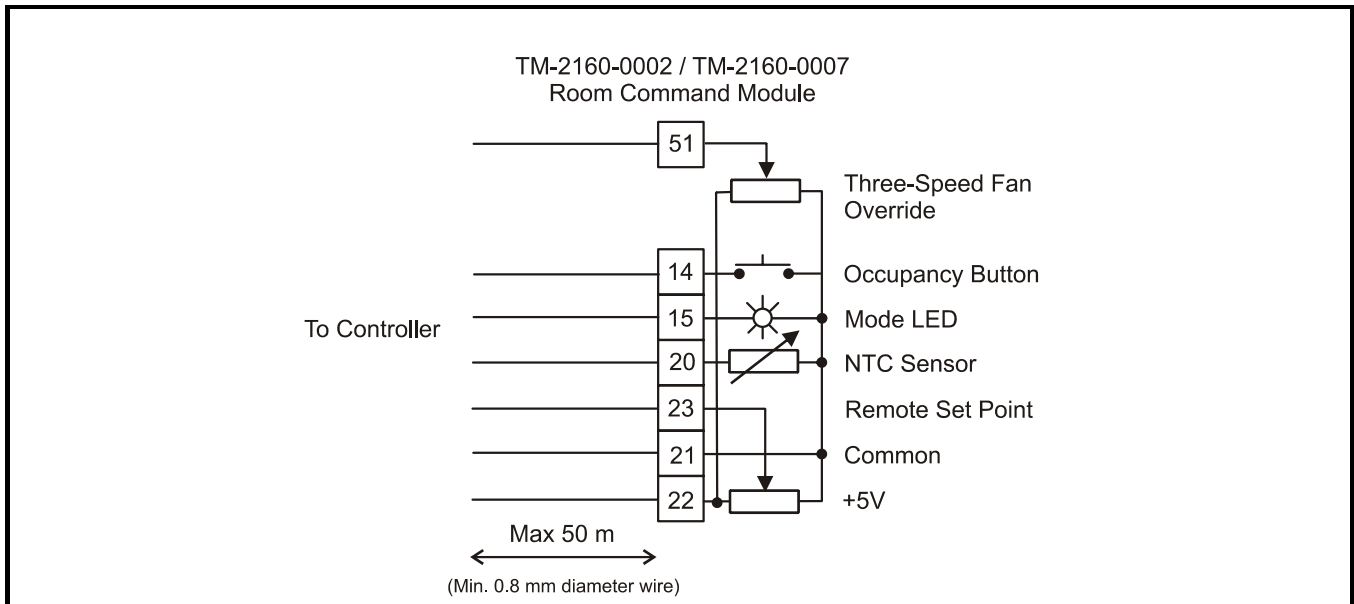

Figure 10: TM-2160-0002 and TM-2160-0007

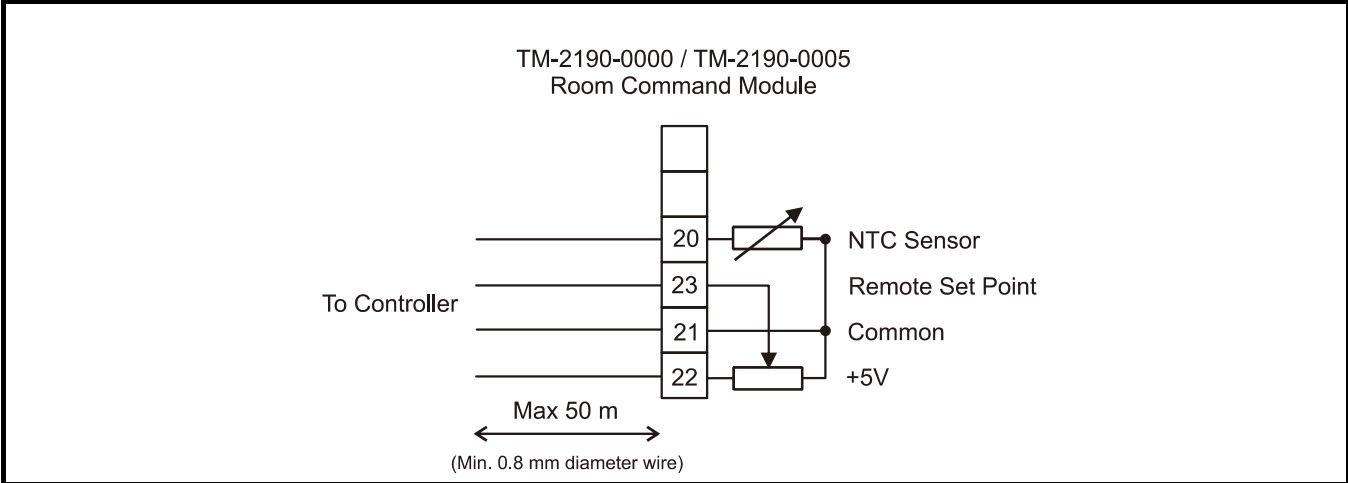

Figure 11: TM-2190-0000 and TM-2190-0005

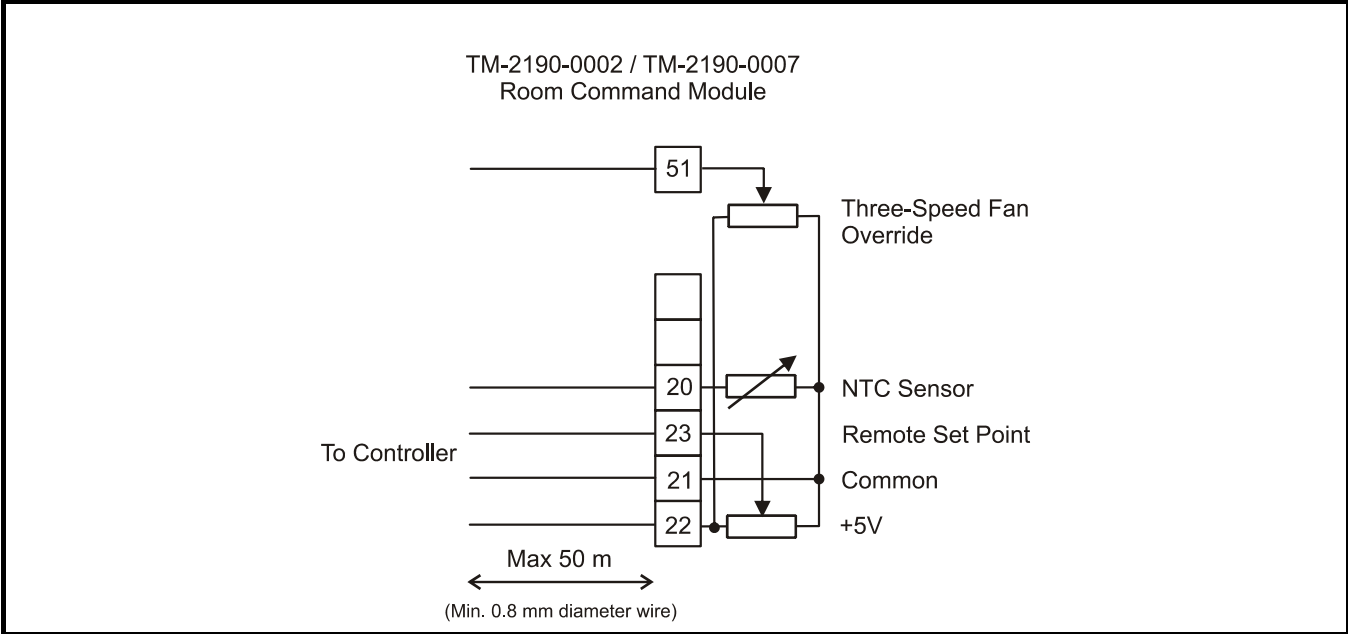

Figure 12: TM-2190-0002 and TM-2190-0007

Dimensions

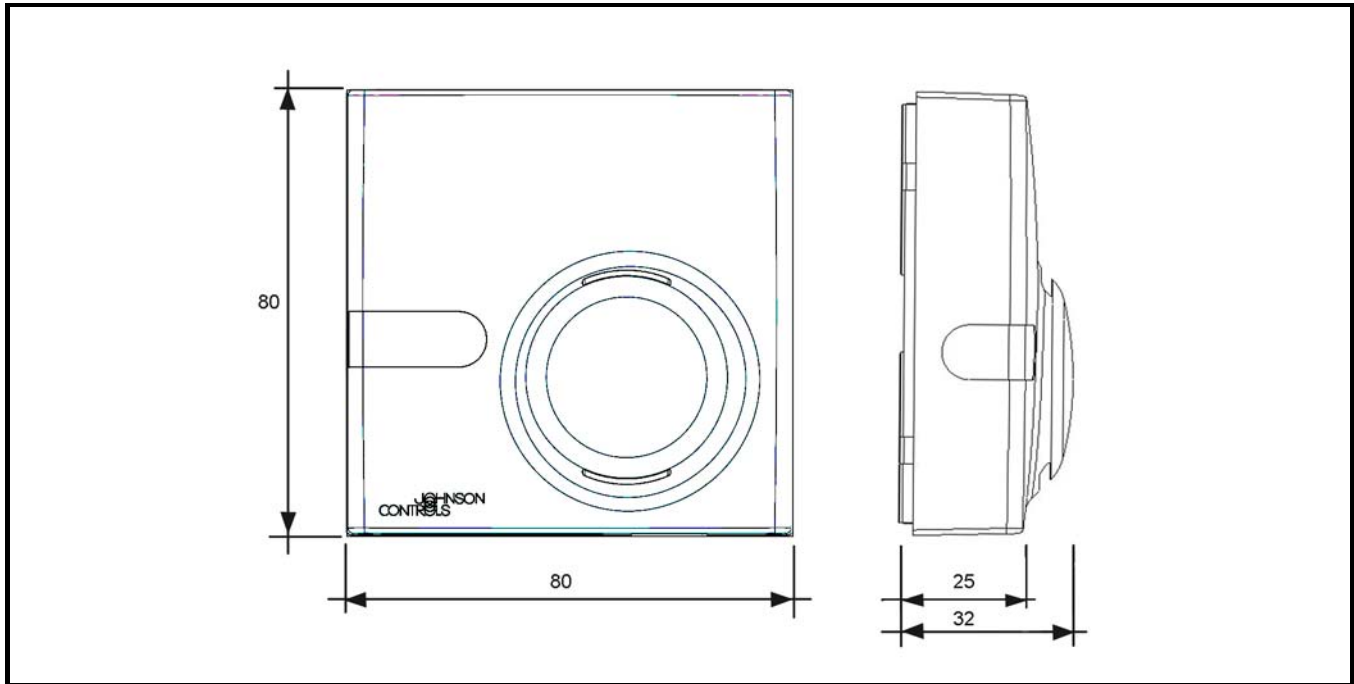

Figure 13: TM-2140-0000

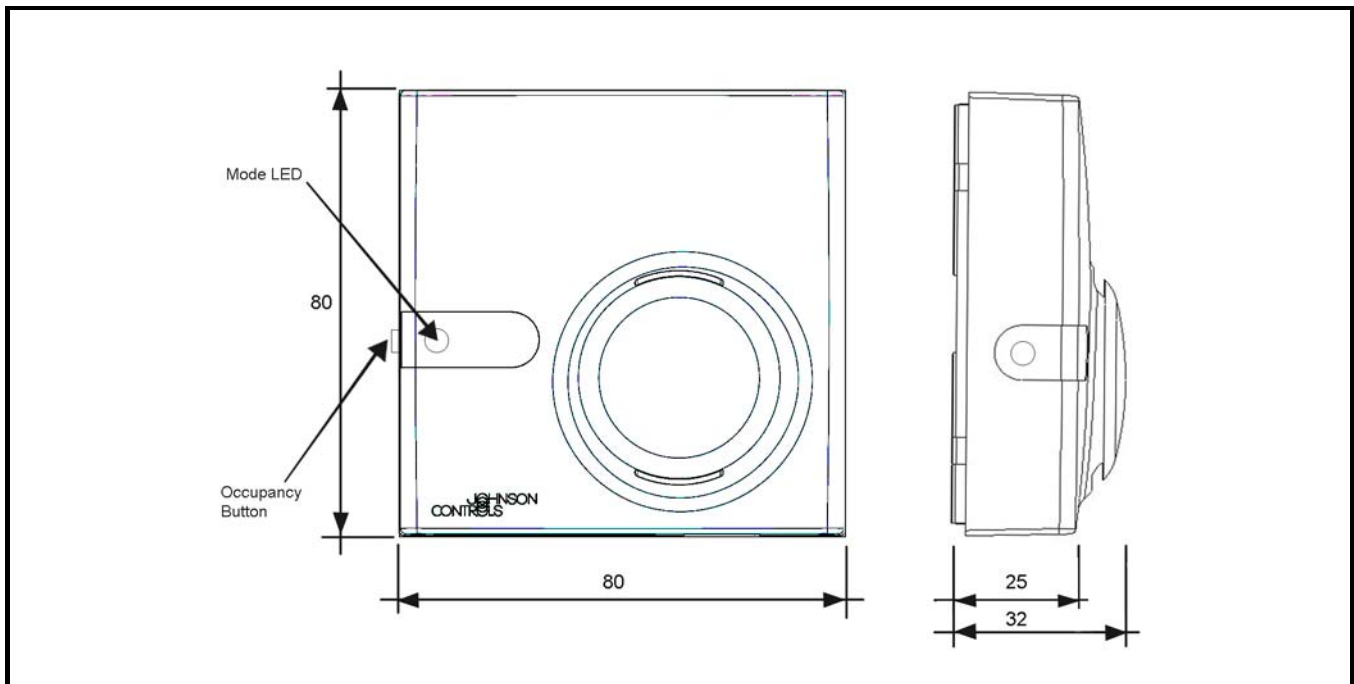

Figure 14: TM-2150-0000

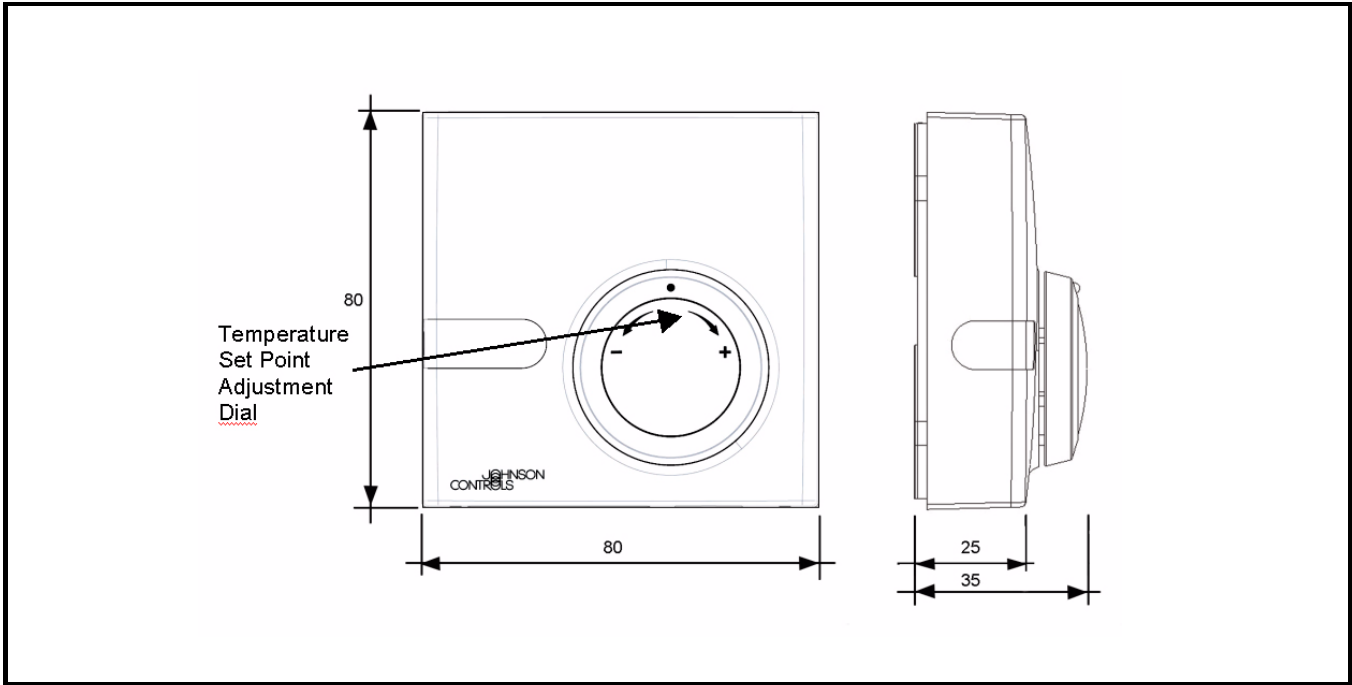

Figure 15: TM-2190-0005

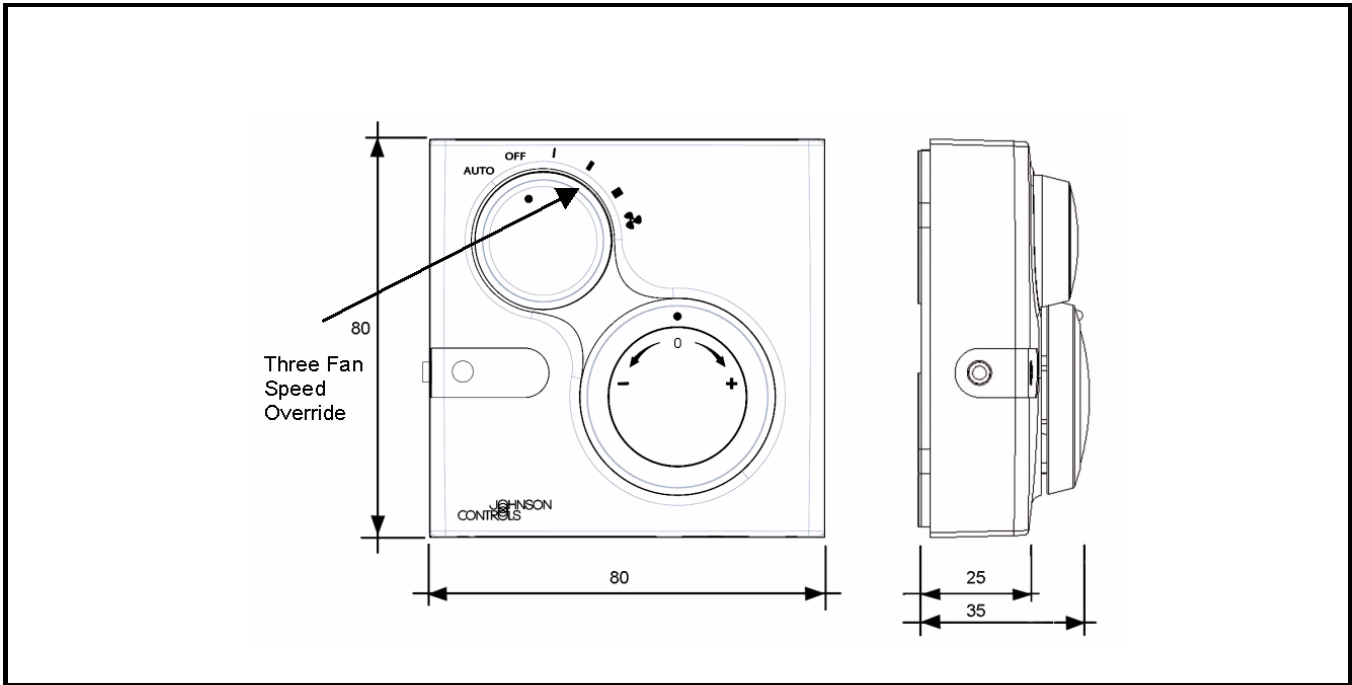

Figure 16: TM-2160-0007

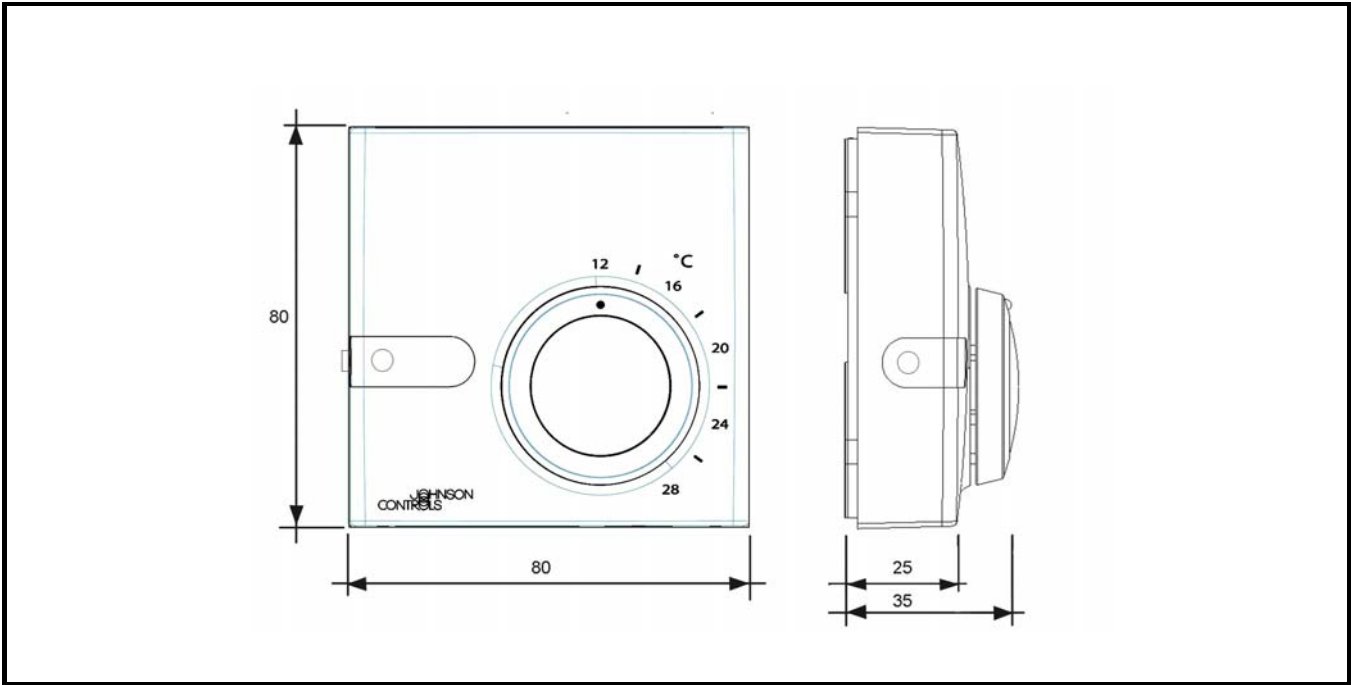

Figure 17: TM-2160-0000

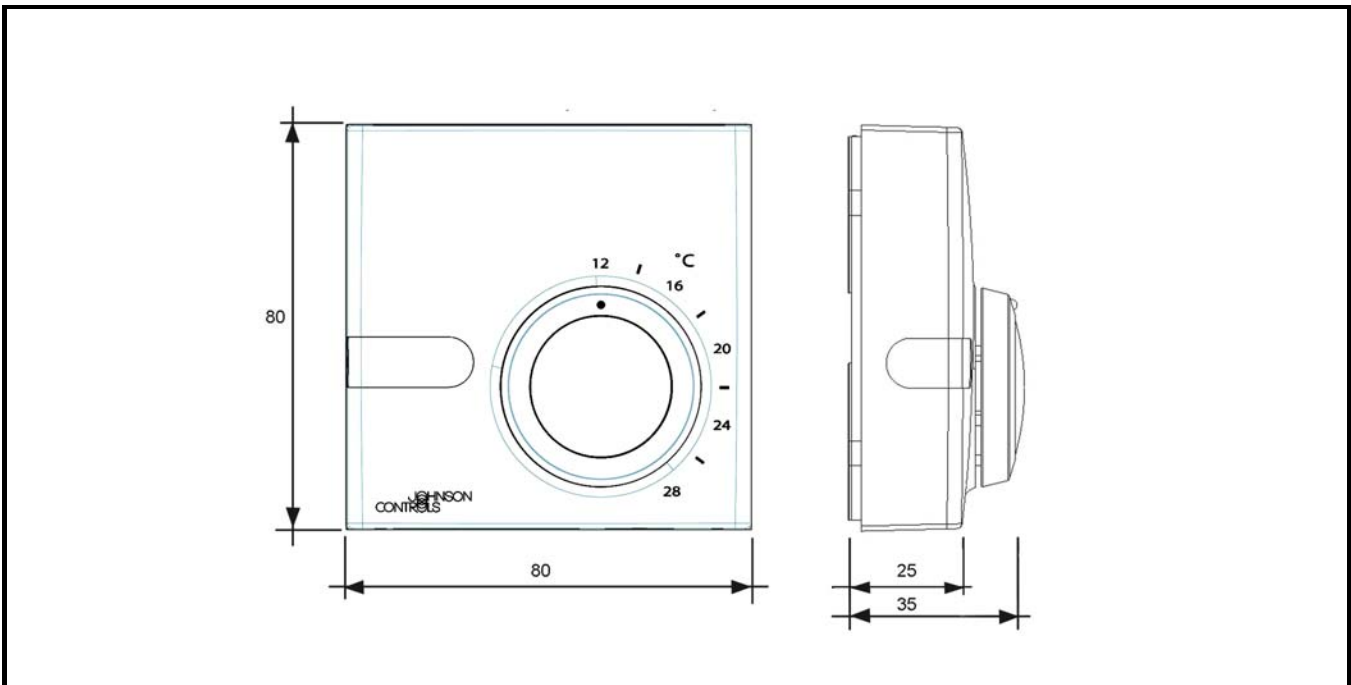

Figure 18: TM-2190-0000

Technical Specifications

Supply Voltage	Power from Controller	
Ambient Operating Conditions	0 to 50°C 10 to 90% RH non condensing	
Ambient Storage Conditions	-20 to 70°C 10 to 90% RH non condensing	
Terminations	Terminal block in base for 1 x 1.5 mm ² (maximum) cable.	
Temperature Sensor	NTC Thermistor 0 to 50°C, 10 kOhm at 25°C	
Remote Set Point	10 kOhm potentiometer marked for 12°C to 28°C or ± (range ±3 K) as configured in controller	
3-Speed Fan Override	10 kOhm potentiometer with mechanically guided positions for Auto, Off, I (low speed), II (medium speed) and III (high speed).	
Occupancy Button	Momentary contact (switches 5V at 1 mA).	
Mode Indicator	Green LED (5V, 4 mA)	
Mounting	Direct surface mount or plastic base for surface mount with wiring conduits (See Ordering Codes.)	
Materials	Enclosure	ABS+PC; self extinguishing HB UL 94
	Base	
	Occupancy Override Button	
	Fan Speed Override Dial	
	Setpoint Dial	
Colors	Enclosure	White RAL9016 (GE86280)
	Base	
	Occupancy Override Button	
	Fan Speed Override Dial	
	Setpoint Dial	Grey RAL7047 (GE GY81118)
Protection Class	Enclosure	IP30 (EN 60529)
Dimensions (H x W xS)	TM-2140-0000	80 mm x 80 mm x 32 mm
	TM-2150-0000	
	TM-2160-000x	80 mm x 80 mm x 35 mm
	TM-2190-000x	
Shipping Weight	0.15 kg	
CE Conformity	EMC Directive 89/336/EEC	EN-61000-6-3
		EN-61000-6-2

The performance specifications are nominal and conform to acceptable industry standard. For application at conditions beyond these specifications, consult the local Johnson Controls office. Johnson Controls, Inc. shall not be liable for damages resulting from misapplication or misuse of its products.



Johnson Controls International, Inc.
Headquarters: Milwaukee, Wisconsin, USA
Branch Offices: Principal Cities World-wide