



techsystem

automatyka klimatyzacja wentylacja

▸ zapoznaj się z naszą ofertą

Series P45

Lube-oil Protection Controls With Built-in Time Delay Switch

/Introduction

The series P45 controls are designed to give protection against low lube-oil pressure on pressure lubricated refrigeration compressors. The controls measure the pressure differential (net oil pressure) between the pressure generated by the oil pump and the refrigerant pressure at the crankcase. A built-in time delay switch allows pressure build-up during start and avoids nuisance shut-down on pressure drops of short duration during the running cycle.



P45 Style 5



P45 Style 13

Feature and Benefits	
<input type="checkbox"/> Several million in use today.	Proven to be a reliable product.
<input type="checkbox"/> Heavy duty pressure elements.	Long-life control. Withstands higher overrun pressure of 29 bar.
<input type="checkbox"/> Key specifications match/exceed other brands.	Easily replaces existing lube-oil controls.
<input type="checkbox"/> Accurate 0.2 bar switch differential standard.	Covers more applications.
<input type="checkbox"/> Adjustable or fixed setpoint.	One model can be used on several applications.
<input type="checkbox"/> Safelight output standard.	More customer flexibility.
<input type="checkbox"/> Trip-free manual reset.	Better compressor protection.
<input type="checkbox"/> High current rated output.	Can be used in more applications.
<input type="checkbox"/> Ambient compensated timing.	Stable delay time.

Description

The P45 series is a differential pressure switch which senses the oil pressure and the suction pressure on compressors using non corrosive refrigerant.

When the compressor is started, the time delay switch is energised. If the net oil pressure does not build up to the "heater-off" point of the control within the required time limit, the time delay switch trips to stop the compressor. If the net oil pressure rises to the "heater-off" point within the required time after the compressor starts, the time delay switch is automatically de-energised and the compressor continues to operate normally. If the net oil pressure should drop below the "heater-on" setting during the running cycle, the time delay switch is energised and, unless the net oil pressure returns to heater "off" point within the time delay period, the compressor will be shut down. The compressor can never run more than the predetermined time on subnormal oil pressure.

Function

- A. During start-up the lube-oil pressure is built up to the control setpoint plus the mechanical differential, before elapse of the delay period ②. Then the time delay heater is de-energised. i.e. normal oil conditions have been established.
- B. During start-up the lube-oil pressure does not build up a pressure to the setpoint plus mechanical switch differential level before the end of the delay period ②. The compressor will stop. Terminal A, when connected to a signal will be activated.
- C. During running period the lube-oil pressure falls to a value lower than the setpoint (cut-out). The timer will be activated.
- D. The lube-oil pressure reaches the setpoint plus mechanical switch differential value before the delay period ② elapses. The heater will be de-energised. The compressor lube-oil conditions are normal again.
- E. The lube-oil pressure falls to a lower value than the setpoint (cut-out). The timer will be activated.

- F. The lube-oil pressure remains at a lower value than the setpoint plus the mechanical differential during the delay period ②. The compressor will stop. Terminal A, when connected to a signal will be activated. Restart can only be performed after about 5 min. by means of pushing the reset button, provided the cause of the fault has been determined.

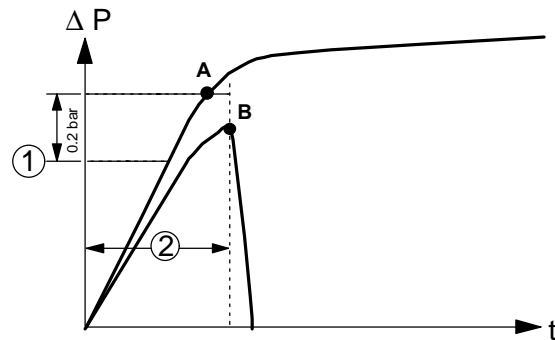

Fig. 1a
During start up

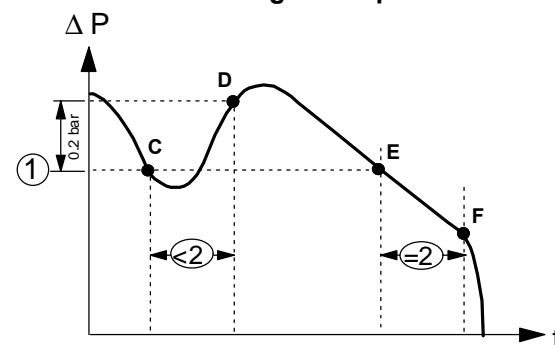

Fig. 1b
During operation

- ① Setpoint in bar (factory set see data label)
- ② Time delay in s. (see data label)

System Check

It is important that the function check be made to insure that the differential pressure control is operating correctly. This check can be made by pressing the lever on the right side of the control for a period corresponding to the delay time.

When the test is correctly executed the compressor stops after the delay time determined by the time delay has elapsed.

Note

These controls are designed for use only as operating controls. Where an operating control failure would result in personal injury or loss of property it is the responsibility of the installer to add devices or systems that protect against, or warn of, control failure.

Time delay switch

The time delay switch is a trip-free, expansion rod device actuated by a resistance heater which is wired as an integral part of the control. Models are available for 50, 90 or 120 seconds.

Optional construction note (For quantities only)

Time delay switches.

- For 12 V and 24 V ac/dc and 120 Vac are available on request.
- 30, 45 or 60 sec. time delay.

Pressure connections.

- Controls with 90 cm capillary with 1/4" braze connection (style 34) may be supplied on quantity orders, when specified.

Various.

- PG nipple
- Field adjustable setpoint
- Bulk pack
- Mounting bracket

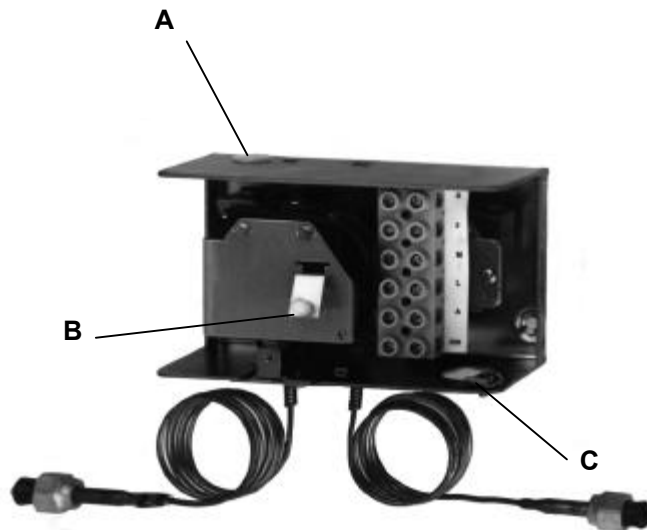

Fig. 2
P45 interior.

- A. Cap for sealed adjustment (factory set)
- B. Reset button
- C. Conduit opening: 22.3 mm hole for PG16 nipple or conduit connector

Adjustment

The P45 is normally factory set and is available with optional field adjustment. However the factory set models can be adjusted by using adjusting wrench WRN12-1. Field adjustable models can be set with a screwdriver. As the P45 has no scale, the setpoint must be checked by using manometers.

Repair and replacement

Repair is not possible. In case of an improperly functioning control, please check with your nearest supplier. When contacting the supplier for a replacement you should state the type/model number of the control. This number can be found on the data plate or cover label.

Type number selection table

Order number	Delay time (s)	Pressure connection	Voltage V ac
P45NCA-9056	50	13	230/115
P45NCA-9104	120	13	230/115
P45NCA-9641	50	13	230/115
P45NBB-9341	50	5	230
P45NBB-9640	50	13	230
P45NBB-9361	90	5	230
P45NBB-9660	90	13	230
P45NBB-9381	120	5	230
P45NBB-9680	120	13	230

Note: If your requirements are not in the type number selection table, then please contact your Johnson Controls representative.

Setting specification

Setting (bar)	Suffix	Setting (bar)	Suffix	Setting (bar)	Suffix
0.5	A	1.0	F	1.5	M
0.6	B	1.1	G	1.6	N
0.7	C	1.2	H	1.7	P
0.8	D	1.3	K	1.8	Q
0.9	E	1.4	L	1.9	R
				2.0	S

When ordering, the corresponding suffix for the required setpoint must be indicated after the model number. For example: P45NBB-9660M is a P45 set at 1.5 bar.

Typical wiring diagrams

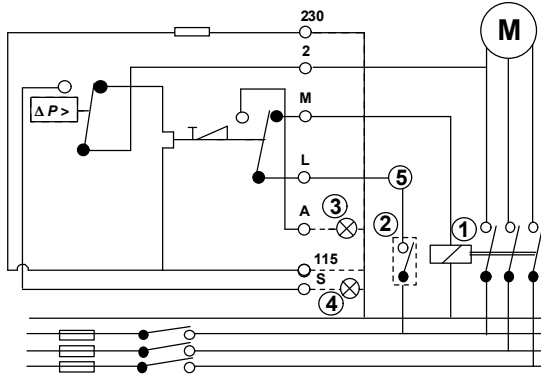

Fig. 3
P45NCA

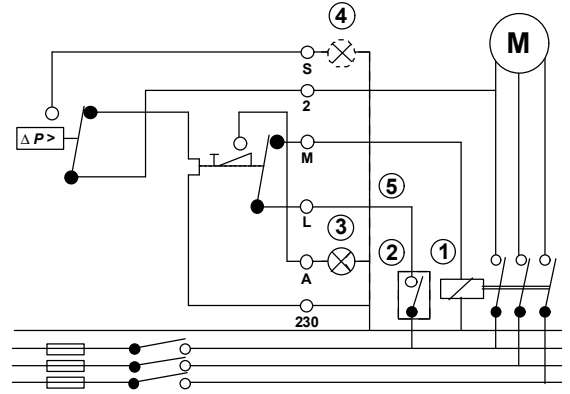

Fig. 4
P45NBB

1. Magnetic starter relay
2. Operating control
3. Alarm light
4. Safe light
5. Additional controls only in this line

Pressure connections

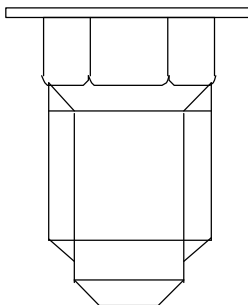

Fig. 5
Style 5
1. 7/16-20 UNF male for
1/4" SAE flare tube

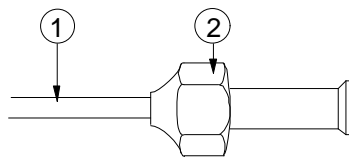

Fig. 6
Style 13
1. 90 cm capillary
2. 7/16-20 UNF nut for 1/4"
SAE flare tube

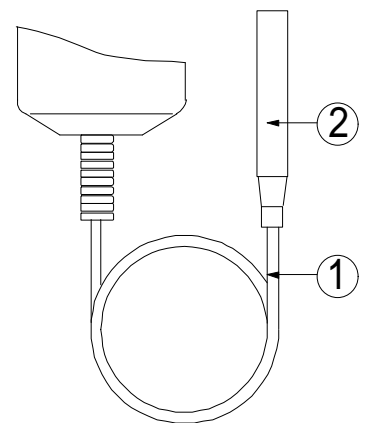
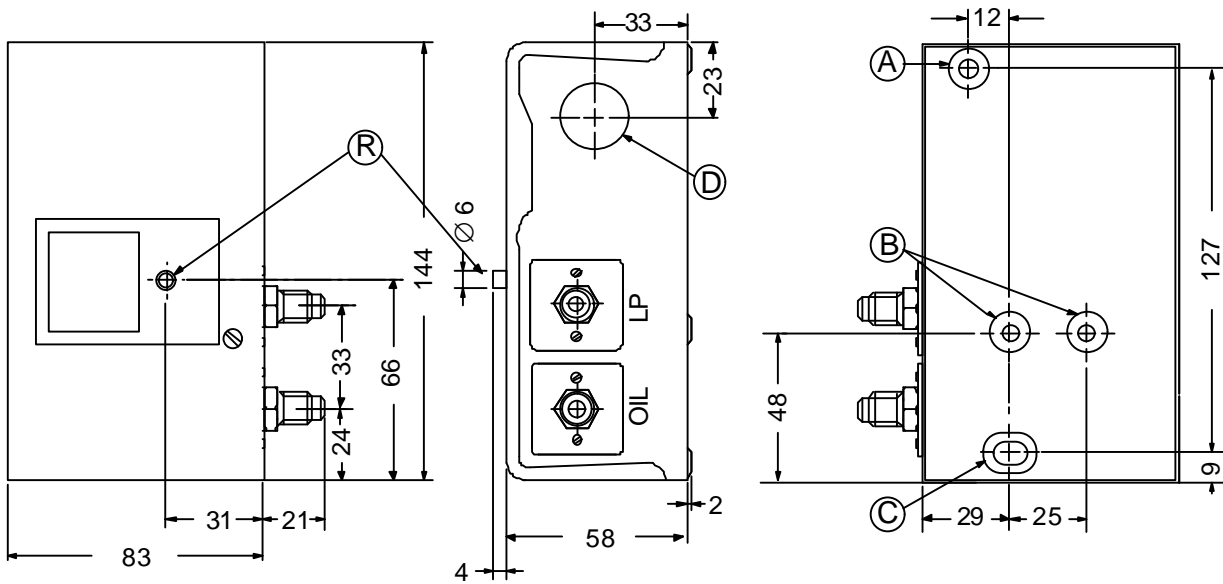
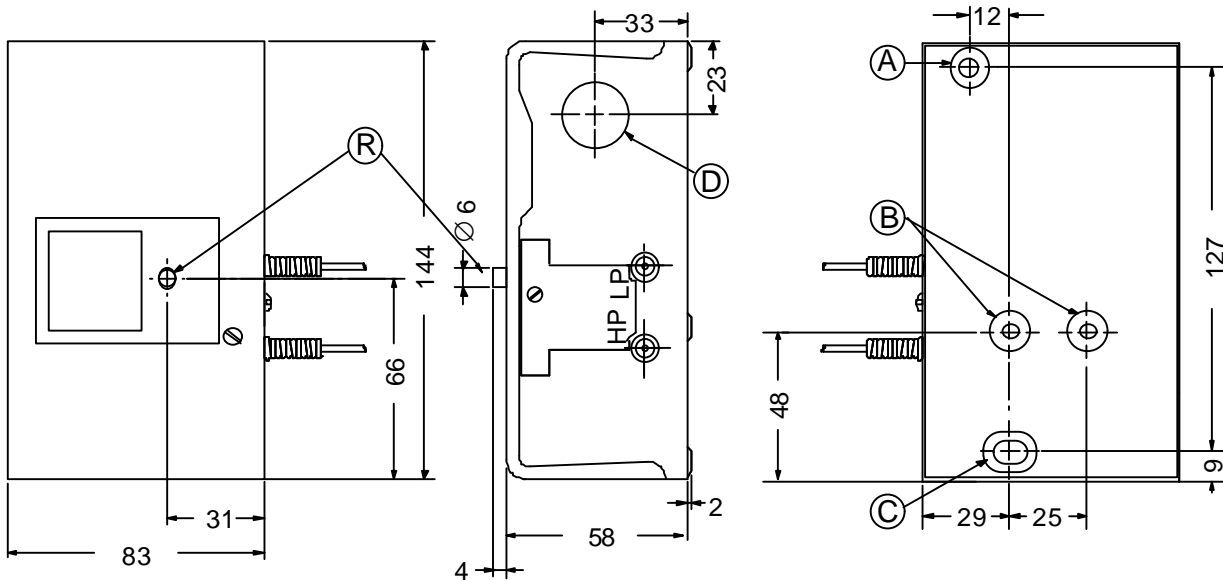

Fig. 7
Style 34 (Optional)
1. 90 cm capillary
2. 1/4" ODM Braze
connection

Dimensions (mm)



**Style 5
Fig. 8**



Style 13

- A. Mounting hole, 5 mm dia.
- B. (2) Mounting holes, threaded 10 - 32 UNF
- C. Mounting slot, 9.5 x 5 mm
- D. Conduit hole, 22.3 mm dia., for PG-16 nipple
- R. Reset button

Fig. 9

Notes

Optional accessories

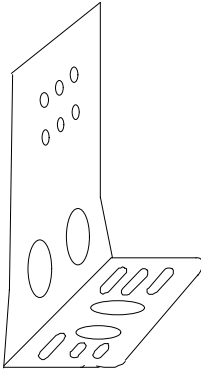

Fig. 10
Mounting bracket
Order number **271-51**

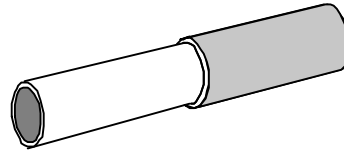

Fig. 11
Adjusting wrench
Order number **WRN12-1**

Specifications

Type number	See type number selection table	
Refrigerant	Non-corrosive, all range	
Alarm contact	Yes	
Safe light contact	Yes	
Operating range	0.5 to 4 bar	
Ambient temperature	-40 to +60 °C	
Maximum allowable overrun pressure	29 bar	
Material	case	1.5 mm cold-rolled steel, zinc plated
	cover	0.8 mm cold-rolled steel, painted
Enclosure	IP 30	
Electrical rating pilot circuit	~15(8)A 230 V	
Shipping weight	ind. pack	1.5 kg
	overpack	16 kg (10 pieces)
Accessories	Mounting bracket	order number 271-51
(order separately)	Adj. wrench	order number WRN12-1
Dimensions	(see Dimension drawing)	

Time delay heater de-energised at 0.2 bar pressure difference above setting.

Note: 1 bar = 100 kPa ≈ 14.5 psi.

The performance specifications are nominal and conform to acceptable industry standards. For applications at conditions beyond these specifications, consult the local Johnson Controls office or representative. Johnson Controls shall not be liable for damages resulting from misapplication or misuse of its products.

**JOHNSON
CONTROLS**

Johnson Controls International, Inc.

Headquarters: Milwaukee, WI, USA
 European Headquarters: Westendhof 8, 45143 Essen, Germany
 European Factories: Lomagna (Italy), Leeuwarden (The Netherlands) and Essen (Germany)
 Branch Offices: Principal European Cities.

This document is subject to change

Printed in Europe