



techsystem

automatyka klimatyzacja wentylacja

▸ zapoznaj się z naszą ofertą

Refrigeration Field Controllers

MR40 Advanced Electronic Control for Compressor and Defrost management (1/4)



MR40 Series

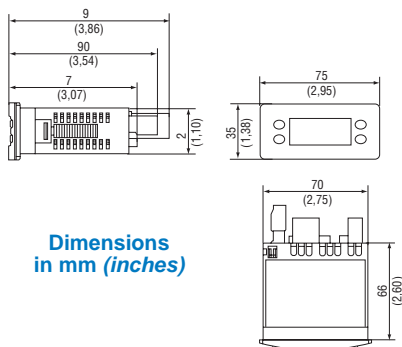

Dimensions
in mm (inches)

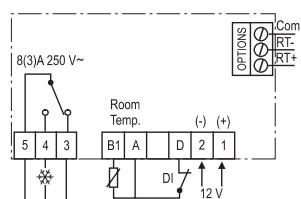

MR42PM12R-1C Wiring

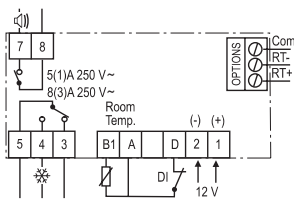

MR42PM12R-A1C Wiring

Description

The MR40 is a digital controller for "static" or "ventilated" refrigeration units working at positive or negative temperatures. It incorporates all the features needed by modern units such as compressor and evaporator fan full management, "off-cycle" or "active" defrost control, additional auxiliary output for alarm signalling or light control.

The MR40 functions can be further expanded through other elements such as the LON or Johnson Controls N2 Open serial communication card. It is also optionally equipped with a Real Time Clock card for energy saving and real time scheduling of events such as defrost cycles.

Features

- Attractive Panel mount enclosure
- Up to 4 relays in the standard 35 x 72 mm enclosure
- Temperature display with "decimal" accuracy
- Decimal Point Visualisation
- Accurate and interchangeable IP 68 sensor
- Wide range of sensors with various enclosures available
- SMD technology
- LON and N2 Open™ serial communication cards (optional)
- Real Time Clock (optional)
- MFood Ready

MR42 Advanced Thermostats with "off cycle" Defrost - Selection Table

Range (°C)	Enclosure	Power Supply	Display	Output Rating 250 VAC				Protection Class	Additional Features	Ordering Codes
				Compressor	Alarm	Defrost	Fan			
-40 to +70	Panel	12 VAC/DC	3 digits	SPDT 8(3)A				Overall IP20 Faceplate IP54	Accuracy: ±0.3 °C Power Consumption: 2.5 VA 50/60 Hz	MR42PM12R-1C
				SPDT 8(3)A	SPDT 8(3)A					MR42PM12R-A1C

Refrigeration Field Controllers

MR40 Advanced Electronic Control for Compressor and Defrost management (2/4)

MR43 Advanced Thermostats with Active Defrost Management - Selection Table

Range (°C)	Enclosure	Power Supply	Display	Output Rating 250 VAC				Protection Class	Additional Features	Ordering Codes
				Compressor	Alarm	Defrost	Fan			
-40 to +70	Panel	12 VAC/DC	3 digits	SPDT 8(3)/A		SPDT 8(3)/A		Overall IP20 Faceplate IP54	Accuracy: ±0.3 °C Power Consumption: 2.5 VA 50/60 Hz	MR43PM12R-2C

MR44 Advanced Thermostats with Defrost and Fan Management - Selection Table

Range (°C)	Enclosure	Power Supply	Display	Output Rating 250 VAC				Protection Class	Additional Features	Ordering Codes
				Compressor	Alarm	Defrost	Fan			
-40 to +70	Panel	12 VAC/DC	3 digits	SPDT 8(3)/A	SPST 8(3)/A	SPDT 8(3)/A	SPDT 8(3)/A	Overall IP20 Faceplate IP54	Accuracy: ± 0.3 °C Power consumption: 2.5 VA 50/60 Hz	MR44PM12R-A2C

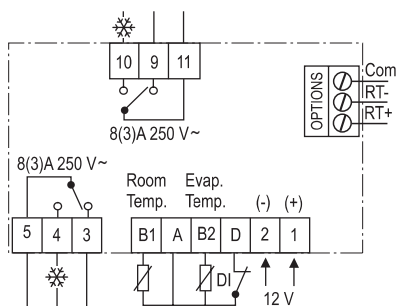

MR43PM12R-2C Wiring

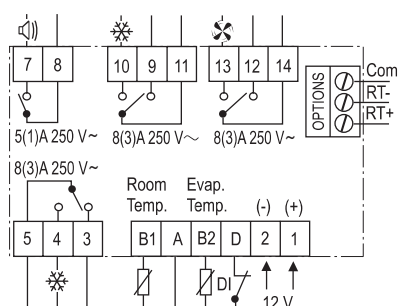

MR44PM12R-A2C Wiring

Refrigeration Field Controllers

MR40 Advanced Electronic Control for Compressor and Defrost management (3/4)

Parameters Descriptions

Display Code	Parameter	Setting Range	Default	MR42	MR43	MR44
Temperature control parameters						
Hy	Hysteresis	1 to 9 K	2	•	•	•
LL	Lower setpoint limit	-40 °C to 70 °C	-40	•	•	•
HL	Higher setpoint limit	-40 °C to 70 °C	70	•	•	•
CC	Anti short cycling	0 to 9 min	2	•	•	•
Co	Deep freezing time	0 to 99 min	60	•	•	•
Alarm parameters						
AH	Higher temperature alarm	0 to 50 °C	10	●	●	●
AL	Low temperature alarm	-50 to 0 °C	-10	●	●	●
Ad	Alarm differential	1 to 9 K	1	●	●	●
At	Alarm time delay	0 to 99 min	30	●	●	●
AC	Alarm delay after power-up and defrost	0 to 99 min	20	●	●	●
Defrost parameters						
dF	Defrost function	OFF(0) = "Off-Cycle" ELE(1) = Electric heater HGA(2) = Hot gas	ELE		●	●
dn	Defrost initiation mode	0 = Internal timer 1 = Real Time Clock	0	●	●	●
dE	Defrost end function	0 = By temperature 1 = By time 2 = First occurrence 3 = Last occurrence	0		●	●
dt	Defrost termination temp	0 to 20 °C	7		●	●
di	Defrost interval time	0 to 99 hours	6	●	●	●
dd	Max. defrost duration	0 to 99 min	40	●	●	●
dC	Dripping time	0 to 99 min	5	●	●	●
dU	First defrost after power on	oFF, 0 to 99 min	oFF	●	●	●
dP	Display during defrost	0 = Last value before defrost 1 = Setpoint	0	●	●	●
dr	Delay displayed temp after defrost	1 to 99 min	20	●	●	●
Digital input parameters						
iF	Digital input function	0 = Not connected 1 = General alarm 2 = Delayed alarm 3 = Door switch 4 = Setpoint bias 5 = Defrost start 6 = oFF mode 7 = AUX output control 8 = Fan only mode	0	●	●	●
id	Digital input time delay	0 to 99 min	5	●	●	●
ib	Setpoint bias	-10 to +10k	3	●	●	●
Fan control parameters						
FF	Fan operating function	0 = Parallel to compressor 1 = Always ON 2 = By temperature <i>Fan always OFF during defrost</i>	0			●
Fd	Fan start-up delay after defrost end and power-up	0 to 99 min.	5			●
Fr	Fan start-up temperature after defrost end and after power-up	-30 to +5 °C	5			●
FS	Fan differential	-30 to +5 °C	-5			●
FH	Fan hysteresis	0 to 20 °C	2			●

Refrigeration Field Controllers

MR40 Advanced Electronic Control for Compressor and Defrost management (4/4)

Parameters Descriptions

Display Code	Parameter	Setting Range	Default	MR42	MR43	MR44
Other parameters						
SF	Thermostat functioning if sensor failure	on(1) = Always ON oFF(0) = Always OFF AUt(2) = Automatic	AUt	●	●	●
So	Sensor offset	-20 to +20 units	0	●	●	●
Un	Temperature units	0 = °C 1 = °F	0	●	●	●
Pd	Virtual temperature weight	0 to 100 %	0	●	●	●
AA	Programmable digital output	0 = Alarm 1 = Auxiliary	0	●		●
Add	Serial address	1 to 255	255	●	●	●
Real Time Clock parameters						
HH	Hour setting	0 to 23	0	●	●	●
nn	Minute setting	0 to 59	0	●	●	●
dAy	Day of the week setting	0 = Sunday 1 = Monday 2 = Tuesday 3 = Wednesday 4 = Thursday 5 = Friday 6 = Saturday	0	●	●	●
dHx x = 1 to 6	Event No. x Hour setting	0 to 23	8	●	●	●
dnx x = 1 to 6	Event No. x Minute setting	0 to 59	0	●	●	●
ddx x = 1 to 6	Event No. x weekday setting	0 = Never 1 = All days 2 = From Monday to Friday 3 = Saturdays & Sundays 4 = From Monday to Saturday 5 = Sundays only	0	●	●	●
biH	Bias Start Hour	0 to 23	20	●	●	●
bin	Bias Start Minute	0 to 59	0	●	●	●
bi	Bias Status	On / Off	oFF	●	●	●
bSH	Bias Stop Hour	0 to 23	0	●	●	●
bSn	Bias Stop Minute	0 to 59	0	●	●	●