



# techsystem

automatyka klimatyzacja wentylacja

▸ zapoznaj się z naszą ofertą

# System 450 Series Modular Controls

## Technical Bulletin

C450xxx-x

Code No. LIT-12011459

Issued April 6, 2009

---

<b>Document Introduction</b> .....	<b>3</b>
<b>Related Documentation</b> .....	<b>3</b>
<b>System 450 Overview</b> .....	<b>4</b>
<b>Control Modules and User Interface</b> .....	<b>5</b>
<b>Expansion Modules, Module Assemblies, and Outputs</b> .....	<b>7</b>
Module Assemblies and Output Numbers .....	7
Relay Outputs .....	8
Analog Outputs .....	8
<b>System 450 Compatible Sensors and Transducers</b> .....	<b>12</b>
<b>System 450 Control Systems</b> .....	<b>13</b>
<b>Detailed Procedures</b> .....	<b>15</b>
<b>Designing and Building System 450 Control Systems</b> .....	<b>15</b>
Selecting Control Sensors .....	15
Assembling System 450 Modules .....	16
<b>Installing System 450</b> .....	<b>16</b>
Locating System 450 Modules .....	16
Mounting .....	17
<b>Wiring System 450</b> .....	<b>18</b>
Wiring System 450 Sensors and Transducers .....	21
<b>Setting Up a System 450 Control System</b> .....	<b>21</b>
Determining Output Numbers and Output Types .....	21
Accessing and Navigating the User Interface .....	22
Setting Up the Control Sensors .....	24
Setting Up a Relay Output .....	25
Setting Up an Analog Output .....	27

***preliminary - this information may change***

Determining the Integration Constant for an Analog Output .....	31
<b>Troubleshooting System 450 Control Systems .....</b>	<b>35</b>
Specified Voltage Ranges for Sensors .....	35
<b>Repair and Replacement .....</b>	<b>36</b>
<b>Technical Specifications .....</b>	<b>39</b>
<b>C450CxN-1 .....</b>	<b>39</b>
<b>C450SxN-1 .....</b>	<b>40</b>
<b>C450YNN-1 .....</b>	<b>40</b>

## Document Introduction

The System 450 Series of modular controls is designed to provide compact, cost-effective, customizable, and accurate digital control for a wide variety of Heating, Ventilation, Air Conditioning, and Refrigeration (HVACR) and commercial/industrial process applications.

This document describes System 450 features and functions, and provides guidelines and instructions for designing, selecting, installing, setting up, and troubleshooting System 450 components and control systems.

This document also provides System 450 *Technical Specifications* on page 39 and references to System 450 *Related Documentation*.

## Related Documentation

Table 1 provides references to System 450 related documentation, including control sensor installation instructions.

**Table 1: Related Documentation**

<b>For More Information On:</b>	<b>Refer to the:</b>	<b>LIT/Part No.</b>
<b>System 450 Series Features, Benefits, Models, and Technical Specifications</b>	<i>System 450 Series Product Bulletin</i>	<i>LIT-12011458</i>
<b>System 450 Series Features, Benefits, Models, and Technical Specifications</b>	<i>System 450 Series Catalog Page</i>	<i>LIT-1900549</i>
<b>Installing, Wiring, and Setting Up System 450 Control Modules with Relay Output</b>	<i>System 450 Series Control Modules with Relay Output Installation Instructions</i>	<i>Part No. 24-7664-2675</i>
<b>Installing and Wiring System 450 Expansion Modules with Relay Output</b>	<i>System 450 Series Expansion Modules with Relay Output Installation Instructions</i>	<i>Part No. 24-7664-2683</i>
<b>Installing and Wiring the System 450 Power Module</b>	<i>System 450 Series Power Module Installation Instructions</i>	<i>Part No. 24-7664-2691</i>
<b>Installing and Wiring the A99 Series Temperature Sensors</b>	<i>A99B Series Temperature Sensors Product/Technical Bulletin</i>	<i>LIT-125186</i> <i>Part No. 24-7664-1636</i>
<b>Installing and Wiring the P499 Series Electronic Pressure Transducers</b>	<i>P499 Series Electronic Pressure Transducers Product/Technical Bulletin</i>	<i>LIT-12011190</i> <i>Part No. 24-7664-2659</i>
<b>Installing and Wiring the HE-67xx Humidity Sensors and Humidity with Temperature Sensors</b>	<i>TrueRH Series HE-67xx Humidity Element with Temperature Sensor Installation Instructions</i>	<i>Part No. 24-9527-7</i>
<b>Installing and Wiring Setra Systems Model 265 Differential Pressure Transducers</b>	<i>Setra Systems Model 265 Differential Pressure Transducer Installation Guide</i>	<i>Search QuickLIT Product Information Web Site for Setra System Model 265.</i>

## **System 450 Overview**

The System 450 Series is a family of compact digital electronic control, expansion, and power modules that are easily assembled and set up to provide reliable On/Off and proportional control of temperature, pressure and humidity conditions in a wide variety of Heating, Ventilation, Air Conditioning, and Refrigeration (HVAC/R) and commercial/industrial process applications.

The System 450 Series is designed to replace System 350 Series and System 27 Series control systems and provides more features and greater flexibility with far fewer model variations. Most System 350 and System 27 modules are designed for single purpose applications (either temperature, pressure, or humidity) and cannot be assembled and configured to control multiple conditions in a controlled system.

The System 450 Series has only nine model variations; each module is designed to be multi-purpose, adaptable, and completely field configurable for temperature, pressure, and humidity applications. The System 450 Series allows you to build a wide range of inexpensive, compact, durable, and versatile custom control systems that allow you to monitor and control multiple control loops in your controlled system. A single System 450 control system can monitor and control temperature, pressure, and humidity simultaneously.

**Note:** System 450 modules are not compatible with System 350 or System 27 modules, but you can build all of the System 350 and System 27 control systems and many more with System 450 modules, usually with fewer modules.

A System 450 control system includes:

- a single System 450 control module, which provides the control system user interface for setting up, monitoring, and controlling your system and the sensor wiring interface for connecting the control sensors
- one to three control sensors, which connect directly to the control module and provide (temperature, pressure, and humidity) input signals for monitoring the control loops in your controlled system.
- one to ten outputs (provided by the control module and expansion modules). Each output provides either On/Off control or a proportional analog signal (0-10 VDC or 4-20 mA) to the equipment in your controlled system.

A System 450 control system can also include a System 450 power module.

See Table 8 on page 36 for a complete list of System 450 modules.

## Control Modules and User Interface

Each System 450 control system requires a single control module. System 450 control modules have a Liquid Crystal Display (LCD) that allows you to monitor the controlled system, along with a four-button touch pad for navigating the control system status and setup screens, and setting the system parameters.

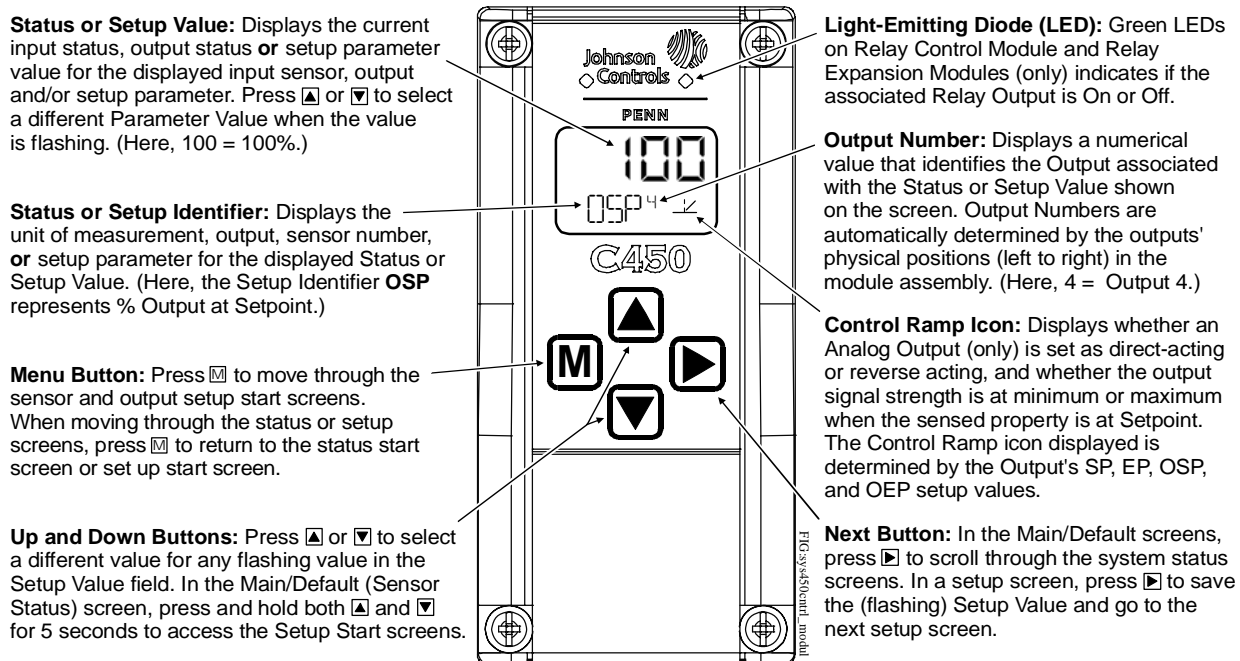

**Figure 1: System 450 Control Module with Relay Outputs Showing LCD and Four-Button Touch Pad User Interface**

System 450 control modules are available with one or two relay outputs or with one or two analog outputs. You set up **all** of the relay and analog outputs in your control system in any control module UI.

A control module can also be configured as a simple stand-alone control system when your application requires only one or two relay outputs or one or two analog outputs.

During normal operation, the LCD displays the Main (default) System 450 screen, which automatically scrolls through and displays the status of each sensor in your control system. You can easily view output status and access the System 450 setup interface from the Main screens. See *Accessing and Navigating the User Interface* on page 22.

The System 450 Output Status screens display the status of each output in the control system. A relay output status is displayed as ON or OFF. An analog output status is displayed as a percentage of the total output signal strength (0-100%).

The setup screens in the System 450 UI enable you to setup the control sensors and all of the outputs in the control system. See Figure 2 and *Setting Up a System 450 Control System* on page 21.

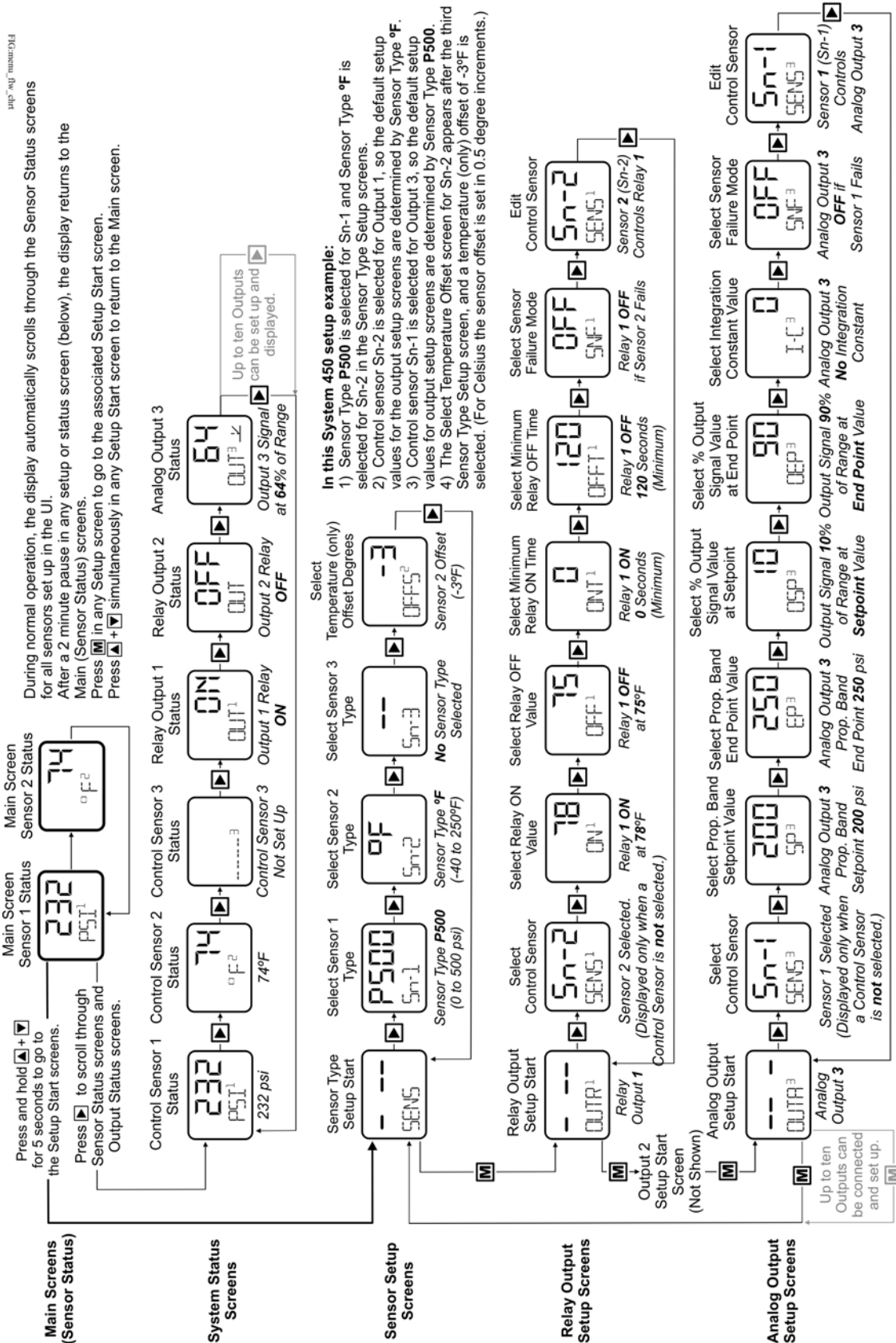

**Figure 2: Example of the System 450 Status and Setup Screens Showing How to Navigate through the Start, Status, and Setup Screens**

## Expansion Modules, Module Assemblies, and Outputs

System 450 expansion modules provide additional outputs to expand control systems and meet specific application requirements. A System 450 control system can provide up to 10 outputs, which can be any combination of relay and analog outputs. Expansion modules are available with one or two relay outputs, or with two analog outputs. See Table 8 on page 36 for System 450 module information.

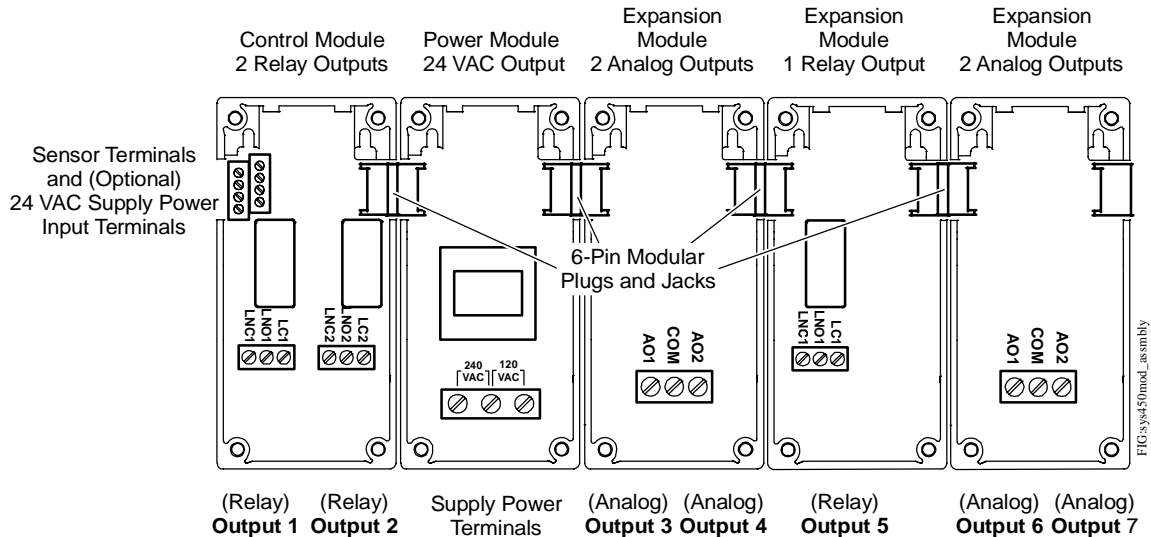

**Figure 3: System 450 Module Assembly Example Showing Control, Power and Expansion Module Positions, Output Positions, and Output Numbers**

### Module Assemblies and Output Numbers

You can easily plug System 450 modules together at the 6-pin plugs and jacks located on the sides of the modules' housings and mount these module assemblies on standard 35 mm DIN rail (recommended) or directly to a hard, even surface. See [Mounting](#) on page 17 for more information.

The control module is always mounted on the left side of the module assembly. If a System 450 power module is used, the power module is always plugged into the right side of the control module. If expansion modules are used, they can be plugged into the assembly in any order on the right side of the power module. See [Assembling System 450 Modules](#) on page 16 for more information.

Each time a System 450 module assembly is powered On, the control module polls all of the modules to identify output type (relay or analog) and then assigns an output number (1 to 9 and 0 = 10) to each output, starting with the control module output on the left. Output numbers are displayed on the control module LCD to identify the output you are viewing as you navigate the system status and set up screens in the UI (Figure 1).

Figure 3 shows a System 450 module assembly example, the module positions, the output types, and the automatically assigned output numbers used in the system setup in the control module UI.

## Relay Outputs

Relay outputs provide low and line-voltage On/Off control for devices and equipment in your controlled systems. You can set up multiple relay outputs to create a variety of equipment staging configurations.

Each relay output is a Single-Pole, Double-Throw (SPDT) set of dry contacts (Figure 7). The relay terminals do **not** supply power to your controlled system. See *Technical Specifications* on page 39 for the relay electrical ratings. See *Wiring System 450* on page 18 for information on wiring output relays.

A green Light-Emitting Diode (LED) on the relay control and relay expansion module housings (Figure 1) indicates the relay output status.

When a relay output is **On**:

- the corresponding green LED on the module housing is lit
- the LNO (Line Normally Open) relay contact is closed
- the LNC (Line Normally Closed) relay contact is open
- the corresponding Output Status screen in the UI displays ON

When a relay output is **Off**:

- the corresponding green LED on the module housing is not lit
- the LNO relay contact is open
- the LNC relay contact is closed
- the corresponding Output Status screen in the UI displays OFF

See *Setting Up a Relay Output* on page 25 for procedures on setting up relay outputs in the System 450 UI.

Control and expansion modules are available with one or two relay outputs. See Table 8 on page 36 for System 450 model information.

## Analog Outputs

Analog outputs provide proportional analog signals for devices and equipment in your controlled systems. Each analog output can generate either a 4-20 mA or 0-10 VDC signal. The output signal type is self-selecting; after you connect the analog output to the controlled equipment, the output detects the analog input on the controlled equipment and generates the appropriate analog signal.

You can set up an analog output to generate a direct-acting or reverse-acting proportional output signal. You can also set up the output signal strength to increase or decrease in either the direct-acting or reverse-acting mode. See *Direct and Reverse Control Actions* on page 9 for more information.

System 450 also provides six integration constants that enable you to set up a proportional plus integral control signal, which can provide more precise setpoint control. See *Proportional Plus Integral Control and Integration Constants* on page 10 for information on determining the integration constant for an analog output.

See *Setting Up an Analog Output* on page 27 for procedures on setting up analog outputs in the System 450 UI.

Control module and expansion module models are available with one or two analog outputs. See Table 8 on page 36 for System 450 model information.

### ***Direct and Reverse Control Actions***

An analog output can be set up to provide one of four different control actions, which allow you to match the output signal to the requirements of your control system and the controlled equipment. The proportional output signal can provide direct-acting or reverse acting control. In addition, the output signal can be set up to generate either the minimum or the maximum output signal strength at Setpoint. See Table 2 for more information.





A control ramp icon is displayed on the status screens for all analog outputs in your control system (Figure 1). The displayed control ramp icon represents the control action of the analog output signal.

An analog output's control action and the corresponding control ramp are automatically determined by the values that you select in four analog output setup screens:

- **Setpoint** value (SP) is the target (condition) value that the controlled system drives towards and, along with End Point, defines the system control loop's proportional band.
- **End Point** value (EP) is the (condition) value that the controlled system drives away from (towards Setpoint) and, along with Setpoint, defines the system control loop's proportional band.
- **Output at Setpoint** value (OSP) is the value (in percent of the total output signal range 0-100%) that drives the controlled equipment to the lowest target output capacity or Off.
- **Output at Endpoint** value (OEP) is the value (in percent of the total output signal range 0-100%) that drives the controlled equipment to a highest target output capacity or maximum output capacity.

Table 2 shows the four available control ramp icons and describes their corresponding control actions and the setup value relationships required to configure the four control actions.

**Table 2: System 450 Control Ramps, Analog Output Control Actions, and System Setup Value Relationships**

<b>Control Ramp Displayed</b>	<b>Control Action and Output Signal Strength at Setpoint</b>	<b>Set the Analog Output Value Relationships for the Desired Control Action and Corresponding Control Ramp</b>
	<b>Direct-Acting</b>  Minimum output signal strength at Setpoint	<b>SP &lt; EP</b> (Set Setpoint less than End Point.)  <b>OSP &lt; OEP</b> (Set Output at Setpoint less than Output at End Point.)
	<b>Reverse-Acting</b>  Minimum output signal strength at Setpoint	<b>SP &gt; EP</b> (Set Setpoint greater than End Point.)  <b>OSP &lt; OEP</b> (Set Output at Setpoint less than Output at End Point.)
	<b>Direct-Acting<sup>1</sup></b>  Maximum output signal strength at Setpoint	<b>SP &gt; EP</b> (Set Setpoint greater than End Point.)  <b>OSP &gt; OEP</b> (Set Output at Setpoint greater than Output at End Point.)
	<b>Reverse-Acting<sup>1</sup></b>  Maximum output signal strength at Setpoint	<b>SP &lt; EP</b> (Set Setpoint less than End Point.)  <b>OSP &gt; OEP</b> (Set Output at Setpoint greater than Output at End Point.)

1. These control actions are typically used to control equipment or devices that generate their maximum output capacity in response to the minimum analog output signal strength.

### ***Proportional Plus Integral Control and Integration Constants***

In addition to standard proportional control, System 450 provides **Proportional plus Integral (PI)** control capability. The addition of integral control enables a properly set up analog output to drive a controlled condition closer to the Setpoint target. (Figure 4).

Standard **proportional-only** controls continuously adjust the output in proportion to the difference (offset error) between Setpoint value and the sensor value. As the load on the system increases, the offset error increases. A proportional-only control responds to the increased offset error by changing the output signal, which drives the controlled equipment to compensate for the load change (Figure 4). Proportional-only control loops are relatively easy to setup and adjust.

Typically, under constant system load, proportional-only control loops do not drive a system to the selected Setpoint. Instead, the controlled system is maintained at a **control point** within the proportional band (throttling range) between the setpoint and end point. The larger the load on the system, the further the control point drifts from the setpoint. Still, for many applications, proportional-only control is the best choice for analog output control.

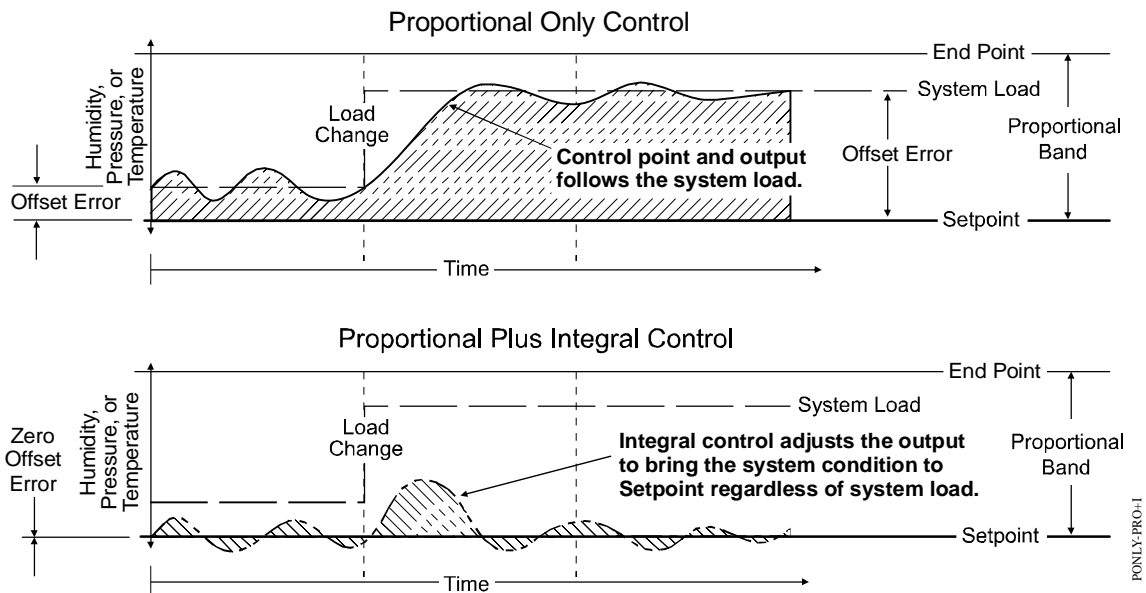

**Figure 4: Proportional Only Control vs. Proportional Plus Integral Control**

**Proportional plus integral (PI) control** incorporates a time-integral control action with proportional control action and if properly set up, a PI control loop can effectively eliminate offset error and enable a controlled system to drive to the target setpoint even under large constant loads (Figure 4). On a properly sized system with predictable loads, PI control can maintain the controlled system very close to the Setpoint value.

A system's output capacity, the size of the load on the system, and the integration constant selected determine the speed (recovery rate) at which the PI control drives the system to Setpoint.

The integration constant establishes the rate at which the control readjusts to the analog output signal. The faster the integration constant, the faster the control readjusts the output signal and the faster the recovery rate of a properly sized and setup loop.

**Note:** PI control is not suitable for all controlled systems. Improperly applied PI control loops are unstable and can overshoot setpoint, resulting in control loop oscillation. Also, with PI control, the proportional band (throttling range) and the integration constant are interdependent and must be set up properly in relation to each other. The system equipment must also be properly sized to handle the maximum load. Close observation (over several cycles and under different load condition) is required to properly set up a PI control loop. On a properly sized system, a PI control loop can drive the system condition much closer to Setpoint than proportional-only control.

In addition to a proportional-only setting, System 450 provides six time-integral settings in the **Integration Constant Setup** screen for matching the analog signal's response rate to the controlled system's recovery rate. The seven integration constant settings are shown in Table 5 on page 34.

See *Determining the Integration Constant for an Analog Output* on page 31 for more information and the procedures for determining an integration constant and testing a PI control loop in your controlled system.

### **System 450 Compatible Sensors and Transducers**

System 450 control modules are designed to operate with a variety of compatible temperature, pressure, and humidity sensors and transducers. Table 3 shows the available sensors and the corresponding Sensor Types, parameter values, and value ranges.

**Table 3: System 450 Sensor Types, Setup Values, and Product Codes**

<b>Sensor Type</b>	<b>Units of Measurement (Condition/Units)</b>	<b>Range of Values</b>	<b>Displayed Resolution Value</b>	<b>Minimum Differential</b>	<b>Displayed Sensor Range</b>	<b>Product Code Numbers<sup>1</sup></b>
°F	°F (Temperature/degrees)	-40 to 250	1	1	-46 to 255	A99B-xxx
°C	°C (Temperature/degrees)	-40 to 121	0.5	0.5	-43 to 124	A99B-xxx
rH	% (Humidity/%RH)	10 to 95	1	2	1 to 100	HE67Sx-x
P 05	INWC (Pressure/in.W.C.)	0.025 to 0.50	0.005	0.025	0 to 0.5	DPT-2650-0R5D-AB
P 8	bAR (Pressure/bar)	-1 to 8	0.05	0.2	-1 to 8	P499RCP-401C
P 10	INWC (Pressure/in.W.C.)	0.5 to 10	0.05	0.2	0 to 10	DPT-2650-010D-AB
P 15	bAR (Pressure/bar)	-1 to 15	0.1	0.2	-1 to 15	P499RCP-402C
P 30	bAR (Pressure/bar)	0 to 30	0.1	0.4	0 to 30	P499RCP-404C
P 50	bAR (Pressure/bar)	0 to 50	0.2	0.4	0 to 50	P499RCP-405C
P100	PSI (Pressure/psi)	0 to 100	0.5	2	0 to 100	P499Rxx-101x
P500	PSI (Pressure/psi)	90 to 500	1	5	0 to 500	P499Rxx-105x
P750	PSI (Pressure/psi)	150 to 750	2	6	0 to 750	P499Rxx-107x

1. See Table 9, Table 10, Table 11, and Table 12 in *Repair and Replacement* on page 36 for a complete list of valid product code numbers and ordering information for System 450 compatible sensors and transducers.

The Sensor Type (that an output references) automatically determines the controlled condition, unit of measurement, minimum differential, setup value ranges and the default setup values for the output.

**Note:** For a System 450 control system to operate properly, the correct sensor or transducer model must be wired to the correct sensor input terminals on the control module and the the correct Sensor Type must be selected in the associated **Select Sensor Type** screen in the System 450 UI.

See Table 9, Table 10, Table 11, and Table 12 in *Repair and Replacement* on page 36 for complete product code numbers and ordering information for System 450 compatible sensors and transducers.

See *Wiring System 450* on page 18 for information on System 450 input sensor wiring terminals on control modules. Refer to the sensor literature referenced in *Related Documentation* on page 3 for information on installing, wiring, operating, troubleshooting, and replacing System 450 compatible sensors.

See *Setting Up the Control Sensors* on page 24 for information on setting up the Sensor Types in the System 450 control module UI.

### System 450 Control Systems

System 450 can provide a wide range of cost-effective, custom control systems. Figure 5 and Figure 6 show examples of System 450 control systems for some representative system applications.

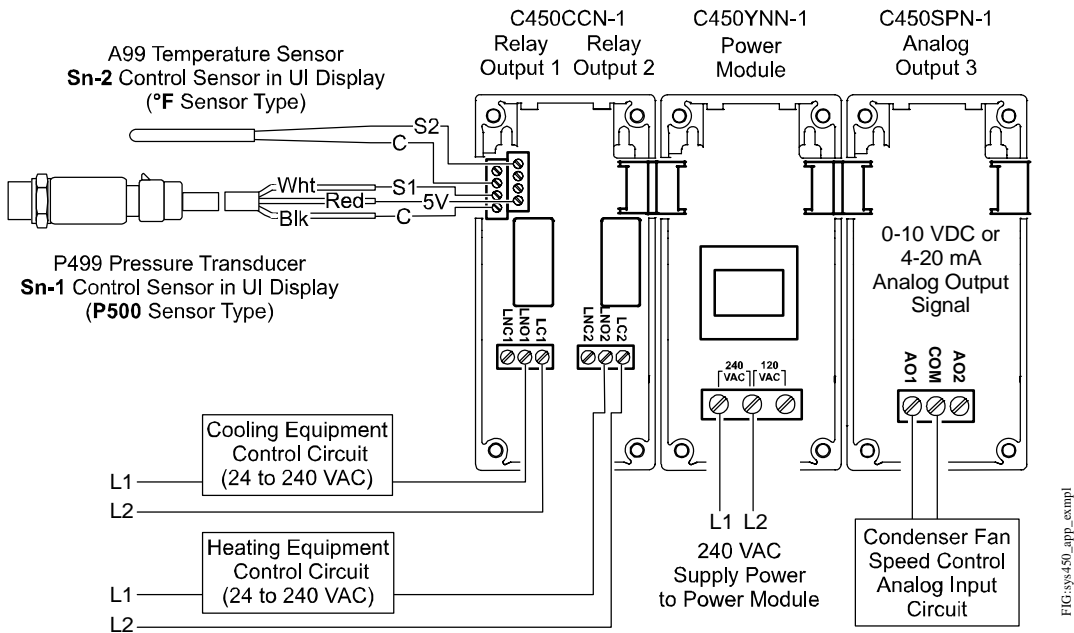

**Figure 5: System 450 Control System for a Room Heating and Cooling Application with Condenser Fan Speed Control**

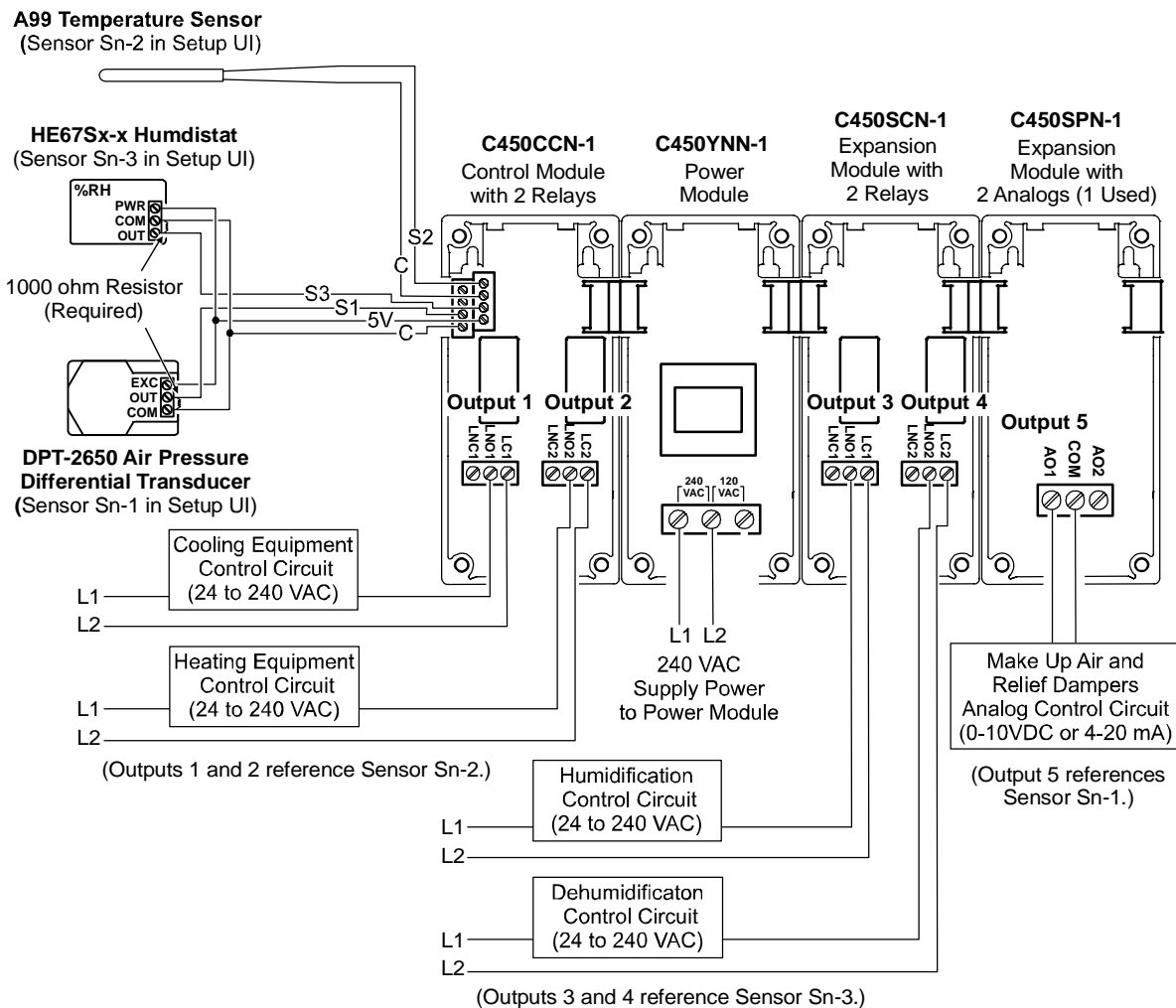

**Figure 6: A System 450 Control System Example for a Clean Room Application That Controls Temperature, Pressure, and Humidity Simultaneously**

## **Detailed Procedures**

### ***Designing and Building System 450 Control Systems***

The variety and flexibility of System 450 modules and sensors allow you to build an almost limitless variety of custom control systems. In fact, for many control systems, different System 450 components can be configured to achieve the same results.

Observe the following guidelines when designing a control system and selecting components:

- Determine the conditions and condition ranges that must be monitored in your application. Up to three sensors can be connected and up to three conditions (temperature, pressure, and humidity) can be monitored simultaneously. See Table 3 on page 12 and *Selecting Control Sensors* for more information.
- Determine the number and type (relay or analog) of outputs required to control the equipment in your application. Up to ten outputs can be configured in and controlled by a single System 450 control system.
- Determine the types of control and expansion modules needed to provide the required outputs for your application and the minimum number of modules required to provide those outputs.

**Note:** Many System 450 control systems can be configured using a different set of module models to build the assembly, but typically there is one configuration that is more cost effective to build than other potential module assembly configurations.

### **Selecting Control Sensors**

In a System 450 control system, each output references a control sensor that is wired to the control module and set up in the control module UI. Observe the following guidelines when selecting, installing, and setting up sensors for your control system:

- Select only System 450 compatible sensors listed in Table 3 on page 12.
- Select only the sensors that match the desired units of measurement and are designed to operate in the temperature, pressure, or humidity ranges that the control system is intended to monitor and control. (See Table 3 on page 12.)
- Ensure that the correct sensor is wired properly to the correct input terminals on the control module. (See *Wiring System 450* on page 18.)
- Ensure that the wire length between the sensors and control module is as short as possible/practical, and ensure that the wiring is properly sized. (Refer to the sensor installation instructions referenced in *Related Documentation* on page 3 for more information on wiring sensors.)
- Ensure that the correct Sensor Type is selected in the System 450 UI for each sensor wired to the control module. (See *Setting Up the Control Sensors* on page 24.)

- Ensure that each output references the correct sensor in the System 450 UI.  
(See *Setting Up a System 450 Control System* on page 21.)

### **Assembling System 450 Modules**

After selecting the System 450 components for your control system, you must assemble the modules. Figure 3 on page 7 shows an example of a System 450 module assembly. Observe the following guidelines when assembling System 450 modules:

- Always locate the control module on the left side of the module assembly.
- Always plug the System 450 power module (when used) into the right side of the control module.
- Plug the expansion modules together, in any order, on the right side of the System 450 power module (or on the right side of the control module when an external 24 VAC power supply is used instead of a System 450 power module). See *Wiring System 450* on page 18 for information on wiring an optional external 24 VAC supply power to System 450 control systems that do not have a power module.

### **Installing System 450**

#### **Locating System 450 Modules**

Observe these guidelines when locating and mounting System 450 modules:

- Ensure that the mounting surface can support the module assembly, DIN rail, mounting hardware, and any (user-supplied) panel or enclosure.
- Mount the modules in a horizontal, upright orientation wherever possible. DIN rail mount is recommended.
- Mount modules directly on only flat and even surfaces.
- Mount the modules in locations free of corrosive vapors and observe the ambient operating conditions in the *Technical Specifications* on page 39.
- Allow sufficient space for making connections, running wires, and viewing LCD for control status and setup.
- Do not mount the modules on surfaces that are prone to vibration or in locations where strong radio frequency or electromagnetic emissions may cause interference.
- Do not install the modules in airtight enclosures.
- Do not install heat generating devices in an enclosure with the modules that may cause the ambient temperature to exceed 66°C (150°F).

## **Mounting**

Mount System 450 modules on 35 mm DIN rail (recommended) or directly to a flat/even surface.

To mount the modules on DIN rail:

1. Provide a section of 35 mm DIN rail that is longer than the module assembly width, and mount the DIN rail in a suitable location using appropriate mounting hardware/fasteners.
2. Clip the control module on the rail, position the module's upper DIN rail clips on the top rail, and gently snap the lower clips on to the bottom of the rail.

**IMPORTANT:** When mounting a module assembly on a DIN rail, clip the modules on to the DIN rail individually before gently sliding and plugging the mounted modules together on the DIN rail. Clipping a complete module assembly that is already plugged together on to the DIN rail can damage the 6-pin modular plugs and void any warranties.

3. Clip the remaining modules to the right of the control module on to the DIN rail and gently slide and plug the modules together. (If a System 450 power module is used, mount the power module to the right of the control module so that the power module plugs directly into the control module.)

To direct mount modules to wall surfaces:

1. Plug the modules together, remove the module covers, place the assembly horizontally against a flat even surface in a suitable location and mark the mounting slot locations on the surface.

**IMPORTANT:** Mount the module assembly only on a flat even surface. Mounting the module assembly on an uneven surface can damage the module housings or the 6-pin modular connectors.

2. Install appropriate screw fasteners, leaving screw heads approximately one to two turns away from flush to the surface.
3. Place the assembly over screw heads and on the mounting slots, and carefully tighten mount screws.

Refer to the sensor installation instructions referenced in *Related Documentation* on page 3 for information on locating and mounting System 450 compatible control sensors.

## **Wiring System 450**

When wiring your System 450 control system, observe the following guidelines and see Figure 7, Figure 8, and Table 4.

Refer to the Technical Specifications table in the module installation instructions referenced in *Related Documentation* on page 3 for module electrical ratings.



**WARNING: Risk of Electric Shock.**

Disconnect each of multiple power supplies before making electrical connections. More than one disconnect may be required to completely de-energize equipment. Contact with components carrying hazardous voltage can cause electric shock and may result in severe personal injury or death.

**IMPORTANT:** Use copper conductors only. Make all wiring in accordance with local, national, and regional regulations.

**IMPORTANT:** Do not exceed the System 450 module electrical ratings. Exceeding module electrical ratings can result in permanent damage to the modules and void any warranty.

**IMPORTANT:** Do not connect supply power to the System 450 modules before checking all wiring connections. Short circuits or improperly connected wires can result in damage to the modules and void any warranty.

Figure 7 and Figure 8 show the wiring terminal details for System 450 control modules and expansion modules.

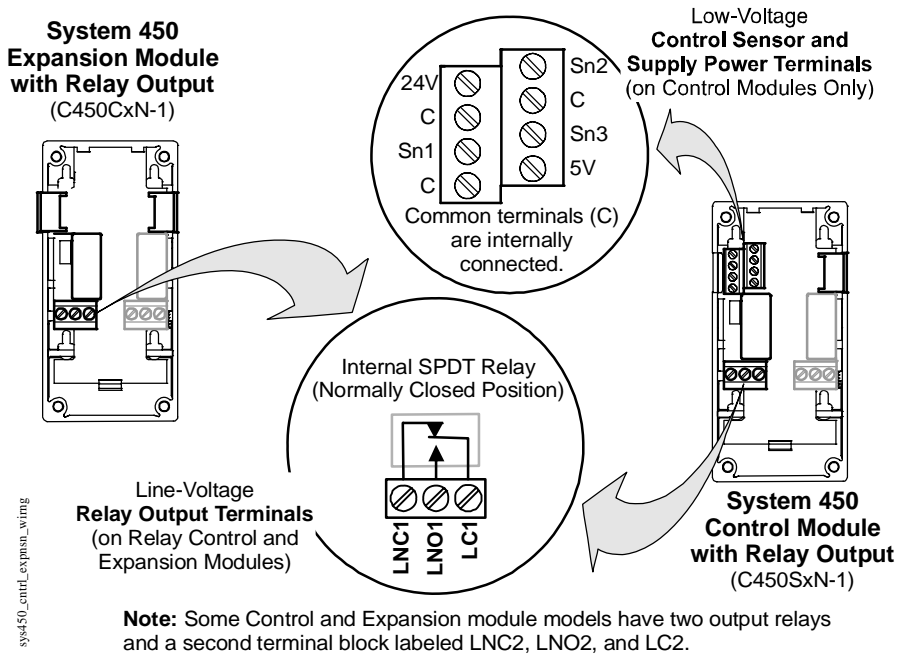

**Figure 7: Wiring Terminal Details for System 450 Control and Expansion Modules with Relay Output**

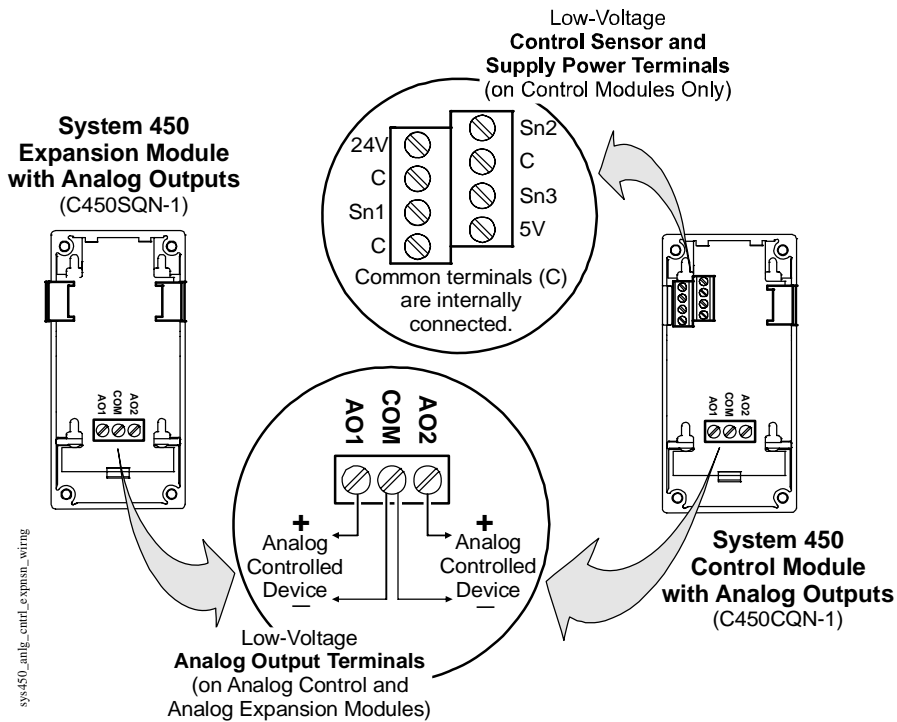

**Figure 8: Wiring Terminal Details for System 450 Control and Expansion Modules with Analog Outputs**

***preliminary - this information may change***

Table 4 provides wiring terminal information and required wire size for System 450 control, expansion, and power modules.

**Table 4: System 450 Wiring Terminal and Wire Size Information**

Terminal Block Type (on Module Type)	Terminal Label	Terminal Function	Required Wire Sizes
Input Sensor and Low-Voltage Input Power Terminal Block (on all Control Modules)	24V	Accepts 24 VAC supply power for module assembly, when a Y450 power module is <b>not</b> used.	28 AWG to 16 AWG 0.3 mm <sup>2</sup> to 1.0 mm <sup>2</sup>
	5V	Supplies 5 VDC power to active control sensors.	
	S1, S2, S3	Accepts passive or active (0-5 VDC) input signals from control sensors	
	C (3 Terminals)	Provides Common connections for external 24 VAC power and passive or active sensors connected to the 5V, S1, S2, and S3 terminals. <b>Note:</b> The three low-voltage <b>C</b> terminals are connected internally and can be connected to ground in the field.	
Line-Voltage Output Relay Terminal Blocks (on Control and Expansion Modules with Relay Output)	LNC1 LNC2	Connects equipment control circuit to the Line-voltage Normally Closed (LNC) contact on the SPDT relay. LNC2 terminals are (only) on control and expansion modules with two output relays.	28 AWG to 14 AWG 0.3 mm <sup>2</sup> to 1.5 mm <sup>2</sup>
	LNO1 LNO2	Connects equipment control circuit to the Line-voltage Normally Open (LNO) contact on the SPDT relay. LNO2 terminals are (only) on control and expansion modules with two output relays.	
	LC1 LC2	Connects line power (equipment control circuit power) to the Line-voltage Common (LC) on the SPDT relay. LC2 terminals are (only) on control and expansion modules with two output relays.	
Low-Voltage Analog Output Terminal Block (on Control and Expansion Modules with Analog Outputs)	AO1 AO2	In conjunction with the COM terminal, provides a self-detecting analog output signal; either 0-10 VDC or 4-20 mA.	28 AWG to 16 AWG 0.3 mm <sup>2</sup> to 1.0 mm <sup>2</sup>
	COM	In conjunction with the AO1 or AO2 terminal, provides a self-detecting analog output signal; either 0-10 VDC or 4-20 mA.	
Line-Voltage Supply Power Terminal Block (on Power Modules)	240 VAC	Left terminal is for one 240 VAC supply power lead.	22 AWG to 14 AWG 0.5 mm <sup>2</sup> to 1.5 mm <sup>2</sup>
	No Label on the Middle Terminal	Middle terminal is the Common connection for either the 120 VAC or 240 VAC supply power lead.	
	120 VAC	Right terminal is for one 120 VAC supply power lead.	

## **Wiring System 450 Sensors and Transducers**

Refer to the sensor installation instructions referenced in *Related Documentation* on page 3 for information on wiring System 450 compatible control sensors.

A 1000 ohm resistor is included with all control modules for use on control systems that use DPT-2650 type low differential pressure transducers and H67Sx-x type humidity sensors.

**IMPORTANT:** When using a DPT-2650 type low differential pressure transducer or an H67Sx humidity sensor in a System 450 control system, you **must** connect a 1000 ohm resistor (included with the control module) between the OUT and COM terminals on the transducer or sensor. Failure to install this resistor limits the sensor range, which results in inaccurate air pressure or humidity readings and inaccurate control.

## **Setting Up a System 450 Control System**

After assembling the modules, your System 450 control system is ready to connect to power and to be set up in the control module UI.

**Note:** You can power on and set up a System 450 control system (in the control module UI) before installing the module assembly or wiring the sensors and outputs.

## **Determining Output Numbers and Output Types**

After all of the modules in your control system are properly assembled and (each time) power is supplied to the module assembly, the control module automatically polls all of the modules in the assembly, assigns output numbers, and determines output types and their order in the assembly.

The control module assigns a sequential **output number** to each output in the module assembly, starting with the output farthest to the left in the control module, which is assigned output number 1. Each output to the right of output 1 is assigned an output number; 2 to 9 in order of the output's physical position, left to right, in the module assembly. Zero (0) is assigned to output 10, if the control system has ten outputs. See Figure 3 for an example of output numbers in a module assembly.

The control module also determines if an output is a relay output or an analog output, and generates the appropriate status screens and set up screens in the System 450 UI for each output.

**IMPORTANT:** Do not change the module positions after a System 450 control system is assembled, powered, and set up in the System 450 User Interface (UI). System 450 control logic is set up in the UI according to the sensor type, output type, and output number. Changing the module positions in an module assembly that is already set up in the UI, changes the output numbers and default setup values for the outputs, which often requires setting up the entire control system again in the UI.

## Accessing and Navigating the User Interface

System 450 control modules feature a backlit LCD and a four-button touch pad UI for monitoring system status and setting up the sensors and outputs in your control system. Figure 1 describes the UI features and functions.

During normal operation, the System 450 control module LCD displays the **Main System Status** screens. These sensor status screens scroll automatically and provide real-time status of the conditions sensed at the control sensors.

### Viewing the System Status Screens

From the Main Sensor Status screens, you can easily scroll through and view your systems status.

To scroll and view the control system status screens:

1. While the control module LCD is displaying a **Main (Sensor Status)** screen, press the Next button (repeatedly) to scroll through and display the **Sensor Status** screens and the **Output Status** screens for all sensors and outputs set up in your control system (Figure 9).

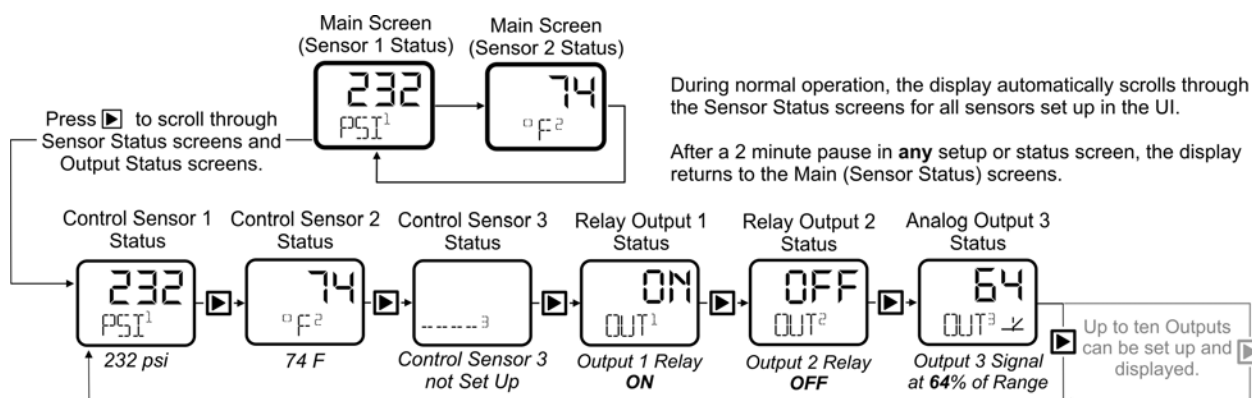

**Figure 9: Main (Sensor Status) Screens and Output Status Screens Example**

**Note:** When scrolling through the status screens, a 2 minute pause in any status screen causes the control module LCD to automatically revert back to the Main screen.

### Accessing the System Setup Screens

From the Main sensor status screens, you can also access the Sensor Setup Start screen and the Output Setup Start screens.

- From the Sensor Setup Start screen, you can setup all of the sensors for your control system. (See *Setting Up the Control Sensors* on page 24 for procedures on setting up the control sensors.)
- From the Output Setup Start screens, you can set up each output point in your control system. (See *Setting Up a Relay Output* on page 25 and *Setting Up an Analog Output* on page 27 for procedure on setting up outputs.)

To access and navigate the System 450 Setup Start screens:

1. In the **Main (Sensor Status)** screen, press the Up and Down buttons simultaneously and hold for 5 seconds. The **Sensor Setup Start** screen (**SENS**) appears (Figure 10).

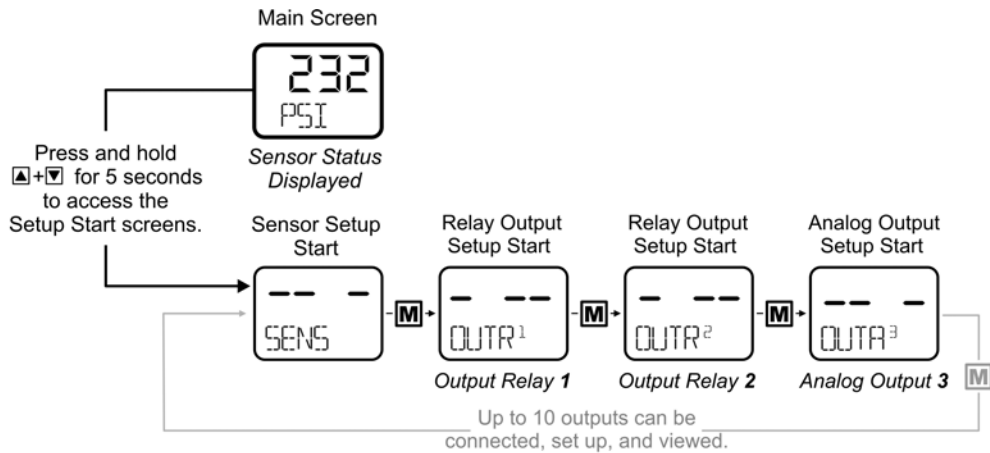

Press **M** to scroll through the Sensor Setup Start screens and all of the Analog and Relay Output Setup Start screens.  
Press **▶** in the Sensor Setup Start screen to scroll through the Sensor Setup screens.  
Press **▶** in any Output Setup Start screen to scroll through that output's set up screens.  
Press **▲+▼** simultaneously in any Setup Start screen to return to the Main Screen.

**Figure 10: Accessing the Output Status Start, Sensor Type Selection Start, and Output Setup Start Screens in the System 450 UI**

2. Press the Menu button (repeatedly) to scroll through and access the **Output Setup Start** screens for all of the outputs in your control system.

**Note:** All Setup Start screens have four blinking dashes in the setup value fields (Figure 10). Values cannot be selected in the setup value fields in the Setup Start screens.

3. Depending on the Setup Start screen that is displayed, press the Next button:
  - in the **Sensor Setup Start** screen to go the **Select Sensor 1 Type** screen (**Sn-1**) and set up the sensors in your control system. (See *Setting Up the Control Sensors* for procedures on setting up the sensors.)
  - in any **Output Setup Start** screen to go to the first output setup screen for the output. (See *Setting Up a Relay Output* or *Setting Up an Analog Output* for the procedures for setting up outputs.)

**Note:** You **must** set up the control sensors in the System 450 UI before you can set up the outputs in the UI.

## Setting Up the Control Sensors

To set up the control sensors in your System 450 control system, you must select the correct Sensor Type for each sensor. You can also select a temperature offset value for any temperature sensor that is set up in your control system.

The Sensor Type you select for a control sensor automatically determines the condition type (temperature, pressure, or humidity), unit of measurement, minimum differential, setup value ranges, and default setup values for each output in your control system that references the control sensor.

**Note:** For a System 450 control system to operate properly, the correct sensor or transducer model must be wired to the correct sensor input terminals on the control module and the the correct Sensor Type must be selected in the associated **Select Sensor Type** screen in the System 450 UI.

See Table 3 on page 12 for System 450 Sensor Types and their associated values and settings.

See Table 9, Table 10, Table 11, and Table 12 in *Repair and Replacement* on page 36 for complete product code numbers and ordering information for System 450 compatible sensors and transducers.

System 450 allows you to select an offset for each temperature sensor in your control system. Whenever you select the °F or °C Sensor Type for a sensor, a **Select Temperature Offset** screen appears after the **Select Sensor 3 Type** screen for each temperature sensor in your control system:

- Sensor Type °F enables an offset of up to +/- 5°F in 1 degree increments.
- Sensor Type °C enables an offset of up to +/- 2.5°C in 0.5 degree increments.

The temperature offset adjusts the displayed temperature value by the offset value. For example, if the displayed value is 72(°F) without an offset, a -2(°F) offset adjusts the displayed value to 70(°F).

To set up the Sensor Type for the control sensors and the temperature offset for a temperature sensor:

1. Access the System 450 UI and navigate to the **Sensor Setup Start** screen (Figure 11)
2. In the **Sensor Setup Start** screen, press Next to go to the **Select Sensor 1 Type** screen (**Sn-1**).
3. In the **Select Sensor 1 Type** screen, press the Up or Down button to scroll through the Sensor Types. When the desired Sensor Type is displayed (blinking), press the Next button to save the Sensor Type selection and go to the **Select Sensor 2 Type** screen (**Sn-2**).
4. Repeat Step 3 in the **Select Sensor 2 Type** screen and **Select Sensor 3 Type** screen if your control system uses a second or third control sensor.

After you have selected the correct Sensor Type for each sensor in your control system, the control sensors are set up in the UI and can be referenced by the outputs that you set up in the system.

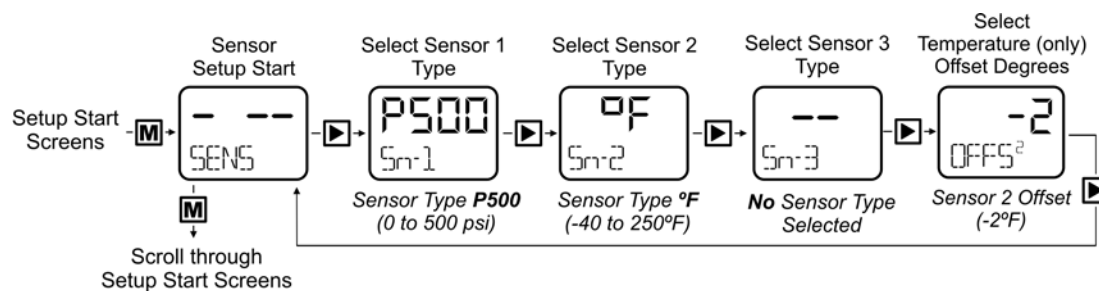

**Note:** Whenever you select the °F or °C Sensor Type for a sensor (Sn-1, Sn-2, or Sn-3), a **Select Temperature Offset** screen is displayed after the **Select Sensor 3 Type** screen for each temperature sensor in your control system. Select the desired temperature offset for a temperature sensor by pressing ▲ or ▼.

**Figure 11: Sensor Setup Start, Select Sensor Type, and Select Temperature Offset Screens**

5. If a temperature Sensor Type (°F or °C) is selected for a sensor in your control system, a **Select Temperature Offset** screen is displayed after the **Select Sensor 3 Type** screen (for each temperature sensor in your control system). Select the desired temperature offset by pressing the Up or Down button. Press the Next button to save the offset value and go to the next screen.
6. After all of the sensors are set up:
  - Press the Next button to go to the **Sensor Setup Start** screen; then press the Menu button to scroll through the output setup start screens and set up the outputs in your control system. (See [Setting Up a Relay Output](#) and [Setting Up an Analog Output](#) for procedures on setting up outputs.)
  - Allow the UI to remain dormant for 2 minutes and return to the Main screen.

### Setting Up a Relay Output

Relay Outputs provide single and multiple stage On/Off control to controlled equipment. When you supply power to a module assembly, the control module polls all of the connected modules, detects any relay outputs, and then assigns an output number and enables a **Relay Output Setup Start** screen for each relay output detected (Figure 12). See [Relay Outputs](#) on page 8 for more information.

**Note:** The condition (temperature, pressure, or humidity), unit of measurement, minimum differential value, default setup values, condition value ranges available in the output setup screens are determined by the Sensor Type of the control sensor that you select for the output. See Table 3 on page 12 for more information on Sensor Types and their associated values and ranges.

The **Relay ON** screen and **Relay OFF** screen allow you to select the condition values at which the relay turns On and turns Off. The first time you access the Relay ON and Relay OFF screens, the default ON and OFF values appear.

Selecting an ON value less than the OFF value (ON < OFF) turns the relay On when the condition value decreases (which is the typical heating mode in temperature applications and referred to as reverse-acting On/Off control).

Selecting an ON value greater than the OFF value (ON > OFF) turns the relay On when the condition value increases (which is the typical cooling mode in temperature applications and referred to as direct-acting On/Off control).

The **minimum differential** value for the condition is determined by the Sensor Type of the control sensor that an output references. The minimum differential is fixed and is automatically enforced in the setup UI when you select ON and OFF values; the condition values within the minimum differential range are not available to select.

The **Minimum Relay ON Time** and **Minimum Relay OFF Time** screens provide anti-short-cycling control for system equipment by allowing you to delay the shutdown or start-up for up to 300 seconds (5 minutes) after the ON or OFF value is reached.

The **Sensor Failure Mode** screen allows you to select whether the output relay is On or Off if the referenced control sensor encounters a sensor or wiring failure.

To set up a relay output:

1. Access the System 450 UI and navigate to the desired **Relay Output Setup Start** screen (Figure 12). (See [Accessing and Navigating the User Interface](#) on page 22.)

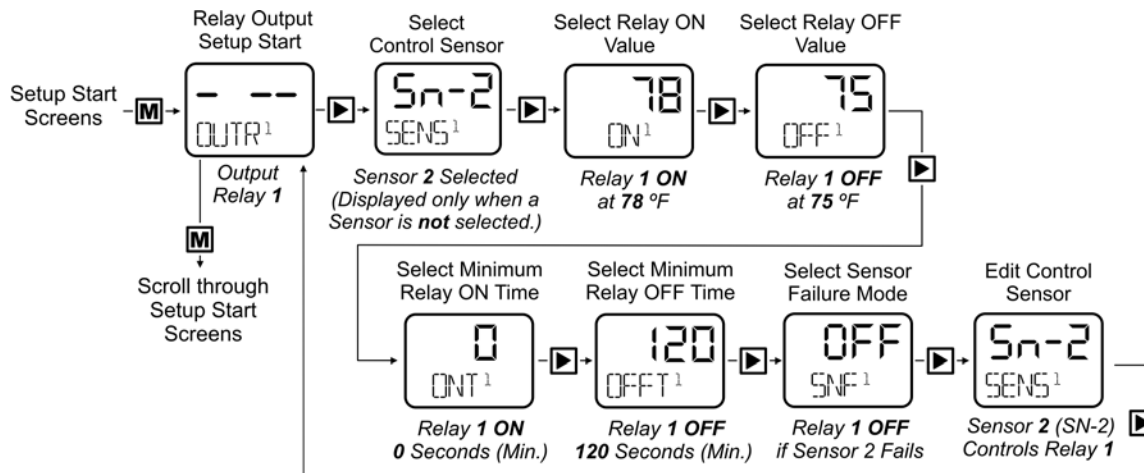

Press the Next button in the **Relay Output Setup Start** screen to scroll through the setup screens. Press the Menu button in the **Relay Output Setup Start** screen to scroll through the setup start screens.

**Note:** The **Select Control Sensor** screen appears **only** if a control sensor is **not** selected for an output. If a control sensor is already selected for an output, you can select a different sensor for the output in the **Edit Control Sensor** screen. But if you select a different sensor you must set up the output again for the (different) sensor that you selected.

**Figure 12: Relay Output Setup Start Screen and Setup Screen Flow**

2. In the **Relay Output Setup Start** screen, press the Next button to go to:
  - the **Select Control Sensor** screen, if a control sensor is **not** selected for the output. Go to Step 3.
  - the **Relay ON Value** screen, if a control sensor is already selected for the output. Go to Step 4.

## ***preliminary - this information may change***

3. In the **Select Control Sensor** screen, press the Up or Down button to select the control sensor (Sn-1, Sn-2, or Sn-3) that the output references. Press the Next button to save the sensor selection and go to the **Relay ON Value** screen.
4. In the **Relay ON Value** screen, press the Up or Down button to select the temperature, pressure, or humidity value at which the relay goes On. Press the Next button to save the ON value and go to the **Relay OFF Value** screen.
5. In the **Relay OFF Value** screen, press the Up or Down button to select the temperature, pressure, or humidity value at which the relay goes Off. Press the Next button to save the OFF value and go to the **Minimum Relay ON Time** screen.
6. In the **Minimum Relay ON Time** screen, press the Up or Down button to select the minimum number of second that the relay stays On after the Relay ON value is reached. Press the Next button to save the Minimum ON value and go to the **Minimum Relay OFF Time** screen.
7. In the **Minimum Relay OFF Time** screen, press the Up or Down button to select the minimum number of second that the relay stays Off after the Relay OFF value is reached. Press the Next button to save the Minimum OFF value and go to the **Sensor Failure Mode** screen.
8. In the **Sensor Failure Mode** screen, press the Up or Down button to select whether the output relay stays On or Off when a sensor failure is detected. Press the Next button to save the Sensor Failure Mode value and go to the **Edit Control Sensor** screen.
9. In the **Edit Control Sensor** screen:
  - If the displayed control sensor (Sn-1, Sn-2, or Sn-3) is the correct control sensor for the output relay, the output set up is complete. Press the next button to go to the **Relay Output Setup Start** screen
  - If the displayed control sensor (Sn-1, Sn-2, or Sn-3) is not the correct control sensor for the output relay, press the Up or Down button to select the correct control sensor. Press the Next button to save the new control sensor selection and go to the **Relay ON Value** screen. Repeat Step 4 through Step 9 for the new control sensor.

The relay output is set up and saved in the control module. You can navigate to the next Output Setup Start screen (by pressing the Menu button) to set up the next output, or if you have completed your control system setup, press the Up and Down arrows simultaneously to return to the Main screens.

### **Setting Up an Analog Output**

Analog Outputs provide proportional analog control signals to controlled equipment based on the sensed conditions. When you supply power to a module assembly, the control module polls all of the connected modules, detects any analog outputs and then assigns an output number and enables an **Analog Output Setup Start** screen for each analog output detected (Figure 15). See [\*Analog Outputs\*](#) on page 8 for more information.

**Note:** The condition (temperature, pressure, or humidity), unit of measurement, minimum differential value, default setup values, condition value ranges available in the output setup screens are determined by the Sensor Type of the control sensor that you select for the output. See Table 3 on page 12 for more information on Sensor Types and their associated values and ranges.

The **Setpoint (SP)** and **End Point (EP)** screens allow you to set up a proportional band (or throttling range) for the control loops in your controlled system. The **Output at Setpoint (OSP)** and **Output at End Point (OEP)** screens allow you to select the output signal strength (as a percentage of the total signal strength range) that an analog output sends to the controlled equipment at Setpoint and End Point.

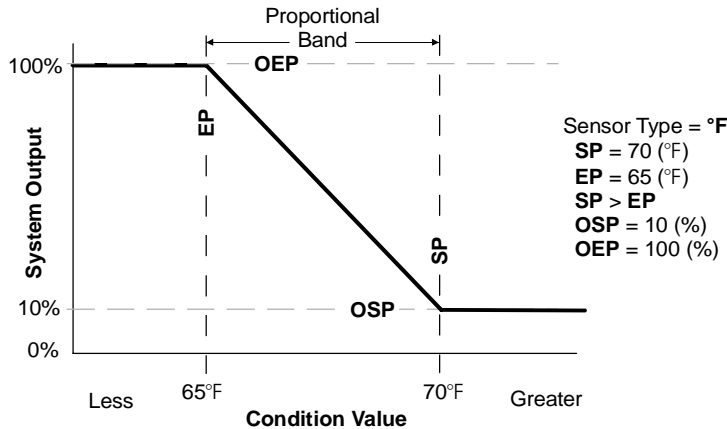

**Figure 13: Relationship Between Setpoint, End Point, Output at Setpoint, and Output at End Point for an Analog Output That Controls Room Heating**

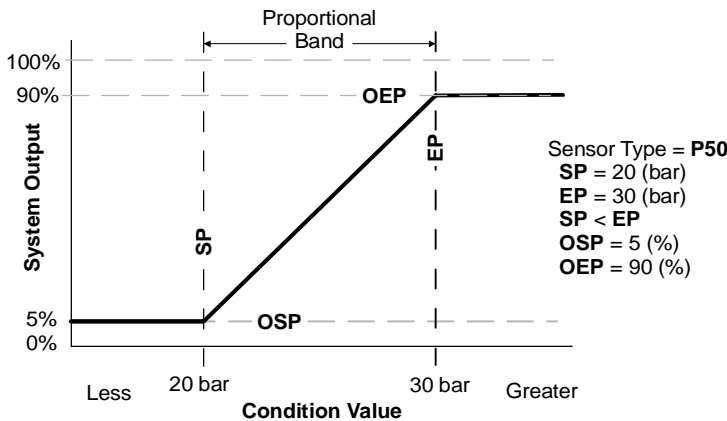

**Figure 14: Relationship Between Setpoint, End Point, Output at Setpoint, and Output at End Point for an Analog Output That Controls Condenser Fan Speed**

The relationship between these four setup values (SP, EP, OSP, and OEP) determines the analog output's proportional control action, which is indicated on the control module LCD by the control ramp indicator. See *Direct and Reverse Control Actions* on page 9 for more information.

The **Integration Constant (I-C)** screen allows you to select an integration constant for the analog signal. Selecting an integration constant (other than 0) enables proportional plus integral control action, which in many applications can drive the condition closer to Setpoint (than proportional-only control action). See *Proportional Plus Integral Control and Integration Constants* on page 10 for more information. See *Determining the Integration Constant for an Analog Output* on page 31 for procedures on determining and testing integration constants.

The **Sensor Failure Mode (SNF)** screen allows you to select whether the analog output signal is Off or maintained at minimum strength, at maximum strength or at the last valid strength value when a sensor failure is detected.

To set up an analog output:

1. Access the System 450 UI and navigate to the desired **Analog Output Setup Start** screen (Figure 15). (See *Accessing and Navigating the User Interface* on page 22.)

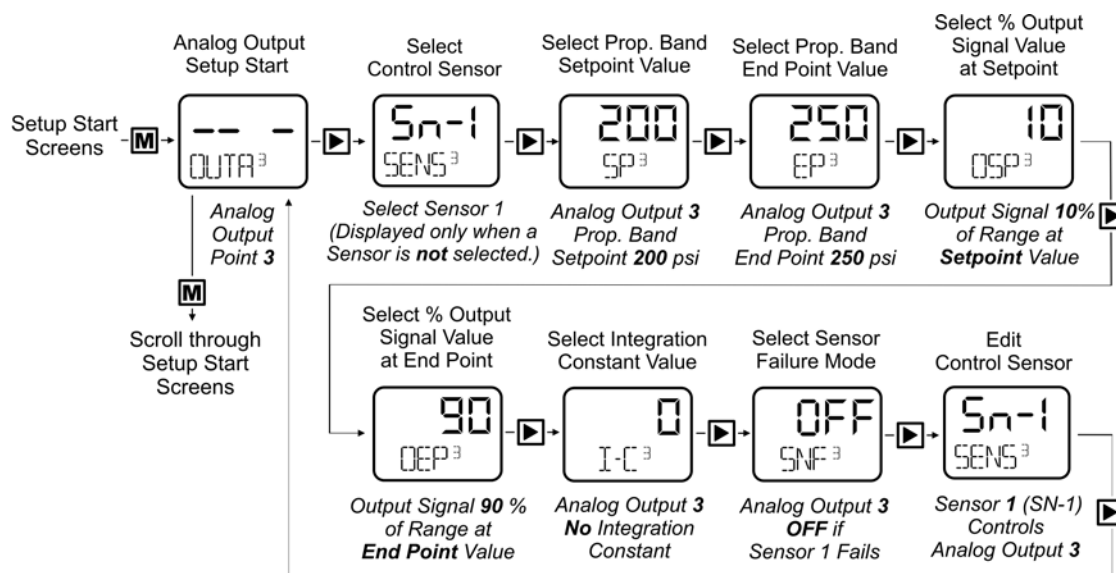

Press the Next button in the **Analog Output Setup Start** screen to scroll through the setup screens.  
Press the Menu button in the **Analog Output Setup Start** screen to scroll through the setup start screens.

**Note:** The **Select Control Sensor** screen appears **only** if a control sensor is not selected for an output. If a control sensor is already selected for an output, you can select a different sensor for the output in the **Edit Control Sensor** screen. But if you select a different sensor you must set up the output again for the (different) sensor that you selected.

**Figure 15: Analog Output Setup Start Screen and Setup Screen Flow**

2. In the **Analog Output Setup Start** screen, press the Next button to go to:
  - the **Select Control Sensor** screen (only if a control sensor is **not** selected for the output). Go to Step 3.
  - the **Setpoint Value** screen (only if a control sensor is already selected for the output). Go to Step 4.

3. In the **Select Control Sensor** screen, press the Up or Down button to select the control sensor (Sn-1, Sn-2, or Sn-3) that the output references. Press the Next button to save the sensor selection and go to the **Select Setpoint Value** screen.
4. In the **Setpoint Value** screen (SP), press the Up or Down button to select the Setpoint value. (The controlled system drives towards Setpoint and away from End Point, which together define the proportional band for the analog output.) Press the Next button to save the Setpoint value and go to the **End Point Value** screen.
5. In the **End Point Value** screen (EP), press the Up or Down button to select the End Point value. (The controlled system drives away from End Point towards Setpoint, which together define the proportional band for the analog output.) Press the Next button to save the End Point value and go to the **Output Signal Strength at Setpoint** screen.
6. In the **Output Signal Strength at Setpoint** screen (OSP), press the Up or Down button to select the value (in percent of the total output signal range 0-100%) that drives the controlled equipment to the lowest target output capacity or Off. Press the Next button to save the displayed OSP value and go to the **Output Signal Strength at End Point** screen.
7. In the **Output Signal Strength at End Point** screen (OEP), press the Up or Down button to select the value (in percent of the total output signal range 0-100%) that drives the controlled equipment to the highest target output capacity or the maximum output capacity. Press the Next button to save the displayed OEP value and go to the **Integration Constant** screen.
8. In the **Integration Constant** screen (I-C), press the Up or Down button to select the I-C value for the analog output. (See *Determining the Integration Constant for an Analog Output* for more information.) Press the Next button to save the displayed I-C value and go to the **Sensor Failure Mode** screen.
9. In the **Sensor Failure Mode** screen (SNF), press the Up or Down button to select whether the analog output signal continues to be output either at **MIN** (minimum strength), **MAX** (maximum strength) or **HOLD** (hold output signal strength at last valid value) when a failure of the referenced control sensor is detected. Press the Next button to save the displayed SNF value and go to the **Edit Control Sensor** screen.
10. In the **Edit Control Sensor** screen you can change the control sensor that the output currently references:
  - If the displayed control sensor (Sn-1, Sn-2, or Sn-3) is the correct control sensor for the output relay, the output set up is complete. Press the next button to go to the **Analog Output Setup Start** screen
  - If the displayed control sensor (Sn-1, Sn-2, or Sn-3) is not the correct control sensor for the output relay, press the Up or Down button to select the correct control sensor. Press the Next button to save the new control sensor selection and go to the **Analog Setpoint Value** screen. Repeat Step 4 through Step 9 for the new control sensor.

11. Press the Menu button to return to the **Analog Output Setup Start** screen.

The analog output is set up and saved in control module. You can navigate to the next Output Setup Start screen to set up the next output, or if you have completed your control system setup, press the Up and Down arrows simultaneously to return to the Main screens.

### **Determining the Integration Constant for an Analog Output**

The default Integration Constant (I-C) setting for analog outputs is 0 (zero) or no integration constant. An I-C setting of 0 provides a proportional-only analog signal. Many applications do not require you to change this default setting. See *Proportional Plus Integral Control and Integration Constants* on page 10 for more information.

If you want to apply proportional plus integral to a control loop in your controlled system, here are two methods of determining the best I-C setting for the analog output that controls the loop.

**Note:** Both of the following methods for determining an I-C setting require you to install, setup, and operate the control loop in your controlled system under a variety of typical load conditions and observe the response to load changes and different I-C settings.

#### ***Testing the Slowest to Fastest Time Integral to Determine I-C Setting***

One method of determining the best I-C setting for a control loop is to observe the controlled system's operation at the slowest time integral (I-C setting of 1) and then increase the I-C setting one step at a time to determine the best setting.

To determine the best I-C setting for a analog output by testing slowest to fastest time integral:

1. Set up the System 450 control loop for proportional-only control (I-C setting of 0 [zero]), power the controlled system on under typical/steady load conditions, and allow the system to stabilize at a control point somewhere in the proportional band between the Setpoint and End Point values.
2. After the controlled system has stabilized at a control point, set the integration constant to the slowest time integral (I-C setting of 1) and observe the control point to see if it stabilizes closer to the selected Setpoint.
  - If the control point overshoots the Setpoint go to Step 3.
  - If the control point stabilizes closer to Setpoint but does not overshoot Setpoint, set the integration constant to the next (faster) time integral and then observe the control point to see if it stabilizes closer to the selected Setpoint.

If the control point does not overshoot Setpoint at new I-C setting, continue to increase the setting and observe the system until the control point overshoots the Setpoint, then go to Step 3.

3. When the control point overshoots Setpoint, continue to observe the control point:

## ***preliminary - this information may change***

- If the control point drifts past Setpoint, reverses, and then drifts back towards Setpoint and stabilizes at or near Setpoint, go to Step 4
  - If the control point drives significantly beyond Setpoints, then reverses quickly, drives back past Setpoint, and continues oscillating significantly above and below Setpoint, reset the I-C setting to the previous (slower) time integral and go to Step 4.
4. When the control point stabilizes near Setpoint or drift slightly above and below Setpoint, operate the control loop under a variety of load conditions, including maximum load condition:
- If the control point drives past Setpoint and begins to oscillate significantly above and below Setpoint, reset the I-C setting to the previous (slower) time integral and repeat Step 3.
  - If the control point drifts to or past Setpoint and stabilizes near Setpoint, the current I-C setting for your control loop is correct.

Continue to observe the controlled system until you are sure that the system control point will stabilize somewhere near Setpoint and not oscillate under all load conditions.

### ***Using the Response Time to a Step Change to Determine the I-C Setting***

Another method for determining the best I-C setting for a System 450 control loop is to temporarily create a step change that shifts the proportional band in your controlled system away from the original/desired proportional band. Then measure the (first response) time it takes for your controlled system to drive to and stabilize at the shifted control point, then shift (step change) the proportional band back to original and measure the (second response) time that it take to return to the original control point.

You need a digital voltmeter set to VDC to perform this procedure.

To determine the best I-C setting for a control loop using:

1. Set up the System 450 analog output for proportional-only control (I-C setting of 0 [zero]), power your controlled system on, operate the system under steady load conditions, and allow the control loop to stabilize at a control point within the proportional band between the selected Setpoint and End Point values.
2. Connect a digital volt-meter across the analog output terminals to measure VDC signal strength changes. Measure and record the signal strength voltage at this (original) stable control point.
3. Change the Setpoint and End Point values to shift (step change) the proportional band 25% away from the original proportional band; the VDC signal rises (or drops) immediately and significantly in response to the proportional band shift. Begin timing the response (to the first step change) at this voltage rise (or drop).

**Note:** The direction of the voltage changes (rise or drop) is dependent on whether the analog output is set up as a direct-acting or reverse-acting output signal. These instructions refer to the room heating application example shown in Figure 16.

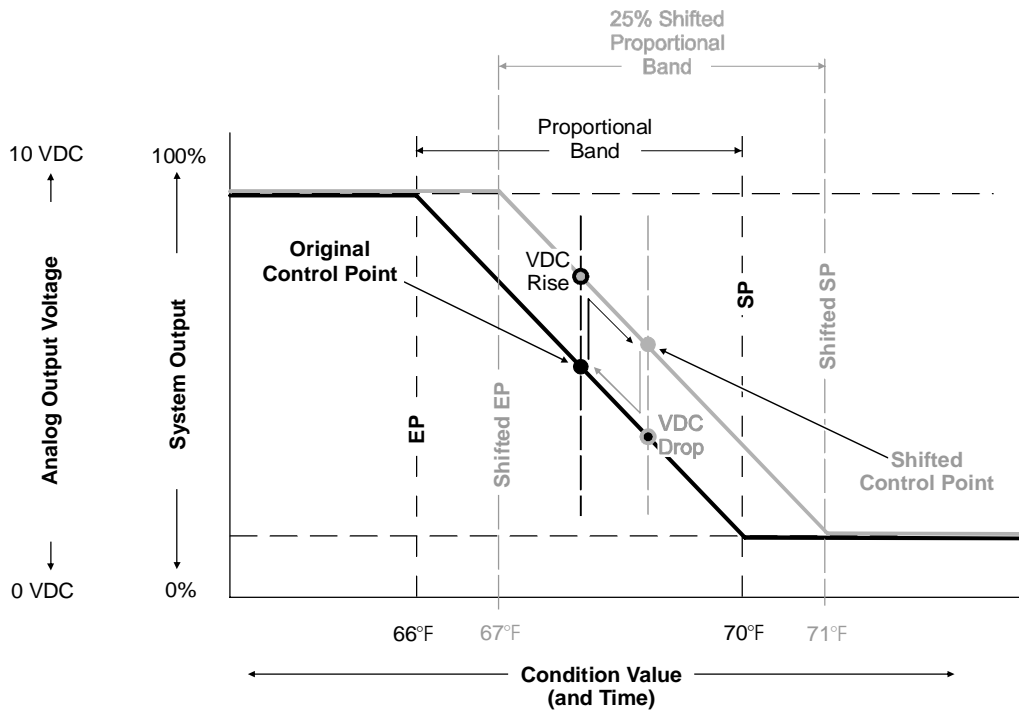

Measure the (first response) time that it takes for the controlled system to drive from the original control point to the shifted control point and then measure the (second response) time for the system to drive from the shifted control point back to the original control point. Use the slower response to determine the proper I-C.

**Figure 16: Graph Showing Temporary Proportional Band and Control Point Shifts Used to Measure Response Time in a Heating Application**

4. Observe the system response and record the time it takes for the measured voltage to drive to and stabilize at the shifted control point in the shifted proportional band. (Typically the shifted control point voltage is slightly higher [or lower] than the original control point voltage.)
5. With the controlled system stabilized at the shifted control point, return the Setpoint and End Point values shift (step change) back to the original proportional band. The signal VDC drops (or rises) immediately and significantly in response to the proportional band shift back to original. Begin timing the response (to the second step change) at this voltage drop (or rise).
6. Observe the system response and record the time it takes for the measured voltage to drive back to and stabilize at original control point (voltage) in the original proportional band.

**Note:** In many applications, the response time away from the original control point to the shifted control point is different from the response time of the shifted control point back to the original control point, depending on a variety of factors such as system load and system output. Choose the slower of the two measured response times to determine the I-C setting for your application.

7. Use the slower of the two measured response times and the following table to determine which integration constant (I-C setting) to set on the control and test first.

**Table 5: Response Times, Reset Rates, and Integration Constants**

<b>Slowest Measured Response Time for Control Point Shift</b>	<b>Select This Integration Constant (I-C) Value for the Analog Output</b>	<b>Estimated Total Reset Rate for Integration Constant</b>
<b>N/A</b>	0	No reset rate
<b>10 to 15 minutes</b>	1	1 hour (3,600 seconds)
<b>6 to 10 minutes</b>	2	30 minutes (1,800 seconds)
<b>3 to 6 minutes</b>	3	15 minutes (900 seconds)
<b>1 to 3 minutes</b>	4	5 minutes (300 seconds)
<b>30 to 60 seconds</b>	5	2 minutes (120 seconds)
<b>10 to 30 seconds</b>	6	1 minute (60 seconds)

8. Set the integration constant to the determined I-C setting. Operate and observe the controlled system at a variety of load conditions to determine if the system is stable at the determined I-C setting over the entire output range of the controlled system.

## Troubleshooting System 450 Control Systems

System 450 control modules display error messages when the module detects a sensor, sensor wiring, sensor power, or power supply failure.

Table 6 shows the System 450 error messages that may be displayed, and provides possible causes for the error messages and the solutions for remedying the errors.

**Table 6: System 450 Control System Error Messages**

<b>Problem/Symptom</b>	<b>Possible Cause</b>	<b>Solution</b>
<b>Sensor failure is detected and &lt; SNF &gt; is displayed (instead of a value).</b>  <b>Outputs that reference the failed sensor are operating in the Sensor Failure Modes selected for the Output at setup.</b>	Sensor, sensor wiring, or sensor connections may have failed open or closed	Check and verify integrity of sensor wiring and connections. Measure the voltage between the sensor terminal (S1, S2, or S3) and the low-voltage common (C) terminal (with the sensor connected). Refer to Table 7 for the sensor's expected voltage range. If the sensor wiring and sensor connections are good, replace the sensor and recheck the voltage.
<b>Sensor power drops below 4.75 VDC and &lt; Err 5V &gt; is displayed (instead of a value).</b>  <b>All Outputs are Off.</b>	The +5 VDC output is out of the specified range; the output may be shorted to ground at the wiring or the sensor may have failed.	Check the voltage between the +5 VDC (5V) terminal and any one of the common (C) terminals. The specified voltage range is +4.8 to +5.2 VDC. If the specified voltage is out of range, check the primary supply voltage. (See solution below.) If the primary supply voltage is in range, remove all wiring connection to the 5V terminal and check the voltage between 5V and any C terminal. If the voltage is in range (+4.8 to +5.2 VDC), reconnect each sensor one at a time to determine which sensor is causing the voltage drop. Replace the faulty sensor and recheck the output voltage
<b>Supply power failure is detected and &lt; Err PWR &gt; is displayed (instead of a value).</b>  <b>All Outputs are Off.</b>	Supply power failure; supply voltage too low voltage or too high.	Check the supply voltage to the C450 power module. The measured voltage must be between 100 and 130 VAC at the 120 VAC terminals, or between 200 and 260 VAC at the 240 VAC terminals. If the System 450 control system is powered by an external 24 VAC power supply, the voltage must be between 20 and 30 VAC. Bring the supply into range.

### Specified Voltage Ranges for Sensors

Table 7 provides the specified operating voltage range for System 450 sensors. To determine if a sensor is operating in the specified range, measure the voltage between the sensor's terminal connections at the System 450 control module (the S1, S2, or S3 terminal and one of the C terminals).

If the voltage is out of the specified range, check the sensor wiring for shorted or open circuits. Repair or replace wiring as needed. If the wiring appears to be in good condition, replace the sensor and retest the voltage and operation.

**Table 7: Specified Voltage Ranges Between Sensor Terminals**

Connected Sensor	Specified Voltage Range Measured Between a Sensor Terminal (S1, S2, or S3) and a Common Terminal (C)
A99B Type Temperature Sensors	0.24 to 0.67 VDC
HE-67xx Humidity Sensor	0.35 to 5.0 VDC
DPT-2650 Low-Pressure Differential Sensor	0.35 to 5.0 VDC
P499 Series Electronic Pressure Transducer	0.5 to 4.5 VDC

## Repair and Replacement

Table 8 provides ordering information for the currently available System 450 Series modules.

Table 9, Table 10, Table 11, and Table 12 provides ordering information for the System 450 compatible sensors. For more information on installing System 450 compatible sensors, see *Related Documentation* on page 3.

**Table 8: System 450 Module Ordering Information**

Product Code Number	Product Description
<b>C450CBN-1</b>	Control Module <sup>1</sup> with LCD, Four-Button Touchpad UI, and Relay Output; Provides one relay output (SPDT line-voltage relay) for On/Off control.
<b>C450CCN-1</b>	Control Module <sup>1</sup> with LCD, Four-Button Touchpad UI, and Relay Output; Provides two relay outputs (SPDT line-voltage relays) for On/Off control.
Release Fall 2009	Control Module <sup>1</sup> with LCD, Four-Button Touchpad UI, and Analog Output; Provides one analog output (0-10 VDC or 4-20 mA self-selecting signal) for proportional control.
Release Fall 2009	Control Module <sup>1</sup> with LCD and Four-Button Touchpad UI, and Analog Output; Provides two analog outputs (0-10 VDC or 4-20 mA self-selecting signals) for proportional control.
<b>C450SBN-1</b>	Relay Output Expansion Module; Provides one relay output (SPDT line-voltage relay) for On/Off control.
<b>C450SCN-1</b>	Relay Output Expansion Module; Provides two relay outputs (SPDT line-voltage relays) for On/Off control.
Release Fall 2009	Analog Output Expansion Module; Provides one analog output (0-10 VDC or 4-20 mA self-selecting signal) for proportional control.
Release Fall 2009	Analog Output Expansion Module; Provides two analog outputs (0-10 VDC or 4-20 mA self-selecting signals) for proportional control.
<b>C450YNN-1</b>	Power Module; Provides 24 V to System 450 Module Assembly; 120 VAC or 240 VAC supply power input terminals

1. All System 450 control modules can control both relay and analog outputs in a control system.

**Table 9: System 450 Compatible A99B Temperature Sensors  
Ordering Information**

<b>Product Code Number</b>	<b>Product Description</b>
<b>A99BA-200C</b>	PTC Silicon Sensor with Shielded Cable; Cable length (2 m) 6-1/2 ft Sensor Temperature Range: -40 to 120°C (-40 to 250°F) <b>Note:</b> Cable jacket temperature range -40 to 100°C (-40 to 212°F)
<b>A99BB-25C</b>	PTC Silicon Sensor with PVC Cable; Cable length (0.25 m) 9-3/4 in. Sensor Temperature Range: -40 to 120°C (-40 to 250°F) <b>Note:</b> Cable jacket temperature range -40 to 100°C (-40 to 212°F)
<b>A99BB-200C</b>	PTC Silicon Sensor with PVC Cable; Cable length (2 m) 6-1/2 ft Sensor Temperature Range: -40 to 120°C (-40 to 250°F) <b>Note:</b> Cable jacket temperature range -40 to 100°C (-40 to 212°F)
<b>A99BB-300C</b>	PTC Silicon Sensor with PVC Cable; Cable length (3 m) 9-3/4 ft Sensor Temperature Range: -40 to 120°C (-40 to 250°F) <b>Note:</b> Cable jacket temperature range -40 to 100°C (-40 to 212°F)
<b>A99BB-500C</b>	PTC Silicon Sensor with PVC Cable; Cable length (5 m) 16-3/8 ft Sensor Temperature Range: -40 to 120°C (-40 to 250°F) <b>Note:</b> Cable jacket temperature range -40 to 100°C (-40 to 212°F)
<b>A99BB-600C</b>	PTC Silicon Sensor with PVC Cable; Cable length (6 m) 19-1/2 ft Sensor Temperature Range: -40 to 120°C (-40 to 250°F) <b>Note:</b> Cable jacket temperature range -40 to 100°C (-40 to 212°F)
<b>A99BC-25C</b>	PTC Silicon Sensor with High Temperature Silicon Cable; Cable length (0.25 m) 9-3/4 in. Sensor Temperature Range: -40 to 120°C (-40 to 250°F) Cable jacket rated for full sensor temperature range.
<b>A99BC-300C</b>	PTC Silicon Sensor with High Temperature Silicon Cable; Cable length (3 m) 9-3/4 ft Sensor Temperature Range: -40 to 120°C (-40 to 250°F) Cable jacket rated for full sensor temperature range.
<b>A99BC-1500C</b>	PTC Silicon Sensor with High Temperature Silicon Cable; Cable length (15 m) 49 ft Sensor Temperature Range: -40 to 120°C (-40 to 250°F) Cable jacket rated for full sensor temperature range.

**Table 10: System 450 Compatible Humidity Sensor with Temperature Sensor  
Ordering Information**

<b>Product Code Number</b>	<b>Product Description</b>
<b>HE67S3-0N0BT</b>	Wall Mount Humidity Sensor with A99B Type Temperature Sensor: 10 to 95% RH; -40 to 121°C (-40 to 250°F)
<b>HE67S3-0N00P</b>	Duct Mount Humidity Sensor with A99B Type Temperature Sensor: 10 to 95% RH; -40 to 121°C (-40 to 250°F)

**Table 11: System 450 Compatible Low Pressure Differential Transducer  
Ordering Information**

<b>Product Code Number</b>	<b>Product Description</b>
<b>DPT-2650-0R5D-AB</b>	Low Pressure Differential Transducer: 0 to 0.50 in.W.C.
<b>DPT-2650-010D-AB</b>	Low Pressure Differential Transducer: 0 to 10 in.W.C.

**Table 12: System 450 Compatible P499 Series Electronic Pressure Transducer and WHA-PKD3 Wire Harness Ordering Information**

<b>Product Code Number</b>	<b>Product Description</b>
<b>P499RCP-401C</b>	Electronic Pressure Transducer: -1 to 8 bar; 1/4 in. SAE 45° Flare Internal Thread (7/16-20 UNF) with Depressor (Style 47). Order WHA-PKD3 type wire harness separately.
<b>P499RCP-402C</b>	Electronic Pressure Transducer: -1 to 15 bar; 1/4 in. SAE 45° Flare Internal Thread (7/16-20 UNF) with Depressor (Style 47). Order WHA-PKD3 type wire harness separately.
<b>P499RCP-404C</b>	Electronic Pressure Transducer: 0 to 30 bar; 1/4 in. SAE 45° Flare Internal Thread (7/16-20 UNF) with Depressor (Style 47). Order WHA-PKD3 type wire harness separately.
<b>P499RCP-405C</b>	Electronic Pressure Transducer: 0 to 50 bar; 1/4 in. SAE 45° Flare Internal Thread (7/16-20 UNF) with Depressor (Style 47). Order WHA-PKD3 type wire harness separately.
<b>P499RAP-101C</b>	Electronic Pressure Transducer: 0 to 100 psi; 1/8 in.-27 NPT External Thread Style Order a WHA-PKD3 type wire harness separately.
<b>P499RAP-101K</b>	Electronic Pressure Transducer Kit: 0 to 100 psi; 1/8 in.-27 NPT External Thread Style WHA-PKD3-200C wire harness included.
<b>P499RCP-101C</b>	Electronic Pressure Transducer: 0 to 100 psi; 1/4 in. SAE 45° Flare Internal Thread (7/16-20 UNF) with Depressor (Style 47). Order WHA-PKD3 type wire harness separately.
<b>P499RCP-101K</b>	Electronic Pressure Transducer Kit: 0 to 100 psi; 1/4 in. SAE 45° Flare Internal Thread (7/16-20 UNF) with Depressor (Style 47). WHA-PKD3-200C wire harness included.
<b>P499RAP-105C</b>	Electronic Pressure Transducer: 0 to 500 psi; 1/8 in.-27 NPT External Thread Style Order WHA-PKD3 type wire harness separately.
<b>P499RAP-105K</b>	Electronic Pressure Transducer Kit: 0 to 500 psi; 1/8 in.-27 NPT External Thread Style WHA-PKD3-200C wire harness included.
<b>P499RCP-105C</b>	Electronic Pressure Transducer: 0 to 500 psi; 1/4 in. SAE 45° Flare Internal Thread (7/16-20 UNF) with Depressor (Style 47). Order WHA-PKD3 type wire harness separately.
<b>P499RCP-105K</b>	Electronic Pressure Transducer Kit: 0 to 500 psi; 1/4 in. SAE 45° Flare Internal Thread (7/16-20 UNF) with Depressor (Style 47). WHA-PKD3-200C wire harness included.
<b>P499RAP-107C</b>	Electronic Pressure Transducer: 0 to 750 psi; 1/8 in.-27 NPT External Thread Style Order WHA-PKD3 type wire harness separately.
<b>P499RAP-107K</b>	Electronic Pressure Transducer Kit: 0 to 750 psi; 1/8 in.-27 NPT External Thread Style WHA-PKD3-200C wire harness included.
<b>P499RCP-107C</b>	Electronic Pressure Transducer: 0 to 750 psi; 1/4 in. SAE 45° Flare Internal Thread (7/16-20 UNF) with Depressor (Style 47). Order WHA-PKD3 type wire harness separately.
<b>P499RCP-107K</b>	Electronic Pressure Transducer Kit: 0 to 750 psi; 1/4 in. SAE 45° Flare Internal Thread (7/16-20 UNF) with Depressor (Style 47). WHA-PKD3-200C wire harness included.
<b>WHA-PDK3-200C</b>	Plug and 3-Wire Harness for P499 Electronic Pressure Transducers: 2.0 m (6-1/2 ft) cable
<b>WHA-PDK3-400C</b>	Plug and 3-Wire Harness for P499 Electronic Pressure Transducers: 4.0 m (13 ft) cable
<b>WHA-PDK3-600C</b>	Plug and 3-Wire Harness for P499 Electronic Pressure Transducers: 6.0 m (19-5/8 ft) cable

## Technical Specifications

### C450CxN-1

<b>Product</b>	C450CxN-1: System 450 Control Module models are sensing controls and operating controls with LCD, four-button touch pad, and On/Off relay output C450CBN-1: Control Module with one SPDT output relay C450CCN-1: Control Module with two SPDT output relays									
<b>Supply Power</b>	C450-YNN-1 Power Supply Module or 24 (20-30) VAC Safety Extra-Low Voltage (SELV) (Europe) Class 2 (North America) 50/60 Hz, 10 VA minimum									
<b>Ambient Operating Conditions</b>	<b>Temperature:</b> -40 to 66°C (-40 to 150°F) <b>Humidity:</b> Up to 95% RH non condensing; Maximum Dew Point 29°C (85°F)									
<b>Ambient Shipping and Storage Conditions</b>	<b>Temperature:</b> -40 to 80°C (-40 to 176°F) <b>Humidity:</b> Up to 95% RH non condensing; Maximum Dew Point 29°C (85°F)									
<b>Input Signal</b>	0-5 VDC; 1035 ohms at 25°C (77°F) for an A99 PTC Temperature Sensor									
<b>Output Relay Contacts</b>	<b>General:</b> 1/2 HP at 120/240 VAC, SPDT <b>Specific:</b> <table border="1"><thead><tr><th>AC Motor Ratings</th><th>120 VAC</th><th>208/240 VAC</th></tr></thead><tbody><tr><td>AC Full-load Amperes:</td><td>9.8 A</td><td>4.9 A</td></tr><tr><td>AC Locked-Rotor Amperes:</td><td>58.8 A</td><td>29.4 A</td></tr></tbody></table> 10 Amperes AC Non-inductive at 24/240 VAC Pilot Duty: 125 VA at 24/240 VAC	AC Motor Ratings	120 VAC	208/240 VAC	AC Full-load Amperes:	9.8 A	4.9 A	AC Locked-Rotor Amperes:	58.8 A	29.4 A
AC Motor Ratings	120 VAC	208/240 VAC								
AC Full-load Amperes:	9.8 A	4.9 A								
AC Locked-Rotor Amperes:	58.8 A	29.4 A								
<b>Analog Input Accuracy</b>	<b>Resolution:</b> 10 bit									
<b>Control Construction</b>	Independently-mounted control, surface mounted with Lexan® 950 enclosure suitable for DIN rail mounting or direct mounting to a hard, even surface.									
<b>Dimensions (H x W x D)</b>	127 x 61 x 61 mm (5 x 2-3/8 x 2-3/8 in.)									
<b>Weight</b>	C450CBN-1: 209 gm (0.46 lb) C450CCN-1: 222 gm (0.49 lb)									
<b>Compliance</b>	<b>North America:</b> cULus Listed; UL 60730, File E27734, Vol. 1; FCC Compliant to CFR47, Part 15, Subpart B, Class B Industry Canada (IC) Compliant to Canadian ICES-003, Class B limits <b>Europe:</b> Mark: CE Compliant; Low Voltage Directive (2006/95/EC); EMC Directive (2004/108/EC); RoHS Directive (2002/95/EC); WEEE Directive (2002/96/EC) <b>Australia:</b> Mark: C-Tick Compliant (N1813)									

**preliminary - this information may change**

**C450SxN-1**

<b>Product</b>	C450SBN-1: System 450 Expansion Module with one SPDT output relay C450SCN-1: System 450 Expansion Module with two SPDT output relays									
<b>Supply Power</b>	C450YNN Power Supply Module, or 24 (20-30) VAC SELV (Europe) Class 2 (North America) 50/60 Hz, 5 VA Maximum									
<b>Ambient Operating Conditions</b>	<b>Temperature:</b> -40 to 66°C (-40 to 150°F) <b>Humidity:</b> Up to 95% RH non-condensing; Maximum Dew Point 29°C (85°F)									
<b>Ambient Shipping and Storage Conditions</b>	<b>Temperature:</b> -40 to 80°C (-40 to 176°F) <b>Humidity:</b> Up to 95% RH non-condensing; Maximum Dew Point 29°C (85°F)									
<b>Output Relay Contacts</b>	<b>General:</b> 1/2 HP at 120/240 VAC, SPDT  <b>Specific:</b> <table border="0" style="width: 100%;"> <tr> <td style="width: 50%;"><u>AC Motor Ratings</u></td> <td style="width: 25%; text-align: center;">120 VAC</td> <td style="width: 25%; text-align: center;">208/240 VAC</td> </tr> <tr> <td>AC Full-load Amperes:</td> <td style="text-align: center;">9.8 A</td> <td style="text-align: center;">4.9 A</td> </tr> <tr> <td>AC Locked-Rotor Amperes:</td> <td style="text-align: center;">58.8 A</td> <td style="text-align: center;">29.4 A</td> </tr> </table> 10 Amperes AC Non-inductive at 24/240 VAC Pilot Duty: 125 VA at 24/240 VAC	<u>AC Motor Ratings</u>	120 VAC	208/240 VAC	AC Full-load Amperes:	9.8 A	4.9 A	AC Locked-Rotor Amperes:	58.8 A	29.4 A
<u>AC Motor Ratings</u>	120 VAC	208/240 VAC								
AC Full-load Amperes:	9.8 A	4.9 A								
AC Locked-Rotor Amperes:	58.8 A	29.4 A								
<b>Enclosure Material</b>	Lexan® 950									
<b>Dimensions (H x W x D)</b>	127 x 61 x 61 mm (5 x 2-3/8 x 2-3/8 in.)									
<b>Weight</b>	C450SBN-1: 172 gm (0.38 lb) C450SCN-1: 186 gm (0.41 lb)									
<b>Compliance</b>	<b>North America:</b> cULus Listed; UL 60730, File E27734, Vol. 1; FCC Compliant to CFR47, Part 15, Subpart B, Class B Industry Canada (IC) Compliant to Canadian ICES-003, Class B limits  <b>Europe:</b> Mark: CE Compliant; Low Voltage Directive (2006/95/EC); EMC Directive (2004/108/EC); RoHS Directive (2002/95/EC); WEEE Directive (2002/96/EC)  <b>Australia:</b> Mark: C-Tick Compliant (N1813)									

**C450YNN-1**

<b>Product</b>	C450YNN-1: System 450 Power Supply Module; 120 or 240 VAC stepdown to 24 VAC Class 2 (North America) or SELV (Europe)
<b>Supply Power</b>	110/120 VAC or 220/240 VAC at 50/60 Hz (100 mA maximum)
<b>Secondary Power</b>	24 VAC, 10 VA
<b>Ambient Operating Conditions</b>	<b>Temperature:</b> -40 to 66°C (-40 to 150°F) <b>Humidity:</b> Up to 95% RH non-condensing; Maximum Dew Point 29°C (85°F)
<b>Ambient Shipping and Storage Conditions</b>	<b>Temperature:</b> -40 to 80°C (-40 to 176°F) <b>Humidity:</b> Up to 95% RH non-condensing; Maximum Dew Point 29°C (85°F)
<b>Control Construction</b>	Independently-mounted control, surface mounted with Lexan® 950 enclosure suitable for DIN rail mounting or direct mounting to a hard, even surface.
<b>Dimensions (H x W x D)</b>	127 x 61 x 61 mm (5 x 2-3/8 x 2-3/8 in.)
<b>Weight</b>	C450YNN-1: 390 gm (0.86 lb)
<b>Compliance</b>	<b>North America:</b> cULus Listed; UL 60730, File E27734, Vol. 1; FCC Compliant to CFR47, Part 15, Subpart B, Class B Industry Canada (IC) Compliant to Canadian ICES-003, Class B limits  <b>Europe:</b> Mark: CE Compliant; Low Voltage Directive (2006/95/EC); EMC Directive (2004/108/EC); RoHS Directive (2002/95/EC); WEEE Directive (2002/96/EC)  <b>Australia:</b> Mark: C-Tick Compliant (N1813)

*The performance specifications are nominal and conform to acceptable industry standards. For application at conditions beyond these specifications, consult Johnson Controls Application Engineering at (414) 524-5535. Johnson Controls, Inc. shall not be liable for damages resulting from misapplication or misuse of its products.*

# ***preliminary - this information may change***

## **United States Emissions Compliance**

*This equipment has been tested and found to comply with the limits for a Class B digital device, pursuant to Part 15 of the FCC Rules. These limits are designed to provide reasonable protection against harmful interference in a residential installation. This equipment generates, uses and can radiate radio frequency energy and, if not installed and used in accordance with the instructions, may cause harmful interference to radio communications. However, there is no guarantee that interference will not occur in a particular installation. If this equipment does cause harmful interference to radio or television reception, which can be determined by turning the equipment off and on, the user is encouraged to try to correct the interference by one or more of the following measures:*

- Reorient or relocate the receiving antenna.
- Increase the separation between the equipment and receiver.
- Connect the equipment into an outlet on a circuit different from that to which the receiver is connected.
- Consult the dealer or an experienced radio/TV technician for help.

## **Canadian Emissions Compliance**

*This Class (B) digital apparatus meets all the requirements of the Canadian Interference-Causing Equipment Regulations.*

*Cet appareil numérique de la Classe (B) respecte toutes les exigences du Règlement sur le matériel brouilleur du Canada.*



**Building Efficiency**

507 E. Michigan Street, Milwaukee, WI 53202

*Metasys® and Johnson Controls® are registered trademarks of Johnson Controls, Inc. All other marks herein are the marks of their respective owners. © 2009 Johnson Controls, Inc.*