



techsystem

automatyka klimatyzacja wentylacja

▸ zapoznaj się z naszą ofertą

Series V47

Temperature Actuated Modulating Valves

Introduction

The V47 modulating water valves regulate the flow of water to maintain a desired temperature. The valves have a quick opening characteristic and OPEN on a temperature increase at the bulb.

The V47 temperature valves are used for heating applications. It has a heating element, this means that the bulb temperature always must be higher than that of the valve body (the power element).



Series V47
Temperature Actuated Water Regulating Valve

Feature and Benefits	
<input type="checkbox"/> Pressure balanced valve design	Setpoint is independent from water inlet pressure
<input type="checkbox"/> 3/8, 1/2, 3/4" are angled body type valves with high Kv value	Small dimensions with high flow capacity
<input type="checkbox"/> No close fitting or sliding parts in water passages	No hysteresis increase or stuck valve caused by contamination

Note

All Series V47 water regulating valves are designed for use only as operating devices. Where system closure, improper flow or loss of pressure due to valve failure can result in personal injury and/or loss of property, a separate pressure relief or safety shutoff valve, as applicable, must be added by the user.

Description

A pressure-balanced design employing rubber sealing diaphragms correctly proportioned to the valve port area, balances valve against both gradual and sudden water pressure changes, and seals water away from range spring, guides and sliding parts so these are not submerged in water where they would be subject to sedimentation and corrosion. Only five metal parts, made of corrosion resistant material, come in contact with the water. These are the valve disc holder, the disc stud, the valve seat, the valve stem, and the body.

Adjustments

The temperature at which the valve starts to open (= opening point) can be adjusted by the adjusting screw located at the top of the range spring housing. Valves may be adjusted with standard service valve wrenches or screwdrivers. (Valves are not factory set at a certain value.)

Manual flushing

Valves may be manually flushed by lifting the lower spring guide with screwdrivers at two sides of the pressure plate to open valve. This does not affect valve adjustment.

Valve size selection

The valve size can be selected by the use of:
- the diagram (see page 3).
- K_V factors and calculation formulae

Refer to the Diagram for selection of valves sizes. Carefully follow the steps as outlined below.

1. Determine the maximum water flow required and draw a horizontal line across upper half of Flow Chart through this flow (e.g. 65 l/min, see line A)
2. Determine the temperature rise above the valve opening point.
 - a. Valve closing point is the lowest temperature at which it is desired to have no flow through the valve.

- b. Valve opening point will be about 3 K above the valve closing point.
 - c. Determine the temperature the valve is to maintain.
 - d. Subtract the temperature opening point from the operating temperature. This gives the temperature rise.
3. Draw a horizontal line across lower half of Flow Chart through this value (e.g. 8 K, see line B)
4. Determine the allowable pressure drop through the valve. This is the pressure actually available to force liquid through the valve.
5. On lower half of curve, mark point on drawn-in horizontal temperature line at pressure determined in Step 4 (e.g. Δp of 2 bar, see line B). Interpolate between curves, or pick curve for nearest lower pressure drop for which curve is drawn (this gives a reserve maximum load capacity).
6. From this point draw line vertically upward until it intersects drawn-in horizontal water flow line in upper half of Flow Chart (see line C).
7. If intersection falls on a valve size curve this is the valve size.
8. If intersection falls between two curves the required valve size is the larger of the two (for given example it becomes a 1" valve).

Valve size selection by the use of the K_V factors and calculation formulae

For water:

$$K_V = \frac{Q}{\sqrt{p}}$$

$$\Delta P = \left(\frac{Q}{K_V} \right)^2$$

$$Q = K_V \cdot \sqrt{p}$$

Q = quantity of liquid (in m³/h)

ΔP = pressure drop across valve (in bar)

K_V = valve flow coefficient

The K_V factor is the quantity of 20°C water that will pass through the valve at one bar pressure drop and a valve opening which belongs by 14 K temperature rise above the valve opening point.

The following K_V values can be used:

Valve size	K_V value
3/8"	1.8
1/2"	2.7
3/4"	4.5
1"	6.5
1 1/4"	9
1 1/2"	10.5

Diagram for selecting the valve size corresponding with information on page 2

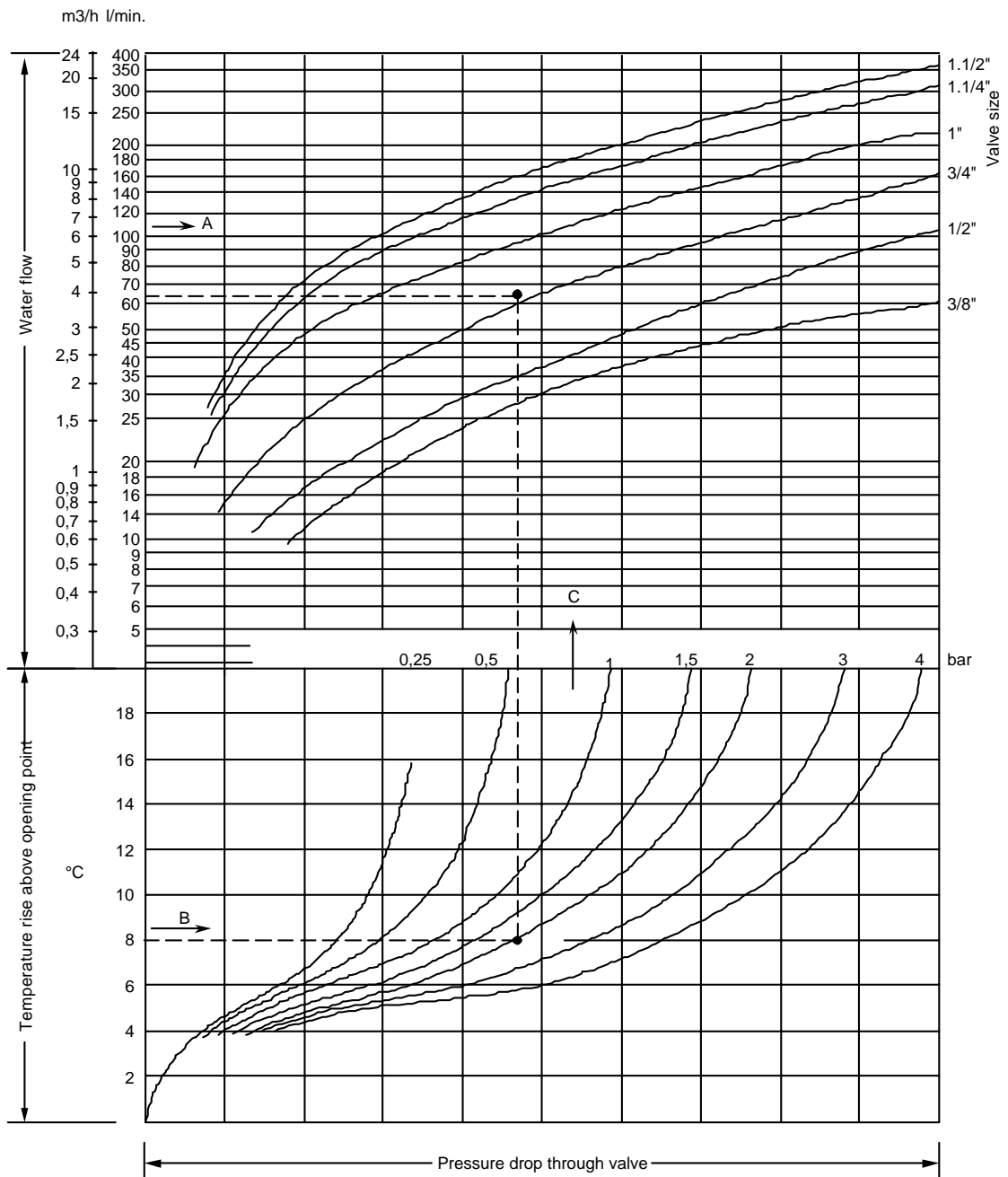

Note: $1 \text{ dm}^3/\text{s} = 3.6 \text{ m}^3/\text{h} = 15.8 \text{ U.S. gal./min.} = 13.2 \text{ U.K. gal./min.}$
 $1 \text{ bar} = 100 \text{ kPa} = 0.1 \text{ MPa} \approx 1.02 \text{ kp/cm}^2 = 1.02 \text{ at} \approx 14.5 \text{ psi.}$

Fig. 1

Repair and replacement

For type numbers of replacement power elements, renewal kits and diaphragm kits see valve selection table.

If a replacement is ordered a "repair parts and service instruction" sheet will be included in which a step by step description is given to disassemble/assemble the valve.

Bulb

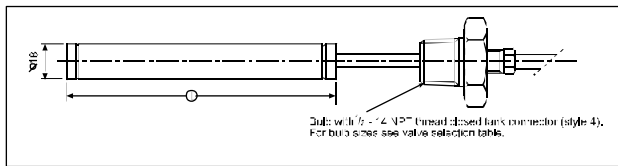

Note:
Never subject temperature bulb to temperatures in excess of 11°C above maximum range temperature. E.g. for range 24 to 57°C the maximum bulb temperature not to exceed 68°C.

Note:
To provide satisfactory operation, always install valve with bellows down and spring cage up. Capillary end of temperature bulb should always be higher than plugged-end of bulb, or if horizontal, the word TOP (marked on the surface of the sensor) should be at the top or uppermost surface of bulb.

Bulb Wells

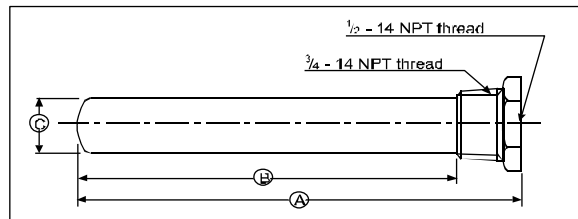

Part Number	Dimensions (mm)			Material	
	A	B	C	Conn ect	Tube
WEL17A-600	285	265	21	Steel	Copper
WEL17A-601	240	220	21	Steel	Copper
WEL18A-602	110	90	21	Steel	Brass

Renewal KITS

Each KIT contains parts as indicated in the table below. The complete KIT must be ordered that contains part required.		Disc cup	Valve disc	Plunger disc	Seat guide	Disc stud	Valve stem	Valve disc holder	Extention sleeve	Valve seat	Diaphragms	Gasket	Valve seat wrench	Screw	Seal ring
V47AA	STT002N600R	1	1	-	1	1	1	-	-	1	4	1	1	-	1
V47AB	STT003N600R	1	1	-	1	1	1	-	-	1	4	1	1	-	1
V47AC	STT004N600R	1	1	-	1	1	1	-	-	1	4	1	1	-	1

Dimensions (mm)

Angled type

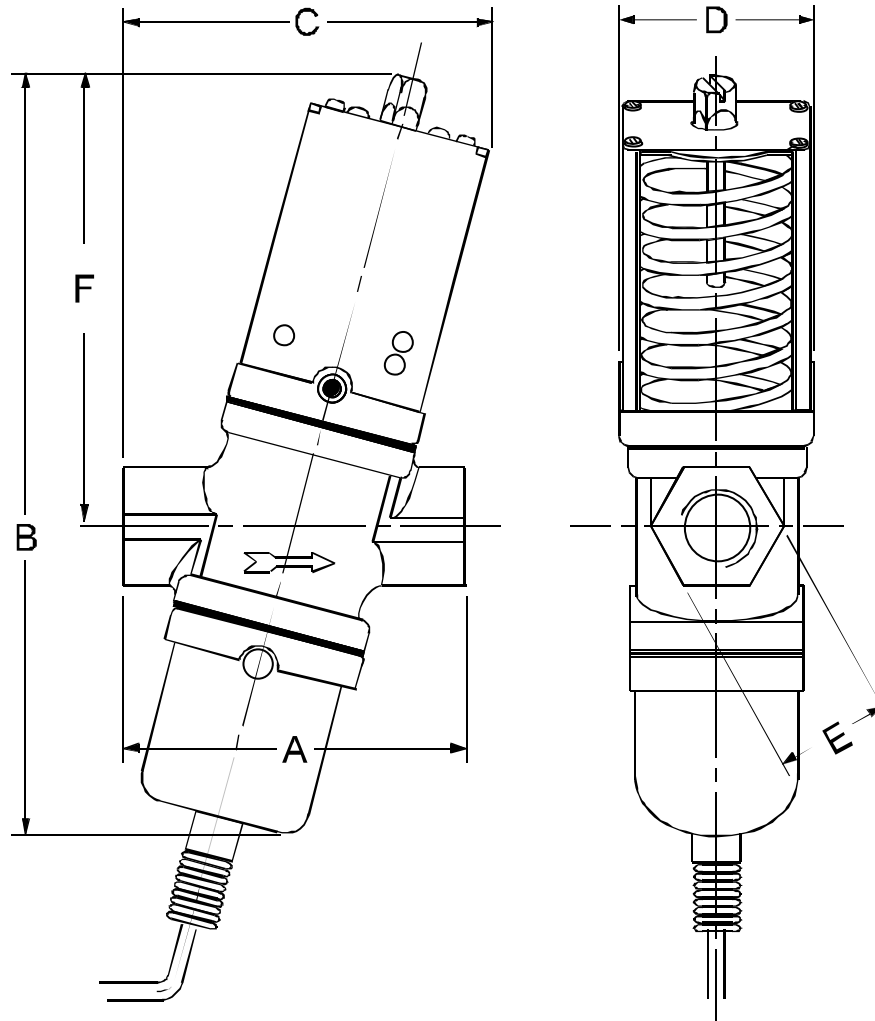

Commercial Types

Valve type	Valve size	Dimensions in mm					
		A	B	C	D	E	F
V47AA	3/8"	69	153	66	43	18	89
V47AB	1/2"	80	170	86	51	27	100
V47AC	3/4"	91	183	95	55	36	110

Dimensions (mm)

Straight type

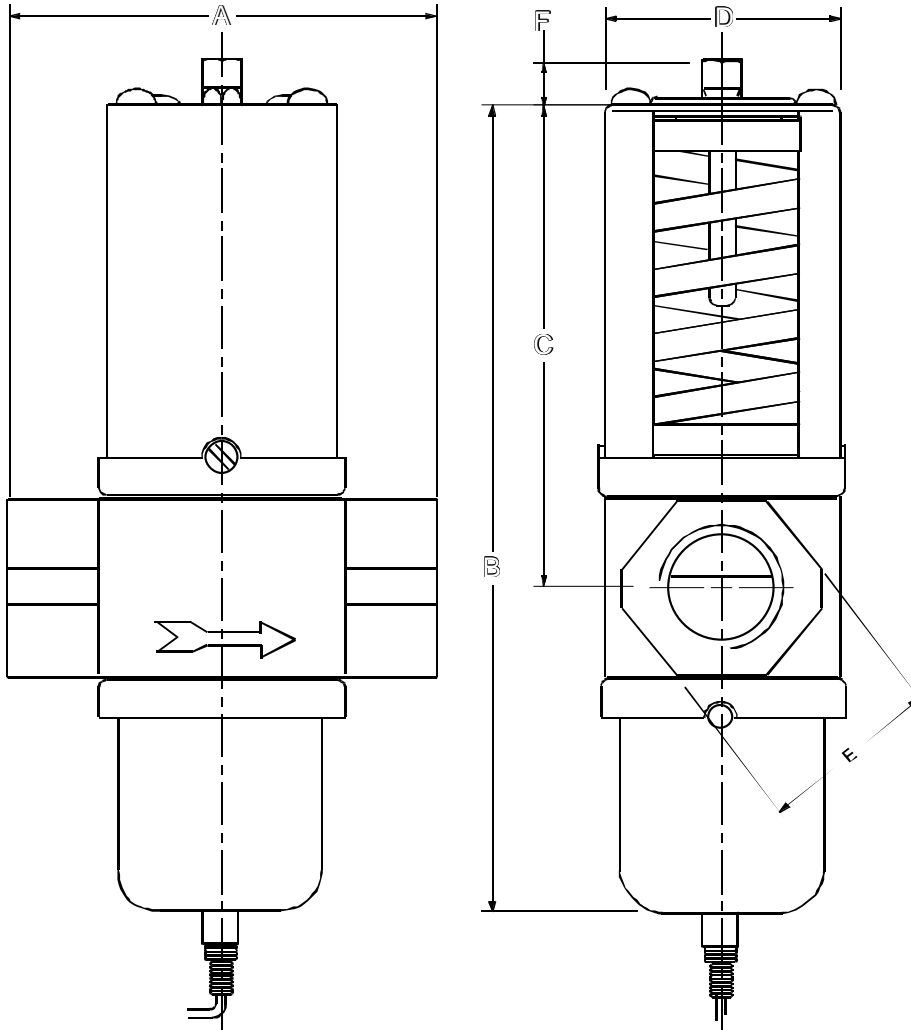

Commercial Types

Valve type	Valve size	Dimensions in mm.					
		A	B	C	D	E	F
V47AD	1"	124	233	139	72	50	13
V47AE	1 1/4"	125	243	145	72	58	13

Dimensions (mm)

Flange type

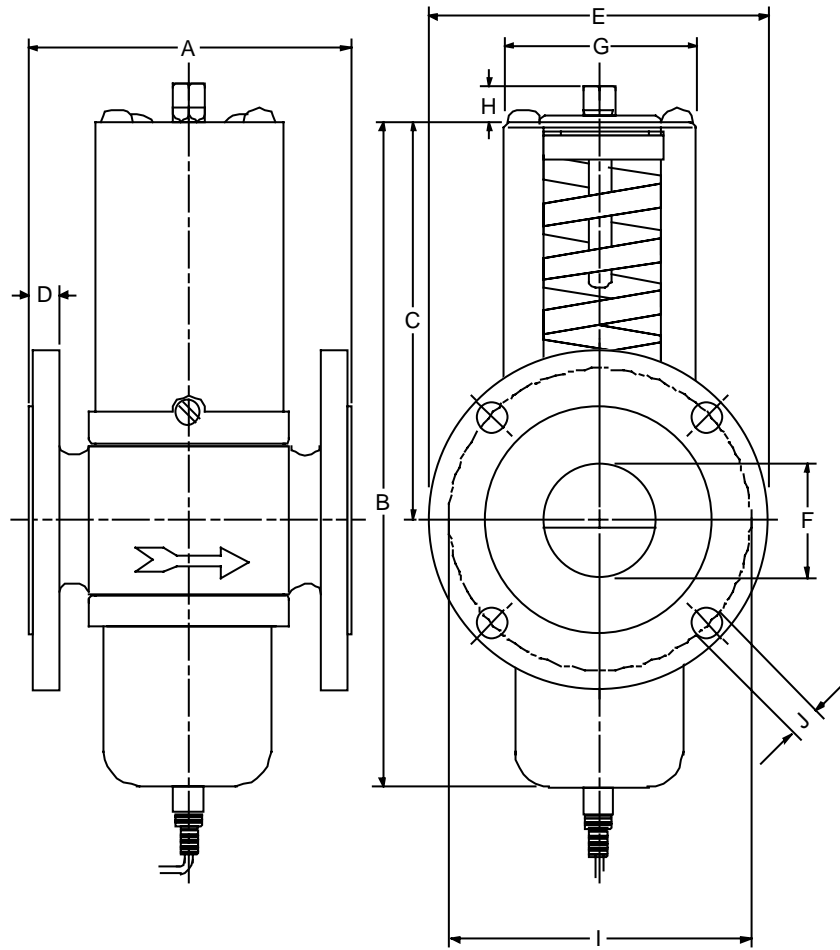

Commercial Types

Valve type	Valve size	Dimensions in mm.									
		A	B	C	D	E	F	G	H	I	J
V47AR	1 1/2"	137	244	144	18	150	47	67	13	110	18

Valve selection table

Commercial types

Item	Size inch	Range °C	Bulb Size mm	Max. Bulb Temp. °C	Connection body	Replacements		Weight single pack kg.	Bulb Well Oder separately
						renewal kit	diaphragm kit		
V47AA-9161	3/8	46/82	ø18 x 83	93	ISO 228 - G3/8	STT002N600R		1,40	WEL18A-602
V47AB-9160	1/2	24/57	ø18 x 83	68	ISO 228 - G1/2	STT003N600R	KIT016N601 (100)	2,00	WEL18A-602
V47AC-9160	3/4	24/57	ø18 x 83	68	ISO 228 - G3/4	STT004N600R		2,60	WEL18A-602
V47AD-9160	1	24/57	ø18 x 152	68	ISO 7 - Rc 1			4,50	WEL17A-601
V47AD-9161	1	46/82	ø18 x 152	93	ISO 7 - Rc 1			4,50	WEL17A-601
V47AE-9160	1 1/4	24/57	ø18 x 152	68	ISO 7 - Rc 1 1/4			5,50	WEL17A-601
V47AE-9161	1 1/4	46/82	ø18 x 152	93	ISO 7 - Rc 1 1/4			5,50	WEL17A-601
V47AR-9160	1 1/2	24/57	ø18 x 152	68	Flange 11/2 DIN2533			8,00	WEL17A-601
V47AR-9161	1 1/2	46/82	ø18 x 152	93	Flange 11/2 DIN2533			8,00	WEL17A-601

Specifications

Commercial

	Size	3/8" - 3/4"	1" - 1 1/4"	1 1/2"
Max. water supply press. (bar)		10	10	10
Max. water supply temp.		90 °C	90 °C	90 °C
Min. water supply temp.*		-20 °C	-20 °C	-20 °C
Valve body style	angled	x		
	straight		x	x
Pipe connection**	thread ISO 228	x		
	thread ISO 7 - Rc		x	
	flange DIN 2533			x
Capillary length (m)		1.8 plain	1.8 armored	1.8 armored
Material body		hot forged brass	cast iron***	cast iron***
disc stud/disc cup		brass	brass	brass
seat		alum. bronze	alum. bronze	alum. bronze
diaphragms		BUNA-N	BUNA-N	BUNA-N
bulb		copper	copper	copper
Closed tank connector		brass	brass	brass
stem/extension sleeve		brass	brass	brass
disc		BUNA-N	BUNA-N	BUNA-N

* Care should be taken the valve does not freeze up.

** Thread ISO 7 - Rc = DIN2999-RC thread/ISO 228 = DIN259-Rp thread

*** Cast iron bodies are executed with rust resisting finish

The performance specifications are nominal and conform to acceptable industry standards. For application at conditions beyond these specifications, consult the local Johnson Controls office. Johnson Controls, Inc. shall not be liable for damages resulting from misapplication or misuse of its products.



Johnson Controls International, Inc.

Headquarters: Milwaukee, Wisconsin, USA

European Customer Service Center: Westendhof 3, D-45143 Essen, Germany

European Factories: Essen (Germany), Leeuwarden (The Netherlands) and Lomagna (Italy)

Branch Offices: Principal European Cities.

This document is subject to change

www.johnsoncontrols.com

Printed in Europe

