



techsystem

automatyka klimatyzacja wentylacja

▸ zapoznaj się z naszą ofertą

Series V48

3-way Pressure Actuated Modulating Valves

Introduction

These watervalves are especially designed for condensing units cooled either by atmospheric or forced draft cooling towers. They may be used on single, or multiple condenser hook-ups to the tower. The type V48 valve senses the compressor head pressure and allows cooling water to flow to the condenser, to by-pass the condenser, or to allow waterflow to both condenser and by-pass line in order to maintain correct refrigerant head pressure. A further advantage of this system is that the 3-way valve permits a continuous water flow to the tower so the tower can operate efficiently with a minimum of maintenance on nozzles and wetting surfaces. The valves can be used in non-corrosive refrigerant systems. Ammonia power elements and valves designed for salt-water applications are available. The valves have a quick opening characteristic.



Series V48
Pressure Actuated Three-way Valve

Feature and Benefits

<input type="checkbox"/> Pressure balanced design	The valve setpoint and performance are independent of liquid inlet pressure. Valve can withstand severe hydraulic shock-waves without damage.
<input type="checkbox"/> Free movement of all parts	Provides smooth pressure modulation.
<input type="checkbox"/> Easy manual flushing	Does not affect valve adjustment.
<input type="checkbox"/> High Kv values	Small dimensions with very high capacity
<input type="checkbox"/> Pressure actuated	Direct and fast response to pressure variations
<input type="checkbox"/> Can be used as mixing or diverting valve	Reduces stock. One type for different applications.

Note

All series V48 water regulating valves are designed for use only as operating devices. Where system closure, improper flow or loss of pressure due to valve failure can result in personal injury and/or loss of property, the user must add a separate safety device.

Description

A pressure-balanced design employing rubber sealing diaphragms correctly proportioned to the valve port area, balances valve against both gradual and sudden water pressure changes, and seals water away from range spring, guides, and sliding parts so these are not submerged in water where they would be subject to sedimentation and corrosion.

Adjustment

The pressure at which the valve starts to open (= opening point port 1 to port 2) can be adjusted by the adjusting screw located at the top of the range spring housing. Valves may be adjusted with standard service valve wrenches or screwdrivers. (Valves are not factory set at a certain value.)

Manual flushing

Valves may be manually flushed by lifting the lower spring guide with screwdrivers at two sides of the pressure plate to open valve. This does not affect valve adjustment.

Installation

At a certain (adjustable) pressure, port 1 to port 2 starts to open, while port 1 to port 3 starts to close. This so called "opening point" is adjustable with the screw on the top of the spring housing and results in an equal amount change in both condenser and by-pass settings.

Valve size selection

The valve size is determined by three data:

- The required maximum flow (quantity of liquid = Q) that must pass the valve (in m³/h).
- The maximum allowed pressure drop (= ΔP) across the valve (in bar).
- The head pressure rise (= HPR) which is the difference between the pressure where port 1 to port 2 starts to open and the condenser operating pressure.

Note

At a certain pressure port 1 to port 2 starts to open. If the pressure decreases, it will close again at a $\approx 0,5$ bar lower pressure than the pressure where it starts to open.

The valve size can be selected by the use of:

- the diagrams on pages 4 and 5.
- k_V factors and calculation formulae (see page 3). This can only be used when the allowed head pressure rise is ≥ 3 bar for 4/16, 4/20 and 6/20 bar range valves. At lower head pressure rises the diagram has to be used.

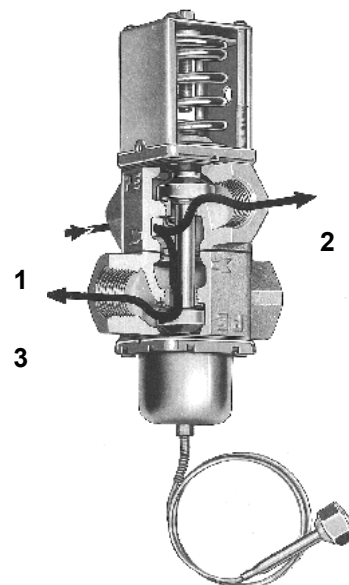
Cut-away section V48

- 1 From cooling system
- 2 To condenser
- 3 By-pass

Fig. 1

Valve size selection by the use of the diagrams pages 4 and 5

Q: The quantity of water (m³/h) is indicated on the left side of the upper diagram (= scale A).

Δ P: The curves for the pressure drop across the valve are indicated in the lower diagram (0,25 up to 1 bar, see scale C).

HPR: The head pressure rise above the valve opening point is indicated in the lower part of the diagrams on pages 4 and 5 (see scale B).

Note

See page 4 for the head pressure rise scales for valve range 4/16 bar and page 5 for range 4/20 and 6/20 bar valves.

Valve size:

The valve size can be read from the right side of the upper diagram.

Valve size selection example (see page 4):

Q = 5.1 m³/h
HPR = 3.2 bar
Δ P = 0.5 bar
Refrigerant = R22
Valve range = 4/16 bar

- Draw a horizontal line through the 5.1 m³/h point of scale A (see A).
- Draw a horizontal line through the 3.2 bar of scale B (see B). The intersection of this horizontal line with the delta P curve of 0.5 bar is used to draw a vertical line from this intersection point up to the horizontal line in scale A (see C).
- The intersection point of this vertical line with the horizontal line in scale A indicates the valve size. If the point falls on a size curve, this is the valve size needed. If it is between two sizes always take the largest valve size. In this example it is between size 3/4" and 1". The selected valve is 1".

Of course the same diagram can be used to read the pressure drop across a valve or to find the maximum capacity of a valve.

E.g. Pressure drop.

Q needed is 6 m³/h.
HPR is 2.5 bar.
The valve size available is 1".
What will be the pressure drop?

Solution:

- Draw a horizontal line through 6 m³/h (scale A) and determine the intersection of this line with the 1" valve curve.
- Draw a vertical line from this intersection point to the 2.5 bar HPR line.
- The found part is between the 0.5 and 0.75 bar pressure drop curves. Interpolate the point which gives 0.7 bar.

If this is acceptable the valve can be used.

E.g. Maximum flow.

Valve size is 1"
HPR = 3 bar
Maximum Δ P = 0.25 bar
What is maximum Q?

Solution:

- Draw a horizontal line at 3 bar HPR (scale B) till intersection with 0.25 bar delta P curve.
- Draw a vertical line from this intersection point to the 1" valve curve.
- Draw from this point a horizontal line to the water flow scale A.
You find 4.0 m³/h

Valve size selection by the use of the K_V factors and calculation formulae

For water:

The following K_V values can be used:

$$K_V = \frac{Q}{\sqrt{p}}$$

$$\Delta P = \left(\frac{Q}{K_V}\right)^2$$

$$Q = K_V \cdot \sqrt{p}$$

Valve size	K _V value
------------	----------------------

1/2"	2.3
3/4"	4.7
1"	8.0
1 1/4"	10.2
1 1/2"	16.5

Q = quantity of liquid (in m³/h)
Δ P = pressure drop across valve (in bar)
K_V = valve flow coefficient

The Kv factor is the quantity of 20°C water that will pass through the valve at one bar pressure drop (port 1 to port 2) and a valve opening which belongs by 3 bar (for high range valves) head pressure rise (HPR) above the valve opening point.

Diagram for selecting the valve size corresponding with information on page 2 and 3

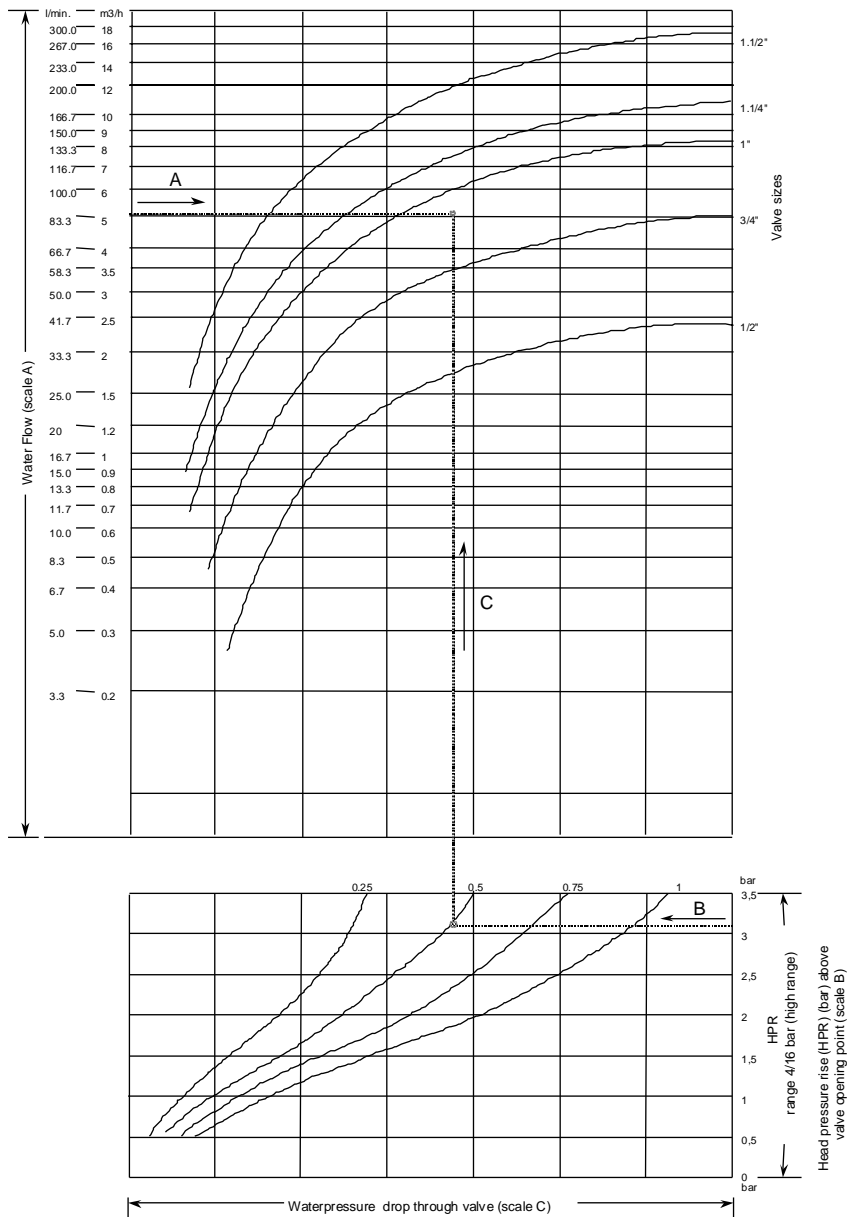

Note: 1 dm³/s = 3.6 m³/h = 15.8 U.S. gal./min. = 13.2 U.K. gal./min.
1 bar = 100 kPa = 0.1 MPa ≈ 1.02 kp/cm² = 1.02 at ≈ 14.5 psi.

Fig. 2a

Diagram for selecting the valve size corresponding with information on page 2 and 3

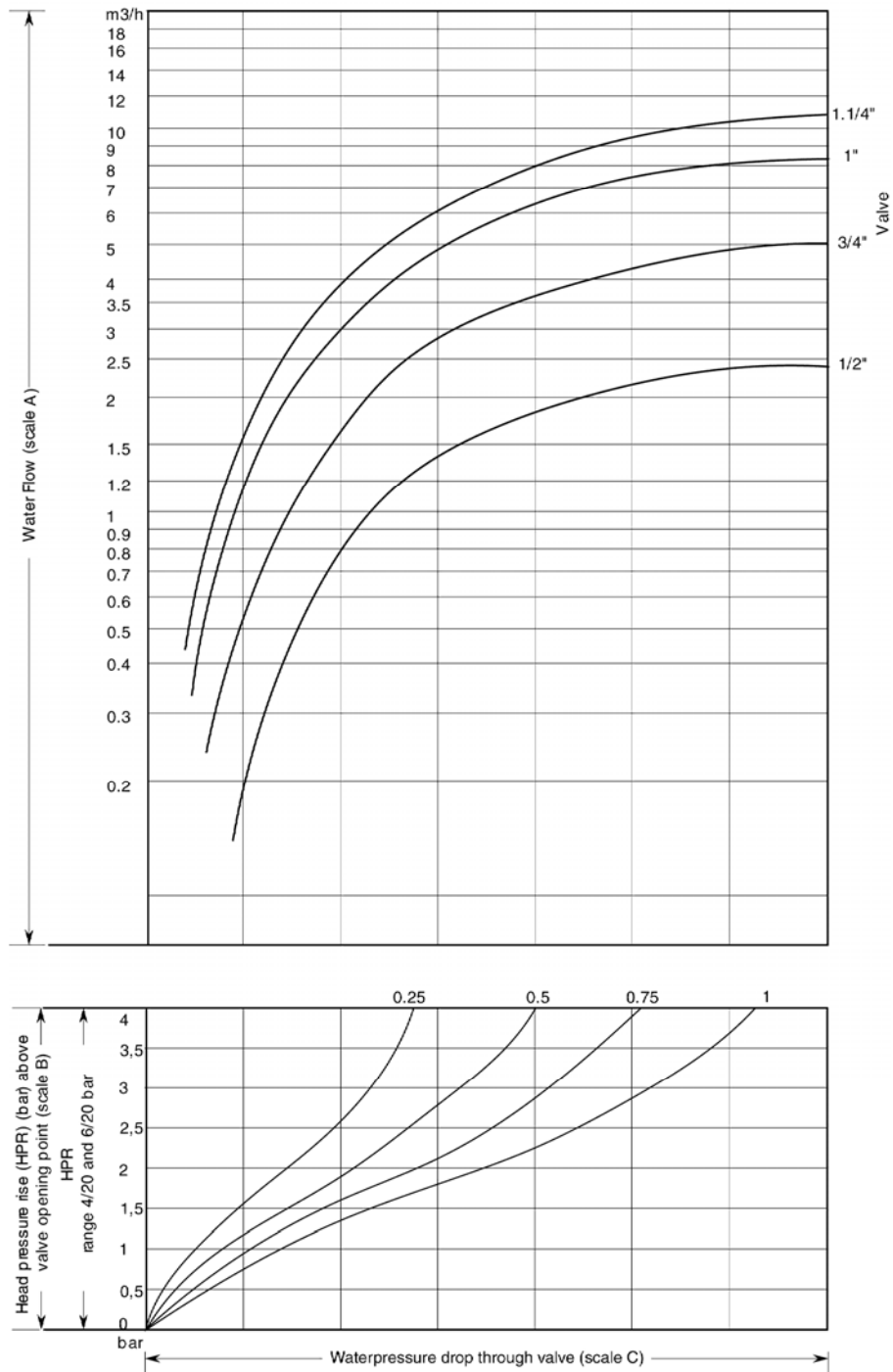

Fig.2b

Ammonia (NH₃) applications

For all larger valve types an ammonia element is available. These elements have style 15 pressure connection and consist of a stainless steel bellow in a steel cup (coated). The existing element can be replaced by this ammonia element. The pressure range does not change. For the high range valves the spring inside the power element has to be placed in the ammonia element. If low-pressure range is needed this spring can be removed. For low quantities you have to order the selected valve and separate ammonia replacement power element (see valve type selection table). For quantity orders a special valve type can be set up. Then please contact the JC sales office in your region.

Repair and replacement

Diaphragm kits can be ordered for all valves. Also the complete power element can be replaced. For a total revision of the valve a renewal kit can be ordered. For type numbers of replacement power elements, renewal kits and diaphragm kits see valve selection table.

If a replacement is ordered a "repair parts and service instruction" sheet will be included in which a step by step description is given to disassemble/assemble the valve.

Type number selection table and replacement parts

Commercial types

Item	Size inch	Range bar	Refrig. connec.	Capil. length	Connection thread	Weight single pack kg.	Quantity per box	Weight per box kg.
V48AB-9510	1/2	4 / 20	style 50	0.75	ISO 228 - G ¹ / ₂	2.3	1	2.3
V48AB-9600	1/2	4 / 16	style 13	0.75	ISO 228 - G ¹ / ₂	2.3	1	2.3
V48AC-9510	3/4	4 / 20	style 50	0.75	ISO 228 – G ³ / ₄	3.0	1	3.0
V48AC-9600	3/4	4 / 16	style 13	0.75	ISO 228 – G ³ / ₄	3.0	1	3.0
V48AD-9510	1	6 / 20	style 50	0.75	ISO 7 – Rc1	5.5	1	5.5
V48AD-9600	1	4 / 16	style 13	0.75	ISO 7 – Rc1	5.5	1	5.5
V48AE-9510	1 ¹ / ₄	6 / 20	style 50	0.75	ISO 7 – Rc1 ¹ / ₄	7.5	1	7.5
V48AE-9600	1 ¹ / ₄	4 / 16	style 13	0.75	ISO 7 – Rc1 ¹ / ₄	7.5	1	7.5
V48AF-9300	1 ¹ / ₂	6 / 14	style 5	-	ISO 7 – Rc1 ¹ / ₂	11.5	1	11.5

Item	Replacements		Ammonia element type
	power elem.	diaphragm kit	
V48AB-9510	Not available	KIT016N601 (100)	Not available
V48AB-9600	246-824R	KIT016N601 (100)	Not available
V48AB-9601	246-824R	KIT016N601 (100)	Not available
V48AC-9510	Not available		Not available
V48AC-9600	246-825R		Not available
V48AC-9601	246-825R		Not available
V48AD-9510	Not available		246-667R
V48AD-9600	246-925R		246-667R
V48AD-9601	246-925R		246-667R
V48AE-9510	Not available		246-667R
V48AE-9600	246-925R		246-667R
V48AE-9601	246-925R		246-667R
V48AF-9300	246-758R	KIT016N604 (25)	246-781R
V48AF-9301	246-671R	KIT016N604 (25)	246-781R

Sea-water types

Item	Size inch	Range bar	Refrig. connec.	Capil. length	Connection thread	Weight single pack kg.	Quantity per box	Weight per box kg.
V48BC-9600	3/4	4 / 16	13	0.75	ISO 228 – G ³ / ₄	3.0	1	3.0

Item	Replacements		Ammonia element type
	power elem.		
V48BC-9600	246-825R		Not available

Pressure connections

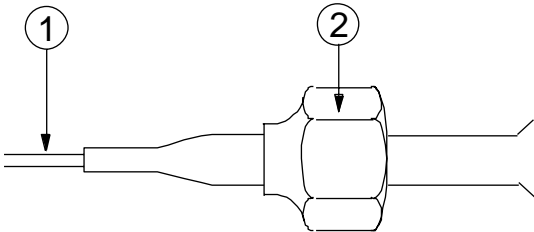

Fig. 3

Style 13 (excl. valve depressor)

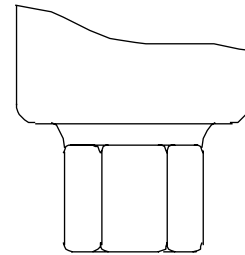

Fig. 5

Style 15 1/4-18NPT (female)

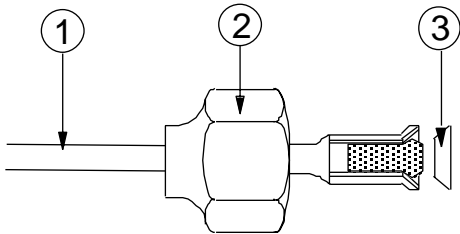

Fig. 4

Style 50 (incl. valve depressor mounted into machined flare)

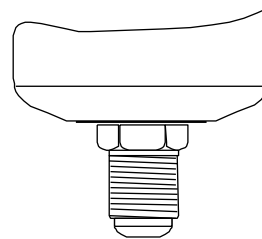

Fig. 6

Style 5 7/16-20 UNF

1. 75 cm capillary.
2. 7/16 - 20 UNF flare nut.
3. copper sealing

Dimensions (mm)

For valve type see specifications page 11

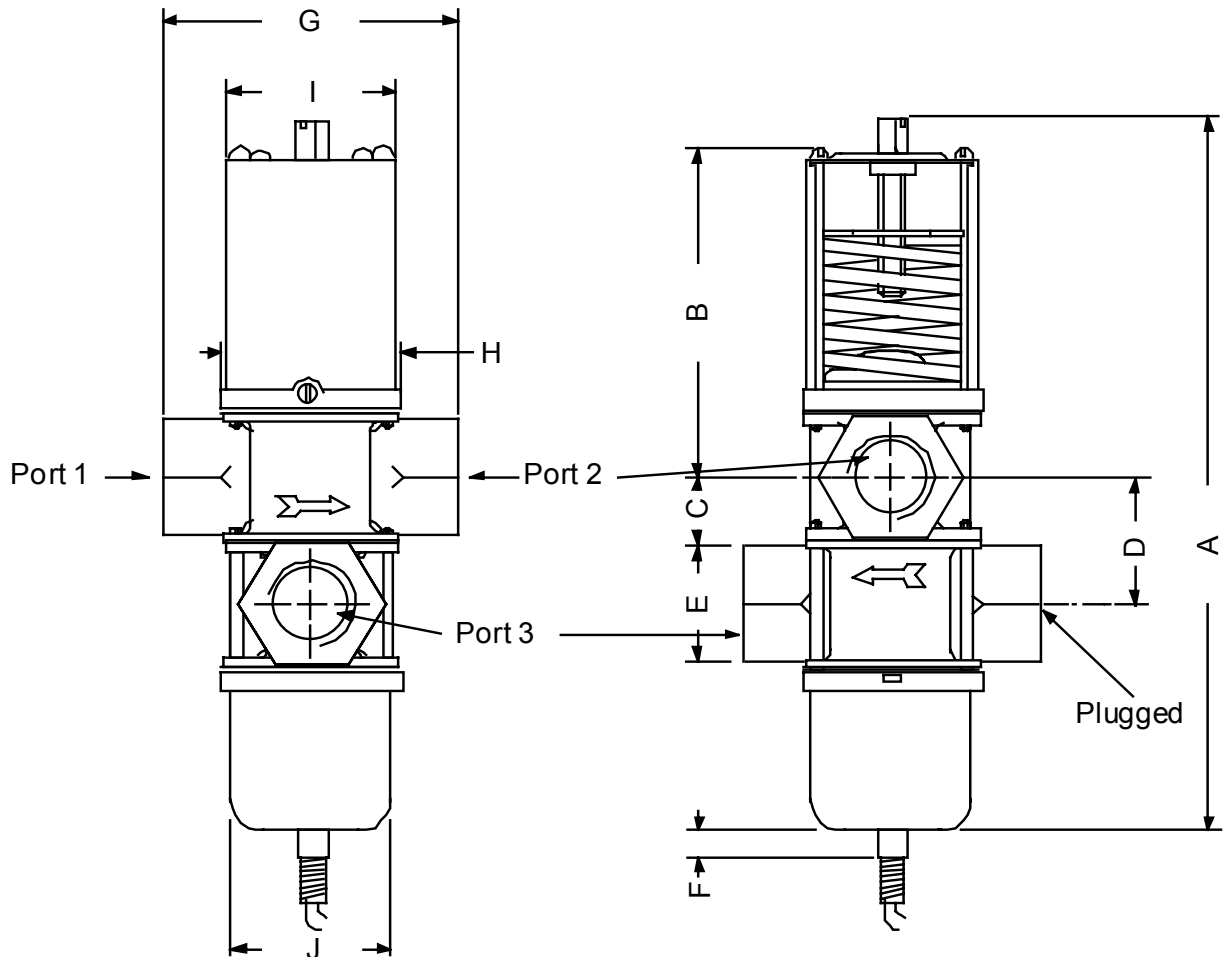

Commercial Types

Valve type	Valve size	A mm	B mm	C mm	D mm	E mm	F mm	G mm	H mm	I mm	J mm
V48AB	1/2"	192	91	19	41	30	8	82	52	48	52
V48AC	3/4"	208	100	23	45	36	8	88	56	52	56
V48AD	1"	287	142	25	51	50	8	124	71	67	72
V48AE	1 1/4"	296	141	31	61	58	8	127	71	67	71

Sea-water Types

V48BC	3/4"	203	97	22	45	35	9	95	55	52	55
-------	------	-----	----	----	----	----	---	----	----	----	----

Size 1/2" - 1 1/4"

Fig. 7

Dimensions (mm)

For valve type see specifications page 11

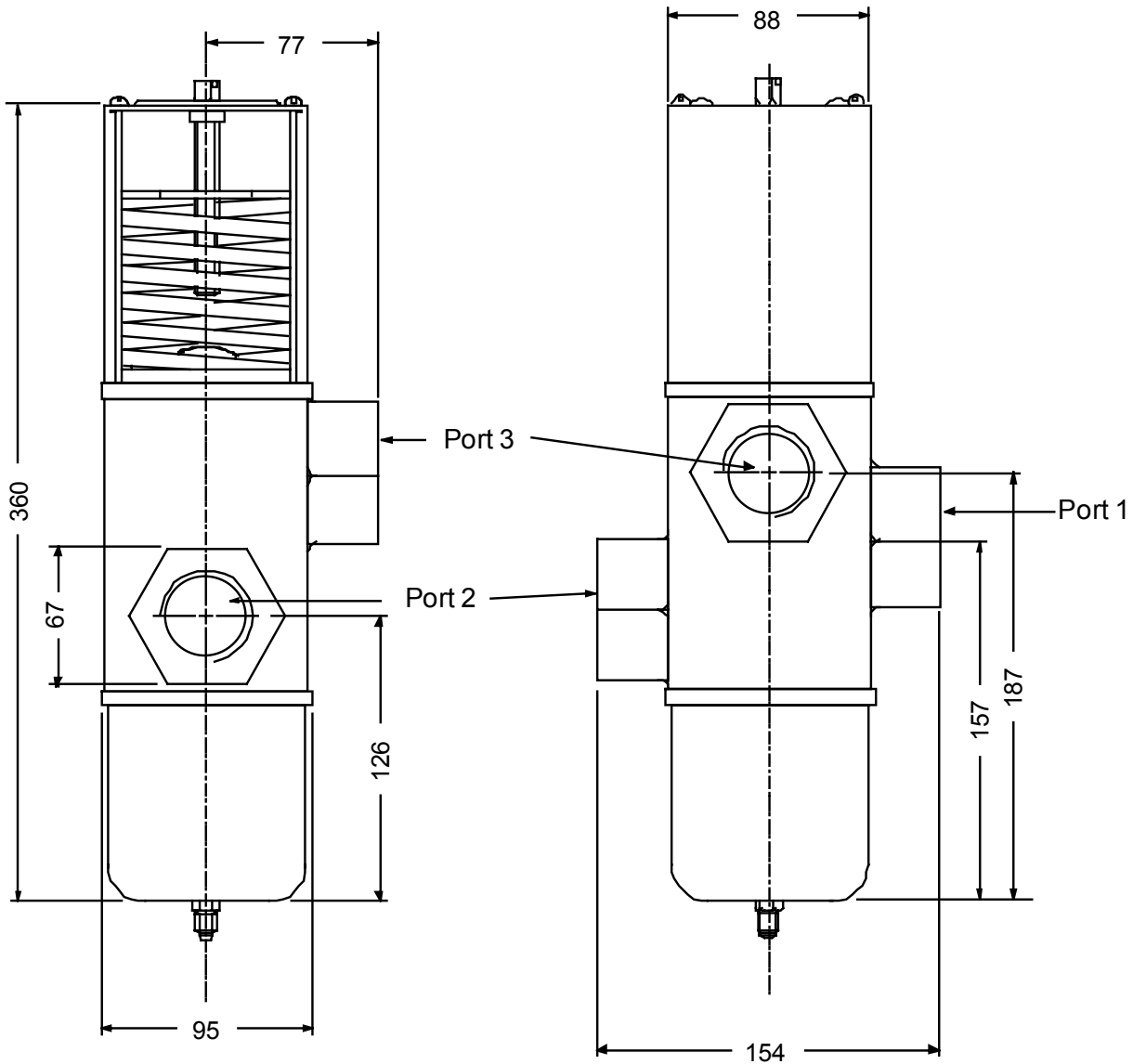

V48AF

Size 1 1/2"
Fig. 8

Specifications

	Commercial			Sea-water
	Size	1/2" - 3/4"	1" - 1 1/4"	1 1/2"
Operating range (bar)	4-16 4-20	4-16 6-20	6-14	4-16
Max. refriger. overrun press. (bar)	28	28	28	28
Max. water supply press. (bar)	10	10	10	10
Max. water supply temp.	90 °C	90 °C	90 °C	90 °C
Min. water supply temp. *	-20 °C	-20 °C	-20 °C	-20 °C
Valve hysteresis (bar)	~ 0.5	~ 0.5	~ 0.5	~ 0.5
Pipe ** thread ISO 228	x			x
connection thread ISO 7 - Rc		x	x	
Material body	brass	cast iron***	cast iron***	bronze
disc stud/disc cup	brass	brass	brass	monel
seat	alum. bronze	alum. bronze	alum. bronze	monel
diaphragms	BUNA-N	BUNA-N	BUNA-N	BUNA-N
bellows	ph. bronze	ph. bronze	monel	ph. bronze
stem/spacers	brass	brass	brass	monel
disc	BUNA-N	BUNA-N	DURONZE	BUNA-N
Pressure connection style	See selection table.			
Capillary length	See selection table.			
Ammonia element style 15 press. connection	Stainless steel bellow in steel cup.			
Shipping weights	See valve selection table.			

* Care should be taken the valve does not freeze up.

** Thread ISO 7 - Rc = DIN2999-RC thread / ISO 228 = DIN259-Rp thread

*** Cast iron bodies are executed with rust resisting finish

The performance specifications are nominal and conform to acceptable industry standards. For application at conditions beyond these specifications, consult the local Johnson Controls office. Johnson Controls, Inc. shall not be liable for damages resulting from misapplication or misuse of its products.



Johnson Controls International, Inc.

Headquarters: Milwaukee, WI, USA
 European Headquarters: Brussels, Belgium
 European Factories: Lomagna (Italy), Leeuwarden (The Netherlands) and Essen (Germany)
 Branch Offices: Principal European Cities.

This document is subject to change

www.johnsoncontrols.com
 Printed in Europe